



A5

Audi A5 Coupe | A5 Cabriolet | S5 Coupe | S5 Cabriolet

Audi Truth in Engineering 





Reflecting on what matters most to us.

In so many ways, it's really all connected. How an Audi vehicle is engineered and designed isn't simply a matter of physics or architecture, it's a systematic compilation of disparate disciplines and ideas, forged into something iconic, sophisticated and powerful. What you feel behind the wheel is, in so many ways, a product of the knowledge and imagination of human history. The principles of Newtonian laws, sure—but also the grace of choreography, time-honored artisanal craftsmanship and the connectivity of modern life. The end result of these inspirations is your Audi—a thing meaningful, intuitive and strong. We employ the sum of our skills and understanding to reflect something that goes deeper than our machines.

The rewards of being a risk taker.





A5 | S5

A dual threat in inspiring performance and passionate design, the A5 and S5 combine dynamic handling and muscular styling to elevate your driving experience.

Nothing captures the imagination like an automobile that turns heads. A statement that is even more impactful when you consider that every double-take the Audi A5 gets is a testament to the adventurous spirit and bold sensibilities of both Audi designers and drivers alike. It's why there is such a strong response to the sophisticated lines that sweep across the A5, as well as to the seductive punch of its acceleration. Everything we build into the A5, even the way we hide the B-pillar, is meant to give it a sense of movement, even when it is standing still. Heads turn because we pay attention to every detail, from the precision handling to the striking headlights with LED daytime running lights, which seem to stare back at attentive onlookers. Available in Coupe and Cabriolet, there is an A5, and an exhilarating Audi S5, crafted to provoke emotion, and maybe even a little envy, in every person who looks as you drive by.





The background is a bright, minimalist white interior. Light rays, represented by solid and dotted lines with small arrowheads, stream from a window on the left towards the right. On the right side, there is a technical drawing of a car's profile, showing a solid black line and a dotted line. The drawing includes horizontal and vertical reference lines, with labels $\frac{1}{3}$ and $\frac{2}{3}$ indicating proportions. The overall aesthetic is clean, modern, and technical.

The irrepressible actuality of light.

Light is a wave and an energy. It's also a feeling. And an inspiration. Light is a physical manifestation and a spiritual metaphor. For Audi designers, light represents the soul of automotive design. We use it to give lines context, add a shimmering allure, or give shapes a visual texture or depth. In the sun or on a city street, the vehicle becomes luminescent, a seductive, ever-shifting configuration of energy itself, expressed in the brilliance of each design line.



Signature LED daytime running lights, iconic Singleframe grille and a wide, muscular stance give the A5 a distinctive look that can't be ignored.

A moving performance, even at a standstill.

It may be, as has been suggested, that the Audi A5 creates an irresistible pull. Then again, magnetic design is like that. Of course, we know what draws people in. The unmistakable look, to start, but the power too. LED daytime running lights introduce inviting illumination, and the tapered Singleframe® grille adds a bold sense of daring and an iconic look to the front fascia. But one gathers the possibility of more, such as the power distributed by the impressive 2.0-liter turbocharged TFSI® engine and optimized by the quattro® all-wheel drive system. The details tell the story—sharpened design lines streamline the body, continually pushing the envelope of style while embracing the spirit of our Audi Sport® heritage. In short, the more we tried to thrill onlookers, the greater thrill we experienced ourselves.



2016 Audi A5 2.0T Coupe Premium Plus shown in Daytona Gray pearl with available equipment.

A brilliant display of design and delight.



2016 Audi A5 2.0T Coupe Premium Plus shown in Florett Silver metallic with available equipment.



Integrated rear spoiler

An example of thoughtful integration, the integrated rear spoiler adds to the vehicle's visual appeal while delivering a true performance benefit. At higher speeds, it provides additional downforce, helping to enhance the performance of the A5.

Everywhere you look, the Audi A5 inspires with memorable design and impressive features. It starts with the bold design lines that run from the corner of the headlights to the rear of the vehicle, and finishes with details like an artfully integrated rear spoiler and distinctive LED lighting. It's a tribute to everything Audi design stands for.



Xenon plus headlights

Producing a large light arc with a color similar to daylight's, xenon plus headlights not only help with the early recognition of obstacles in front of the vehicle, but also add a touch of brilliance to any nighttime excursion.

The intuitive layout of the cockpit is plain to see, with every dial and switch within easy reach.



2016 Audi A5 2.0T Coupe Premium Plus shown with Titanium Gray leather and available equipment.

A bold tribute to maximum control.

Thanks to an interior design that puts as much emphasis on functionality as it does on form, every control you need is right at your fingertips, intuitively placed to help establish an ease of operation while you navigate any commute. Our driver-centric cockpit is more than just a design imperative, it is our way to help ensure that you're navigating the vehicle's technology with the same precision that our vehicles perform with on the road.¹



Three-spoke multifunction steering wheel

Get ready to own the road with the three-spoke multifunction steering wheel. It features available shift paddles for a truly engaging driving experience and offers a way to access your MMI® system while keeping both hands on the wheel.

Decorative interior inlays

With aluminum inlays or your choice of available beautiful wood or Piano Black inlays, you will find unparalleled craftsmanship and attention to design throughout the interior. We use only the finest materials inside the cabin to accentuate luxury and sport.

Our obsession with design goes beyond sheet metal.

The finest materials pepper the interior of every Audi A5. There may be more modest ways to design a vehicle's interior, but ours are intended to stimulate more than just your sight. You'll see, feel and smell the distinctive elements inside the A5. Whether it's the finely stitched leather-wrapped multifunction steering wheel in your hands, or the scent of our finely crafted leathers that greets you when you climb into the cockpit, you'll find exactly what you've come to expect from Audi: sleek, fluid and substantively composed interiors that solidify the connection between you and your vehicle.



Split folding rear seatbacks

With 12.2 cu ft of cargo space in the A5 Coupe and 10.2 cu ft of cargo space in the A5 Cabriolet with the rear seatbacks in the up position, the A5 is a capable carrier. The Cabriolet has split folding 50/50 rear seatbacks, and the Coupe features a pass-through in the split folding 60/40 rear seatbacks. It's proof that a sports car can still be versatile.

Panoramic sunroof

Another enhancement to your drive in the A5 Coupe is the standard panoramic sunroof with tilt functionality. A nearly unimpeded view of the sky gives the feeling of infinite head room. If you don't want to fully engage with the environment, the retractable shade feature is there too. So let the sun drench the interior of your A5 as you enjoy a carefree driving experience.



Three-zone automatic climate control

Here's a comforting thought—personal attention has been taken to new heights in the A5. With three-zone automatic climate control, almost every person in the vehicle has the ability to dial in their ideal temperature, giving you and your passengers the climate you want regardless of what the weather is like outside.

Front sport seats

The available front sport seats feature bolsters in all the right places, including the upper shoulder, sides and seat base, and have extendable thigh supports. These front sport seats help provide a proper seating position and help hold you comfortably in place in both the bends and the straightaways.



2016 Audi A5 2.0T Coupe Premium Plus shown with Titanium Gray leather and available equipment.

Being open to possibilities has its perks.

It's style that includes stars, but has nothing to do with Hollywood. It's outside, but not obsessed with waterproof hiking boots. It's the world seen and felt with the top down in your Audi A5 Cabriolet. Day or night, with wind gliding past you, discover a thrilling connection to your environment—while still being plugged into signature automobile technology. You can even stretch your top-down driving season with an available head-level heating system that helps ensure your comfort even when the temperature doesn't match your mood. The A5 Cabriolet takes design, precision and a retractable roof to turn the outside into something that's very much in.



Retractable acoustic folding soft top

The top of the A5 Cabriolet invites you to take advantage of clear skies for as long as the sun is out. If clouds do come, it takes approximately 17 seconds for the top to fully deploy (even at speeds up to 31 mph). When the top is up, it also provides a great acoustic environment designed with both sound-deadening and insulation properties.

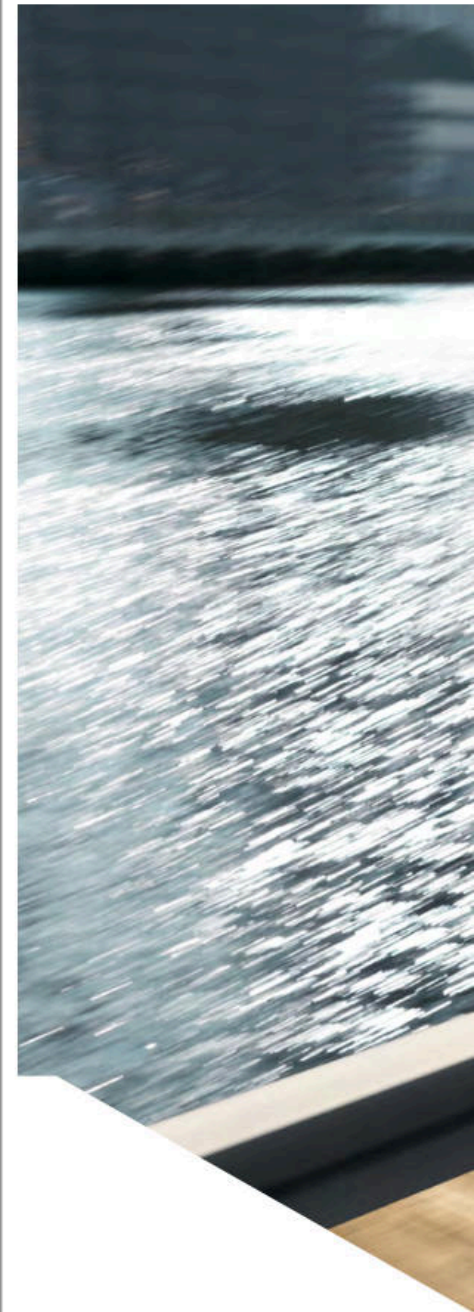



With clean lines and more than enough presence, the A5 Cabriolet encourages you to own the road, rain or shine.

Experience a plush refuge in almost any climate.

We've got you covered, even with the top down. The available perforated Milano leather ventilated and heated front comfort seats create a tranquil commute no matter what the weather brings. From heat-reducing pigments in the leather to an aerodynamic windblocker that helps the air flow by when you open up the drive, we've thought of nearly everything to help ensure your comfort. Just in case you've forgotten your sunscreen, you can easily bring the roof back up, further proof that you hold a wide range of power.



Ventilated and heated front seats

Some added comforts for the top-down drive along the coast are the available heated and ventilated front comfort seats. You can get a little extra touch of warmth from the available head-level heating system vents that blow warm air directly onto your neck and shoulders.

Thermocool™

The leather seating surfaces of our Audi A5 Cabriolet front seats are designed with special Thermocool™ heat-reducing pigments that, even in direct sunlight, help reduce surface temperatures where it is needed, compared to untreated leathers. It's just another way we prove our commitment to your comfort.



2016 Audi A5 2.0T Cabriolet Premium Plus shown with perforated Velvet Beige Milano leather and available equipment.

A showcase of our driving desire for superior engineering.

Producing more power from smaller engines has been a “right-sizing” philosophy of ours for quite some time, something you’ll soon realize when you experience the dynamic performance of the turbocharged 2.0-liter TFSI® engine. And with two advanced transmission options and the road-gripping capability of quattro® all-wheel drive, it will feel as good as its engineering suggests.

POWER
↓
↓

2.0 TFSI® four-cylinder engine

This 2.0-liter turbocharged DOHC engine produces 220 horsepower and 258 lb-ft of torque, and combines the valvelift system, direct injection and turbocharging technologies for great power and overall performance.

APPLICATION
↓
↓

Six-speed manual transmission

For drivers who crave engaging and dynamic response, the Audi A5 Coupe presents an available six-speed manual gearbox that delivers power with vintage Audi finesse. Its short throw and precise ratios add a contemporary element for confident performance on the road.

Eight-speed Tiptronic® automatic transmission

As the perfect compromise between a dedicated manual and an automatic gearbox, the eight-speed Tiptronic® automatic transmission available in the A5 offers eight optimized, carefully chosen gear ratios. Selected automatically or via its console-mounted shifter or steering wheel with available shift paddles, precise shifts are delivered without sacrificing the smooth action of the Tiptronic® automatic. A high final drive ratio allows optimization of lower gears, yet the transmission’s upper range emphasizes cruising at highway speeds.

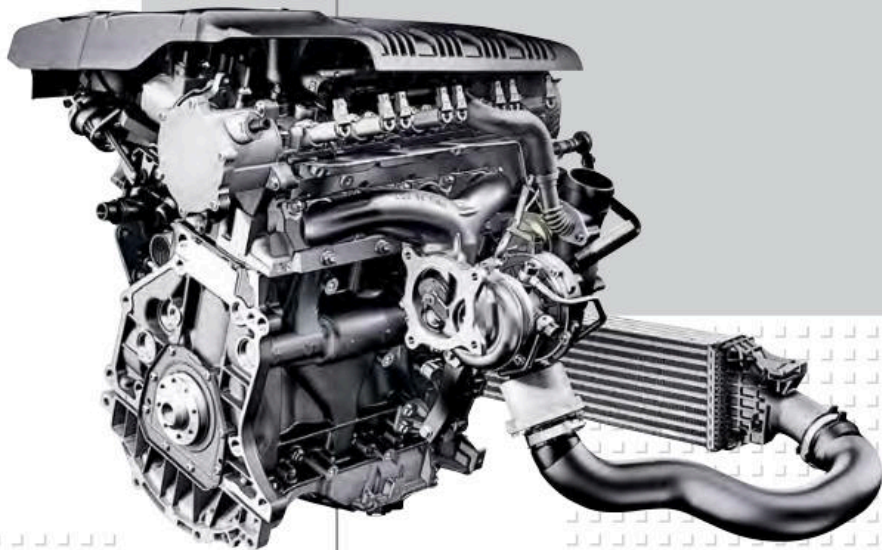

quattro® all-wheel drive

There is a reason quattro® has been known as the all-wheel-drive standard since its inception—it has helped us to win races all over the world, and lots of them. But it's not just a performance enhancing technology, it has also become the proven foul-weather friend! Under normal driving conditions, the center differential splits torque at a ratio of 40:60, front to rear (maximizing performance on dry roads), but, as conditions change and become more challenging, the ratio is optimized to help maximize grip. This translates to traction and a more confident driving experience.

**Audi drive select**

At Audi, we believe you should be the ultimate master of your road-going domain. That's why we created the available Audi drive select system. It gives you the ability to adjust the vehicle's steering, throttle response and transmission shift characteristics with the utmost of ease (Audi S5 models add suspension and sport differential as well as dynamic steering control if equipped). And with four modes to choose from, when almost any kind of road comes into question, Audi drive select will let you answer.

- ▶ **Comfort mode**
Perfect for those long highway stretches, this setting adds optimized steering and a closer shift pattern to help provide a more relaxed drive.
- ▶ **Dynamic mode**
Tighter steering and a more responsive throttle give this setting an aggressive feel and focused performance.
- ▶ **Auto mode**
The best of both worlds, dialed to automatically adjust settings for a seamless combination of comfort and responsiveness based on your driving style and road conditions.
- ▶ **Individual mode**
Take the turn your way—this mode allows you to adjust the steering, throttle and transmission upshifts to your style.



Embodying the essence of performance.

For Audi engineers, power delivery is a primal thing. Sure, we sweat over balance, we obsess over precise handling, we shave off ounces and even pounds where we can to produce an improved response, quick acceleration and dynamic cornering, but in our hearts, at Audi, we want performance that inspires confidence. We have a heritage of racing success—and that helps us make the case—but it's a truer testament of engineering to make it work on the street, the highway, the commute. To engineer those moments where the rest of the vehicle seems to disappear and you are well into the moment of exhilaration, the light turns green, you accelerate. Performance—sculpted, engineered, Audi performance—makes its own case for the greatness of your vehicle.¹



S5

Providing a visual aid to this vehicle's stunning performance are a front bumper and distinct Singleframe® grille specific to the Audi S model.



2016 Audi S5 Coupe Prestige shown in Ibis White with available equipment.

Establishing a Bavarian purity law for performance.

While the Audi A5 may be everything the devotee of the authentic coupe requires, sometimes even a purist yearns for a truly distinct brew of engineering. Taking a page from a 15th-century purity law regulating the production of German beer, we only used the finest performance ingredients when creating the Audi S5. A supercharged 3.0-liter TFSI® V6 engine sits comfortably under the hood of the S5, producing 333 horsepower and an exhilarating 325 lb-ft of torque, to propel the S5 Coupe to 60 mph in just 4.9 seconds.¹ Experience the heart and soul of Audi performance cars through the sport-tuned suspension that is ready for the street or the track. While others may not take their performance standards this seriously, we wanted to make sure the thrill you feel behind the wheel was as pure as possible.²

> 3.0-liter supercharged TFSI® V6 engine

> 333 hp/325 lb-ft torque

> 0-60 mph in 4.9 seconds (Coupe)¹

> 0-60 mph in 5.3 seconds (Cabriolet)¹

> Top track speed of 155 mph²



Sport differential

To help ensure high cornering stability, the optional sport differential uses torque vectoring, and then adds to that by mechanically applying additional torque to the outside rear cornering wheel. Through an electrohydraulic multiplate clutch pack and gear set, the outside rear cornering wheel's speed is increased by as much as 10% compared to the drive shaft's.

S5



While the Audi S5 is all about performance, craftsmanship and comfort are just as apparent in every interior element.





Sport-contoured design

Even on the inside, this vehicle's ultimate purpose is impossible to ignore. Just consider the sport-contoured seating, ample bolsters and carefully integrated head restraints. And just in case you miss all that, the S5 signifier emblazoned on the front seats and available Alcantara® or Fine Nappa leather seating surfaces will surely make this vehicle's intentions clear.

A union of details that define a muscular look.

In here, the powerful and the distinctive combine to give a memorable performance. Sport-contoured seating helps hold you through the turns while signifying our dedication to craftsmanship. From there, the performance gets even more intriguing with features that help sharpen your control, like a flat-bottom sport steering wheel with shift paddles in the S5 Cabriolet, or without them in the manual transmission S5 Coupe, and the advanced precision of the available dynamic steering. Taken as a whole, this is an interior that isn't shy about its ultimate purpose.



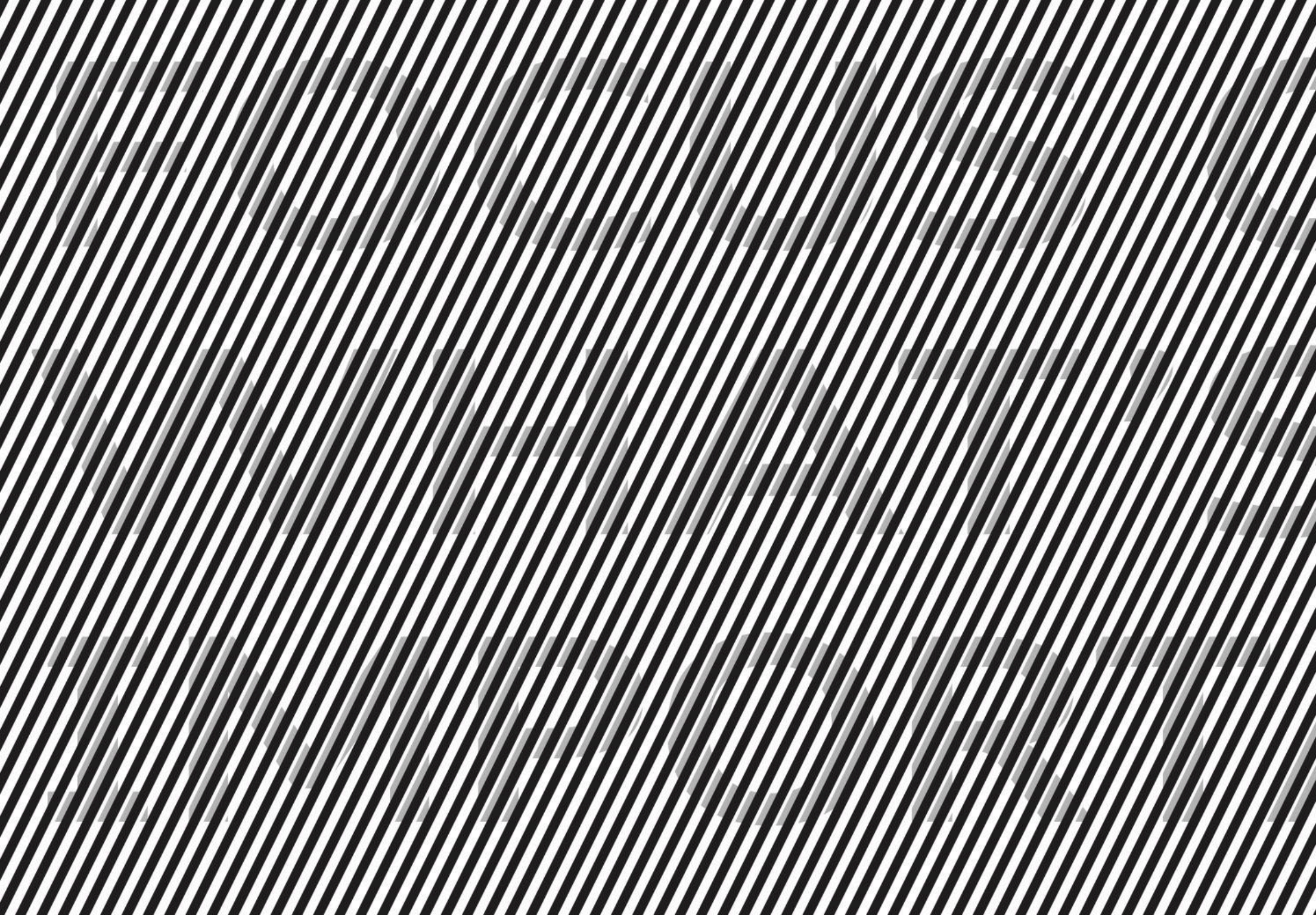



You might be missing something, but we won't.

With everything that's out there, we thought it was time to focus on what you really need to see—like that car in your blind spot, for example. Fortunately, there's a full suite of available Audi technologies that help take into account other vehicles as well as yours via intelligent driver assistance systems. These can help you focus on what's most important—the road.

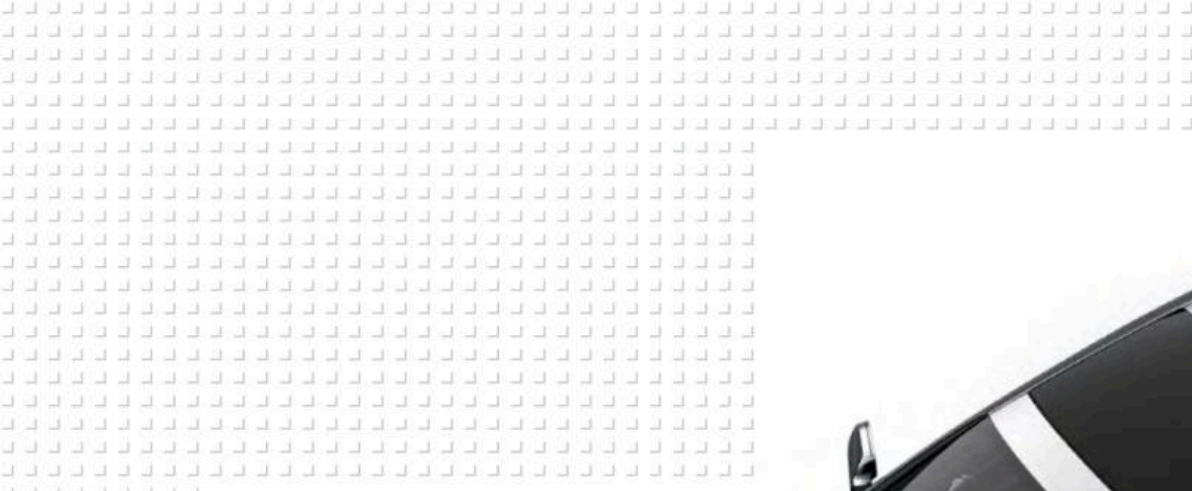

-  Radar sensors
-  Ultrasonic sensors
-  Camera

Image featured is a pictorial and not an exact representation of the trajectory of the camera and sensors.

Senses working overtime.

There's only so much our nervous system can process at one time. Too much, and you'll feel the debilitating effects of sensory overload. We set out to combat this effect with driver assistance features designed to help lighten the sensory load. Whether it's available advanced technologies like Audi adaptive cruise control, which uses long-range radar to help read the traffic conditions and adjust speed accordingly, or Audi side assist,¹ which utilizes radar sensors to help inform you of vehicles approaching from the side and rear, you'll find that we've developed them to work together to help keep you aware of your surroundings. It's just another way we like to say "We're looking out for you."

LANE AWARENESS
→
→

Audi side assist

The available Audi side assist uses radar sensors and two different optical warnings to help keep the driver informed about what is approaching from hard-to-see angles behind and to the side of the vehicle.¹

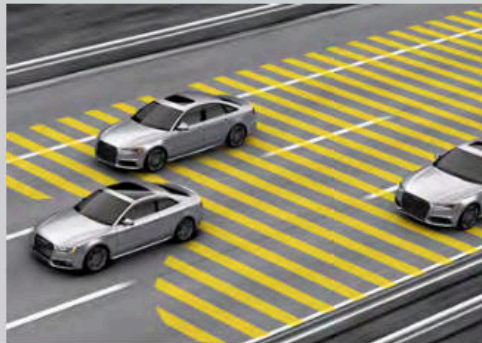

SEMI-AUTOMATION
→
→

Audi adaptive cruise control

Available on the Audi S5, Audi adaptive cruise control helps maintain a driver-selected distance from the vehicle in front by using a special long-range radar sensor. The system constantly measures the space between your vehicle and the vehicle ahead and helps manage it by automatically adjusting your speed. Once the road ahead is clear, the vehicle effortlessly resumes the previously preset speed.

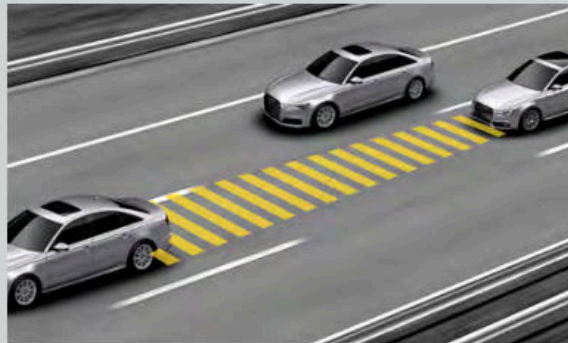

DRIVER AWARENESS
→
→

Parking system with rear view camera

Increasing awareness and helping to make parking an easier task, the available parking system features four acoustic sensors in the rear (in addition, front sensors are also available on the Audi A5 Coupe). For added benefit, the rear view camera, displayed on the MMI® screen, offers selectable guidelines for parking in parallel or perpendicular spaces.

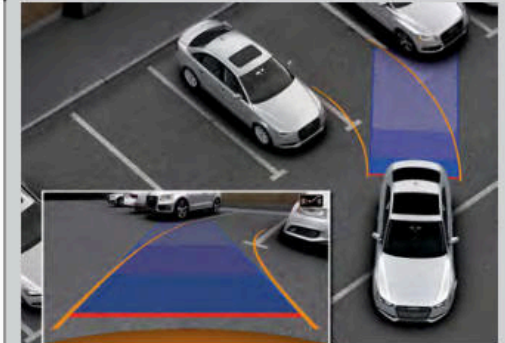

¹ The features discussed are not substitutes for attentive driving. Always check surrounding traffic, and use turn signals. Please see your owner's manual for further details and important limitations.

When the right materials strike a perfect chord.

At the heart of every great performance is an equally powerful instrument. Lightweight yet strong, a violin embodies many of the qualities that make up our core engineering philosophy. Whether it's the way we bind different metals together to help form a more rigid connection or the way we shape our design for functionality and performance or even the way our crumple zones give in the right places to help dissipate energy, the similarities are present for a reason. You can't expect to perform at the highest level without a solid foundation.

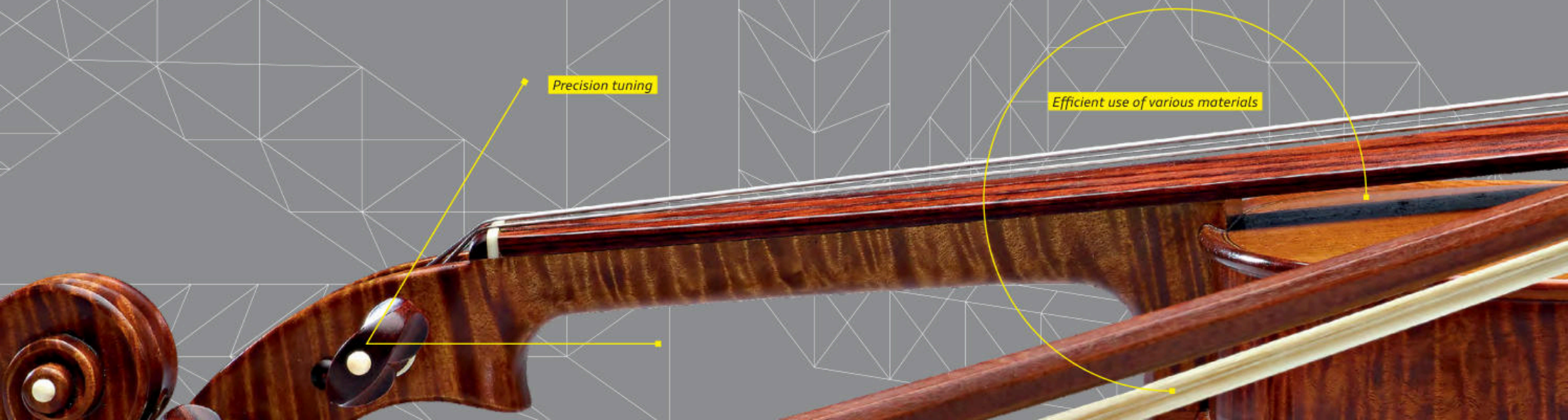

Precision tuning

Efficient use of various materials



Optimal tension

Structural balance

Enduring craftsmanship

A design that helps diminish an impact is no accident.

While we don't like to make light of potential risks on the road, our engineers were tasked with doing just that. Using materials that are both lightweight and unyielding, they came up with an innovative approach to both weight savings and strength. And while you may not think about weight savings when it comes to strength, we think they go hand in hand. Complementing the occupant safety cell is airbag technology designed to respond differently based on seat position, and specially constructed crumple zones that give way upon impact to help mitigate potential injury in a collision.¹ When you add all of this to the rigidity of laser seam-welded joints that help enhance the strength of every Audi we make, it becomes pretty clear: helping diminish the impact of an unavoidable event doesn't happen by accident.

Airbags

Designed to work in concert with our safety belts and properly-adjusted head restraints, our airbag system is a comprehensive safety measure. Sensors mounted in the front seats monitor your seating position to help ensure that the adaptive front airbags will deploy in the event of a collision.¹ Driver and passenger front seat-mounted thorax side airbags help keep your upper body protected, while knee-level airbags help keep tabs down below. The Audi A5 Coupe even has two rows of Sideguard[®] head curtain airbags for an added level of protection.¹

ABS and ESC

Computerized technology that works in sync with the Anti-lock Brake System (ABS), Electronic Stability Control (ESC) helps minimize loss of stability, applying brake pressure to individual wheels and reducing throttle input to help counter oversteer or understeer when the vehicle needs it.

Active rollover protection system

In the unlikely event that your Audi A5 Cabriolet rolls over, sensors deploy two roll bars from hidden compartments in the rear. Reinforced A-pillars up front and safety belt pretensioners also help protect passengers. It's another way we keep innovative design as high a priority as your safety.



¹ Airbags are supplemental restraints only and will not deploy in all crash circumstances. Always use safety belts and seat children only in the rear, using restraint systems appropriate for their size and age.

Developed to make the best possible use of the body's potential, tailor-made blanks are the result of a special manufacturing process that can help strengthen the upper zone of a B-pillar while mitigating the impact in the lower zone in the event of a side collision.

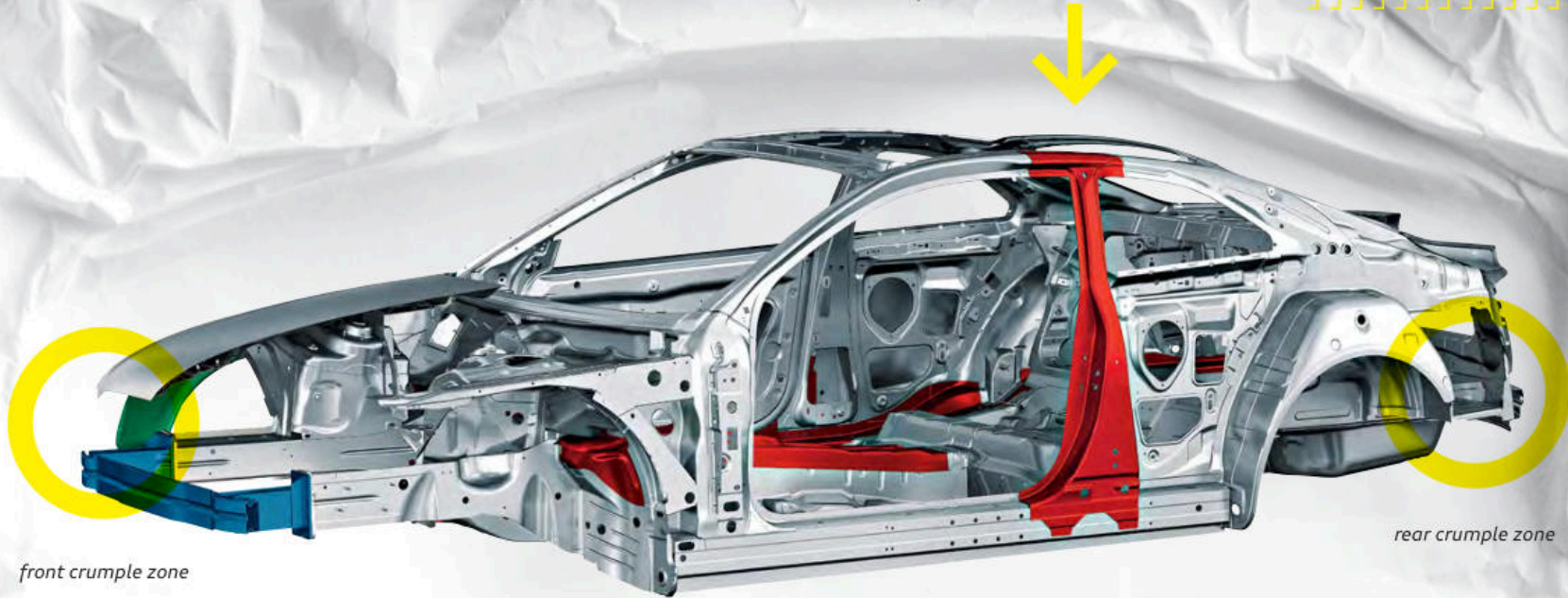

front crumple zone

rear crumple zone



Knautschzone may be an ugly word, but it's a beautiful technology. German for "crumple zone," this ingenious feature helps dissipate the energy from a collision by spreading the impact forces around the passenger cell and away from its occupants. In doing so, it also enhances the vehicle's deceleration rate, which helps to further lessen the force of impact.

- sheet aluminum
- extruded aluminum
- ultra-high-strength steel
- cold-formed steel

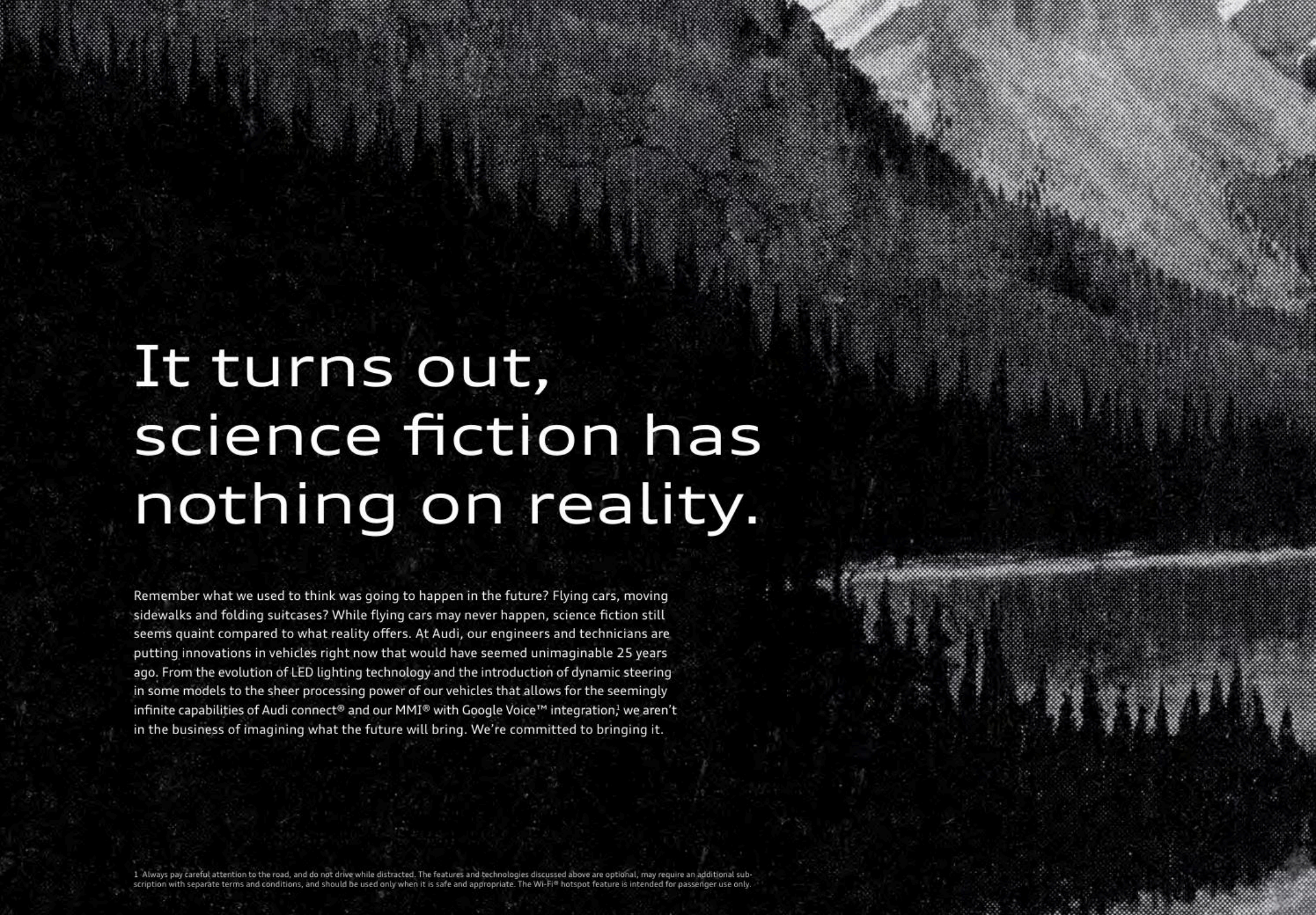
A black and white halftone photograph of a mountain landscape. In the foreground, a calm lake reflects the surrounding forest and mountains. The middle ground is filled with a dense forest of evergreen trees. In the background, a large mountain range is visible, with some peaks appearing to have snow or light-colored rock. The overall texture is a fine, regular grid of dots, characteristic of halftone printing.

It turns out, science fiction has nothing on reality.

Remember what we used to think was going to happen in the future? Flying cars, moving sidewalks and folding suitcases? While flying cars may never happen, science fiction still seems quaint compared to what reality offers. At Audi, our engineers and technicians are putting innovations in vehicles right now that would have seemed unimaginable 25 years ago. From the evolution of LED lighting technology and the introduction of dynamic steering in some models to the sheer processing power of our vehicles that allows for the seemingly infinite capabilities of Audi connect® and our MMI® with Google Voice™ integration,¹ we aren't in the business of imagining what the future will bring. We're committed to bringing it.

¹ Always pay careful attention to the road, and do not drive while distracted. The features and technologies discussed above are optional, may require an additional subscription with separate terms and conditions, and should be used only when it is safe and appropriate. The Wi-Fi® hotspot feature is intended for passenger use only.

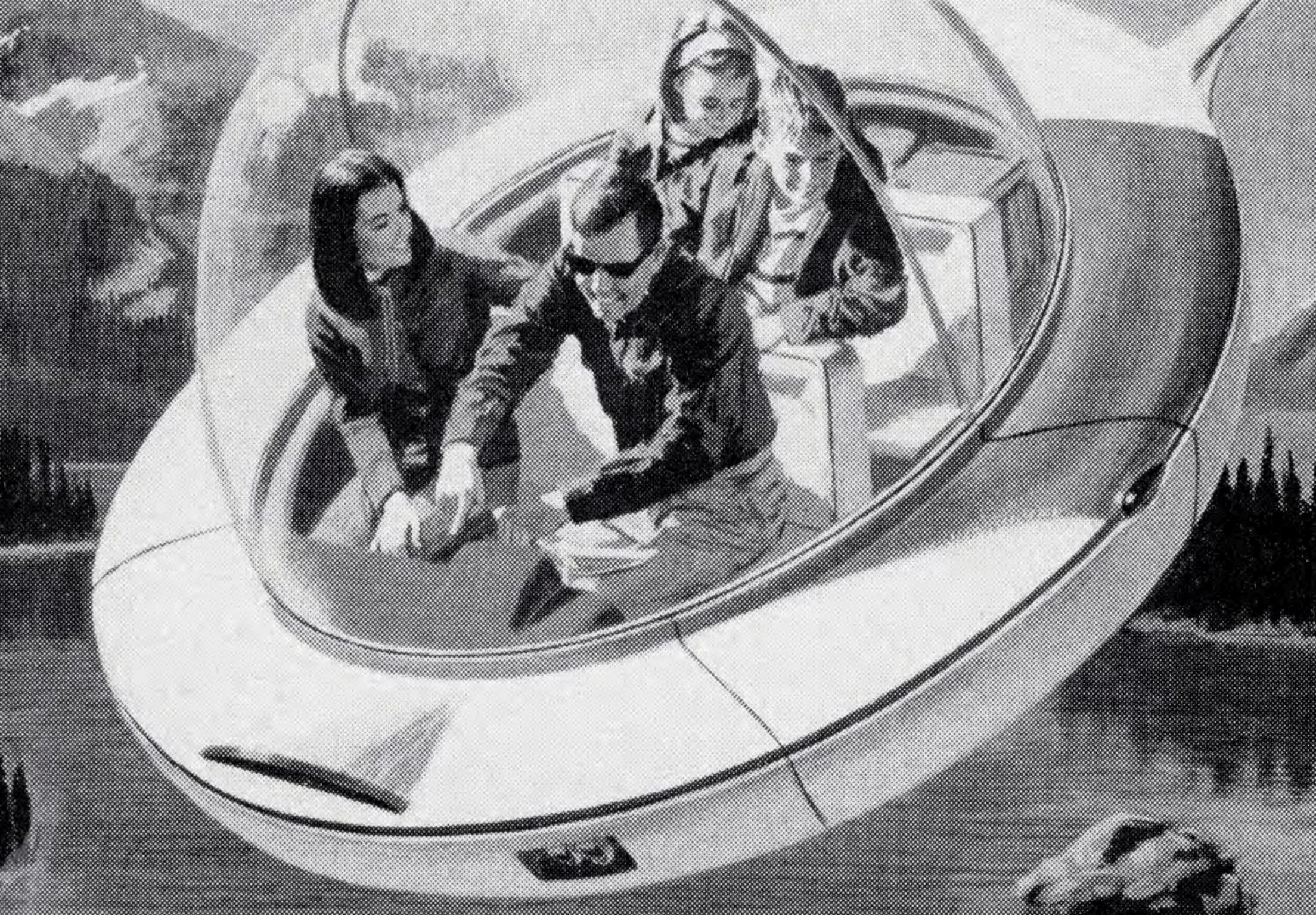

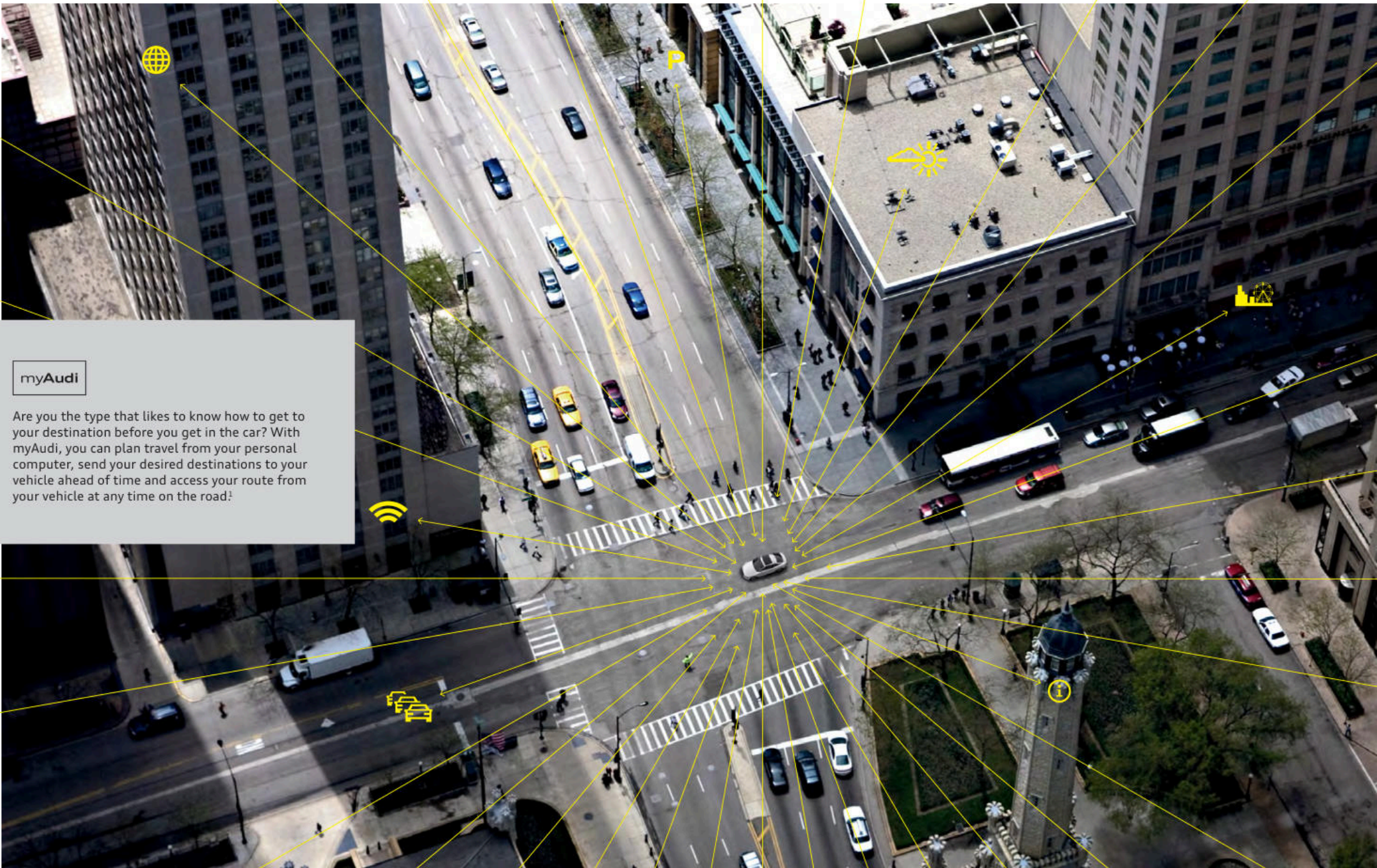

myAudi

Are you the type that likes to know how to get to your destination before you get in the car? With myAudi, you can plan travel from your personal computer, send your desired destinations to your vehicle ahead of time and access your route from your vehicle at any time on the road!

1 Always pay careful attention to the road, and do not drive while distracted. The features and technologies discussed above are optional, may require an additional subscription with separate terms and conditions, and should be used only when it is safe and appropriate. The Wi-Fi® hotspot feature is intended for passenger use only. 2 Voice control not available for all Cabriolet models. 3 SiriusXM® Satellite Radio and SiriusXM® Traffic subscriptions are sold separately or as a package after trial period and are continuous until you call SiriusXM® to cancel. See Customer Agreement for complete terms and more information at www.siriusxm.com. SiriusXM® Traffic service available in select markets. SiriusXM® U.S. Satellite Service available only to those in the 48 contiguous U.S.A., D.C. and Puerto Rico (with coverage limitations). 4 MMI® navigation plus depends on signals from the worldwide Global Positioning Satellite network. The vehicle's electrical system and existing wireless and satellite technologies must be available and operating properly for the system to function. The system is designed to provide you with suggested routes in locating addresses, destinations and other points of interest. Changes in street names, construction zones, traffic flow, points of interest and other road system changes are beyond the control of Audi of America, Inc. Complete detailed mapping of lanes, roads, streets, toll roads, highways, etc., is not possible, therefore you may encounter discrepancies between the mapping and your actual location. Please rely on your individual judgment in determining whether or not to follow a suggested MMI® navigation plus route. For mapping updates please see your Audi dealer or call 1-800-FOR-AUDI for details. 5 Parking feature is not available everywhere and requires participation by parking provider.

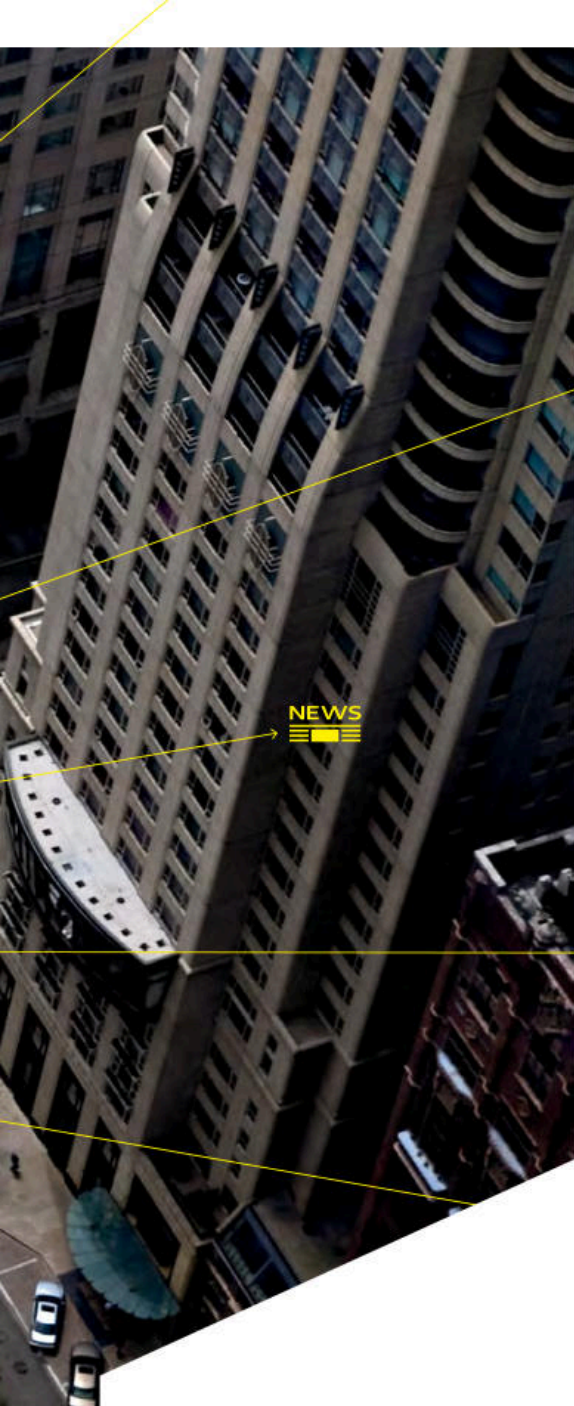

Your central command for the information age.

Sure, the handheld power of smartphones is impressive, but they don't handle like your Audi. Luckily, with active Audi connect[®], you can get nearly all of the functionality of your phone, with the means to get you where you want to go.¹ Need to find a new, highly acclaimed restaurant? Pull over, and with the help of Google Voice Search[™], Audi connect allows you to quickly search Google[™] by simple voice commands? Looking for something to do in a new city? Get information about current events and directions to their locations. With a crisp display and easy access to steering wheel toggle controls, you have a smartcar, which can do even more than the computer in your pocket.

MOBILITY

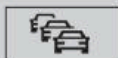

Get SiriusXM[®] Traffic information overlaid onto available 3D satellite imagery to visualize a true aerial view of your route, and let the MMI[®] navigation plus system reconfigure your route to help avoid traffic.^{1,3,4}



With Google Earth[™] integration, you'll enjoy 3D satellite imagery, including Google Street View[™], displayed right on the MMI display.¹



With Google Street View[™], your Audi can show you a driver's-eye view of your destination right before you arrive so it's easy to recognize!¹



Search for parking in your area of interest, check space availability and set your selection as a destination to help navigate directly to the garage entrance.^{1,2,5}

TECHNOLOGY



It's simple. Tell your Audi what you are in the mood for, then let the cloud-processing power of Google[™] speech recognition interpret your request and bring up a list of destinations in the area of your choice.^{1,2}



Staying connected in your Audi has never been easier, with in-vehicle high-speed connectivity. Access is provided for up to eight passenger devices through an onboard Wi-Fi[®] hot spot.¹



The point-of-interest search with voice control means you can get the most out of every journey.^{1,2}

INFORMATION



Get information about current events, exciting locations and places of interest at your travel destination, current location or other chosen location instantly.^{1,2}



Stay on top of the news by having headlines and stories delivered right to your MMI display.^{1,2}



With current local weather conditions and forecasts for your destination, you'll always be prepared for your trip.^{1,2}

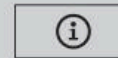

Discover travel information on local landmarks in your area of interest, set them as your destinations and let your vehicle lead the way as you explore the world around you.^{1,2}

Redefining the all-access pass.

Going backstage just got a lot more immersive, and intuitive. The available intelligent MMI® system offers a wealth of easily accessible information, all at the twist of a dial or command of your voice.¹ You'll have access to material such as music files, contact information and destinations. The possibilities are even bigger when you input to Audi connect®, an innovative infotainment system infused with the power of Google™ technology.² With this kind of access, you could say there is no greater stage.

SiriusXM® Satellite Radio

Go ahead. Crisscross the country. We assure you, you'll never run out of entertainment options, with over 150 channels of music, talk, sports and news.³

MMI navigation plus

Count on the available advanced navigation system to home in on your destination with stunning precision while putting a little more depth in your journey with help from Google Earth™.^{2,3}

Audi media

The media function opens up a world of options with the available MMI navigation plus, allowing you to control the Audi music interface, Secure Digital (SD) card slots, available hard disk drive (HDD) audio jukebox or DVD, and available BLUETOOTH® streaming audio from a compatible device.³

BLUETOOTH® wireless technology

Unlock your compatible mobile phone's potential through the MMI system. Simply pair them up and start enjoying near complete control at the touch of a button.

1. Voice control not available for all Cabriolet models. 2. Always pay careful attention to the road, and do not drive while distracted. The features and technologies discussed above are optional, may require an additional subscription with separate terms and conditions, and should be used only when it is safe and appropriate. The Wi-Fi hotspot feature is intended for passenger use only. 3. See pages 44-47 for important information regarding MMI® navigation plus and required SiriusXM® subscriptions.



↓ ↓ ACCESS BUTTONS

Enjoy immediate access to the entire system or customize your vehicle through the MMI, all at the touch of a button.

Orchestrate a more thrilling drive.

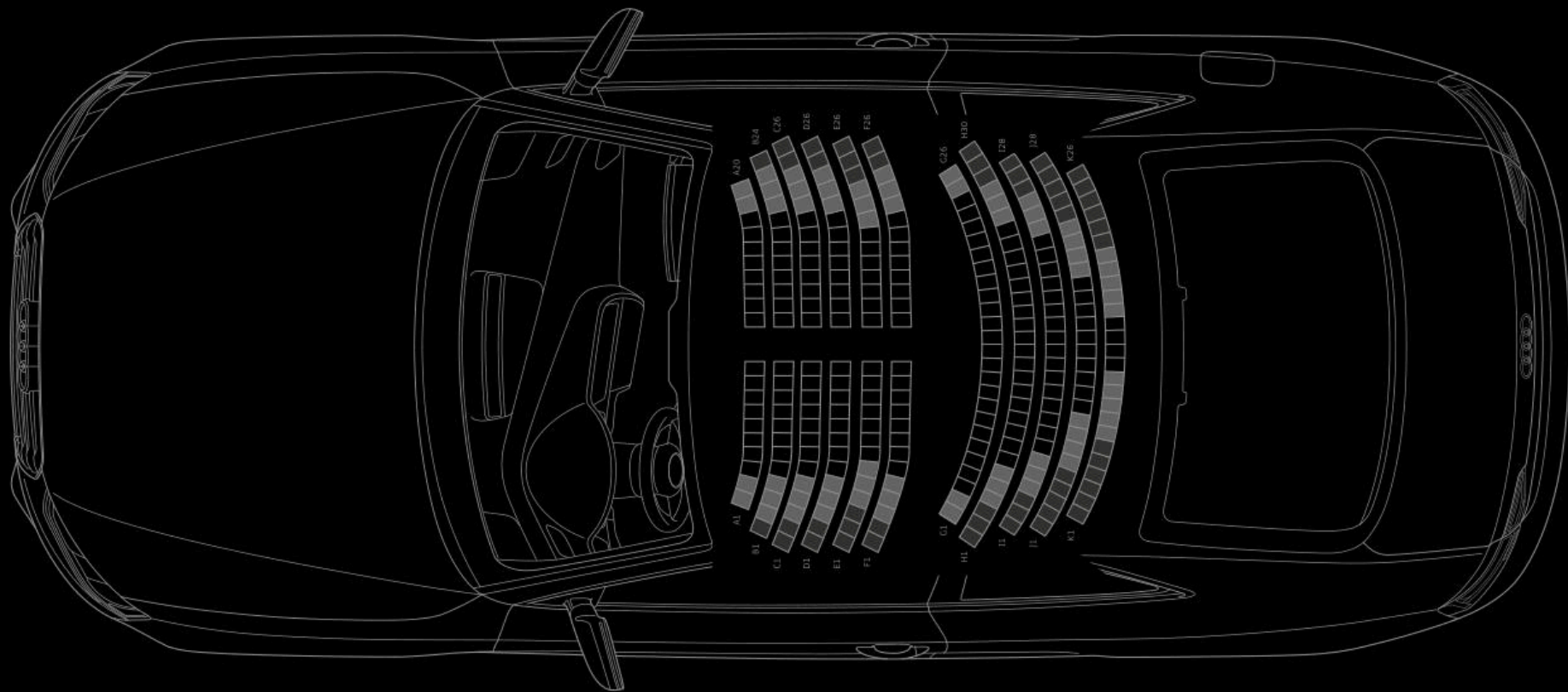

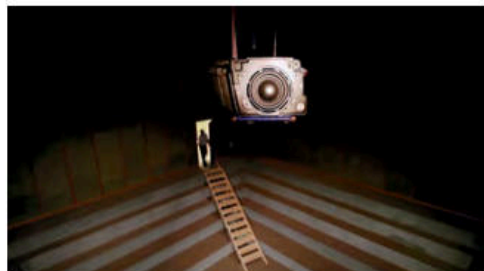

*Over 400 hours of sound tuning
Tested 54,000 times
at speeds up to 155 mph*

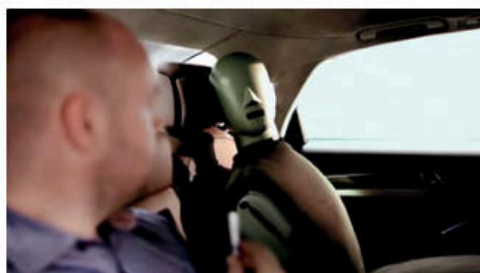
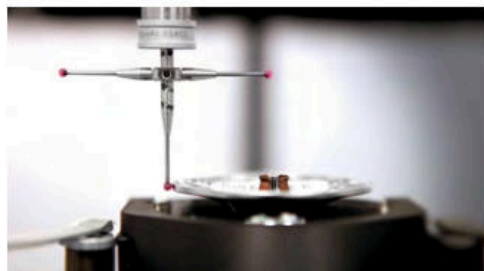

It's been said that people only hear what they want to, that what they don't like just goes in one ear and out the other. Well, for those people and everyone else, we've created a sound system that makes every note worthy of your eardrums' full attention. From perfectly sculpted high notes to a crystal clear mid-range to deep-diving lows, the available Bang & Olufsen® Sound System is a veritable orchestra of engineering that fills the cabin with faithfully rendered, thrilling sound. Which shouldn't be surprising at all, considering that Bang & Olufsen® and Audi sound engineers worked tirelessly to craft a perfect acoustic environment, and the ideal delivery system for it. So whether you're the type that wants to be soothed by sound or the type that wants to be inspired by it, we promise, if you take a moment to listen, that what you'll hear will be utterly impossible to ignore.

Bang & Olufsen® Sound System

Dedicated to the idea of "honest music reproduction," Bang & Olufsen® is a sound engineer's dream. Through an available 505-watt system perfectly integrated within your Audi, Bang & Olufsen® is set on transcending the limits of audio technology. By automatically adjusting volume and timbre balance to changing ambient noise levels and offering richly tuned acoustics, you'll hear the truth about how good life can sound in your Audi.



2016 Audi A5 2.0T Coupe Premium Plus shown in Daytona Gray pearl with available equipment.

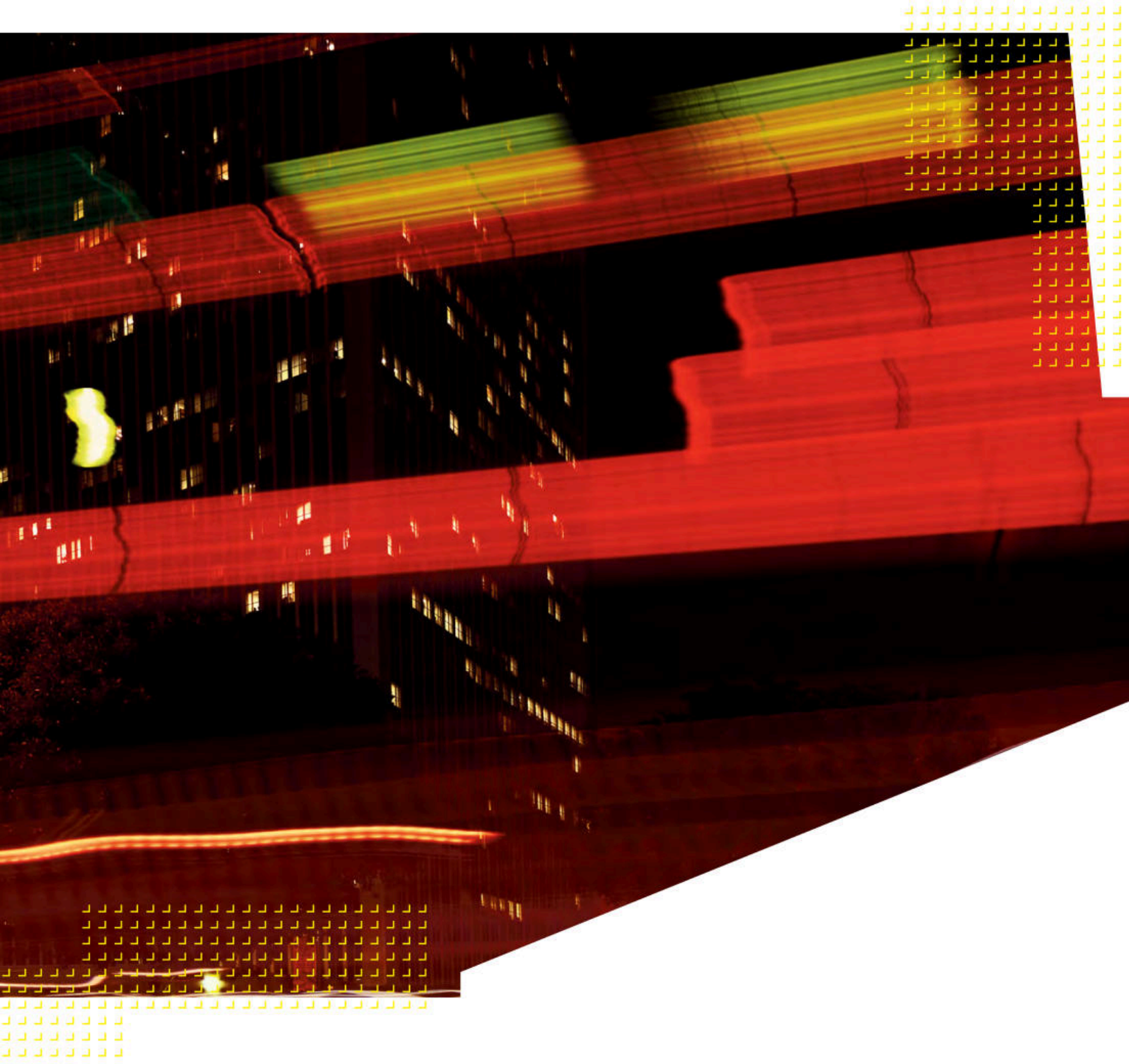

Even at night, the design of the Audi A5 shines brilliantly, particularly when you consider the distinctive design of the LED taillights.

A5

2.0T Premium Coupe/Cabriolet



A5 Premium Featured highlights

Infotainment/Technology

- > Driver information system
- > Audi concert radio with ten speakers and single CD player with MP3 playback capability
- > SiriusXM® Satellite Radio with 90-day trial subscription¹
- > SD card slot with 32GB operating capacity (dual slots if equipped with MMI® navigation plus)²
- > Audi music interface with iPod® integration
- > BLUETOOTH® wireless technology preparation for compatible devices
- > Garage door opener (HomeLink®)
- > Three 12-volt power outlets
- > Cruise control with coast, resume and accelerate features
- > Rain/light sensor for automatic windshield wipers and headlights

Exterior

- > 18" Audi Sport® 10-spoke design wheels with 245/40 all-season tires³
- > Xenon plus headlights with LED daytime running lights
- > LED taillights
- > Power-adjustable heated exterior side mirrors
- > Dual exhaust outlets
- > S line® exterior appearance

Interior/Seating

- > Three-zone automatic climate control
- > Three-spoke multifunction steering wheel
- > Tilt and telescopic manually adjustable steering column
- > Illuminated locking glove box
- > Leather-wrapped shift knob
- > Folding and sliding front center armrest with height adjustment
- > Aluminum Trigon decorative inlays
- > Aluminum door sill inlays
- > Front and rear footwell LED lighting
- > Front and rear floor mats
- > Ambient LED interior lighting
- > Power windows with one-touch up/down operation and pinch protection
- > Wind deflector (Cabriolet)
- > Acoustic folding roof—folds at speeds up to 31 mph (Cabriolet)
- > Panoramic tilting sunroof (Coupe)
- > Leather seating surfaces
- > Ten-way power front seats and four-way power lumbar adjustment for driver
- > Split folding rear seatbacks

Safety

- > Driver and front passenger dual-stage airbags, front thorax side airbags, knee airbags, and Sideguard® head curtain airbags⁴ (Coupe)
- > Driver and front passenger dual-stage airbags, knee airbags, and front head/thorax side airbags⁴ (Cabriolet)
- > Front passenger occupant detection—for airbags⁴
- > Active rollover protection system (Cabriolet)
- > Lower Anchors and Tethers for Children (LATCH) in rear seats (Lower Anchors only on Cabriolet)
- > Electronic Stability Control (ESC) with traction control (ASR)
- > Anti-lock Brake System (ABS) with Electronic Brake-pressure Distribution (EBD) and brake assist
- > Tire-pressure monitoring system
- > Electromechanical parking brake

A5 Premium Stand-alone options

- > Audi advanced key—keyless start, stop and entry⁵
- > 18" 5-arm-dynamic design wheels with 245/40 all-season tires³
- > Heated front seats
- > Dark Brown Walnut Wood decorative inlays
- > Fine Grain Ash Natural Brown Wood decorative inlays

A5 Premium Available packages

Audi MMI® navigation plus package

- > MMI® navigation plus with voice control system² (voice control not available on Cabriolet)
- > Audi connect® with six-month trial subscription⁶
- > Color driver information system
- > HD Radio™ Technology
- > SiriusXM® Traffic with four-year subscription¹
- > BLUETOOTH® streaming audio for compatible devices

¹ SiriusXM® Satellite Radio and SiriusXM® Traffic subscriptions are sold separately or as a package after trial period and are continuous until you call SiriusXM® to cancel. See Customer Agreement for complete terms and more information at www.siriusxm.com. SiriusXM® Traffic service available in select markets. SiriusXM® U.S. Satellite Service available only to those in the 48 contiguous U.S.A., D.C. and Puerto Rico (with coverage limitations). ² MMI® navigation plus depends on signals from the worldwide Global Positioning Satellite network. The vehicle's electrical system and existing wireless and satellite technologies must be available and operating properly for the system to function. The system is designed to provide you with suggested routes in locating addresses, destinations and other points of interest. Changes in street names, construction zones, traffic flow, points of interest and other road system changes are beyond the control of Audi of America, Inc. Complete detailed mapping of lanes, roads, streets, toll roads, highways, etc., is not possible, therefore you may encounter discrepancies between the mapping and your actual location. Please rely on your individual judgment in determining whether or not to follow a suggested MMI® navigation plus route. For mapping updates please see your Audi dealer or call 1-800-FOR-AUDI for details. ³ High-performance tires are designed for better performance and handling in warm climates. When driving in cold, snowy or icy weather, you should equip your vehicle with four all-season or winter tires, which offer better traction under those conditions. We suggest you use the Audi-recommended winter or all-season tires specified for your Audi. High-performance tires also have a lower aspect ratio that aids performance and handling. Driving over rough or damaged road surfaces, as well as debris, curbs and other obstacles, can cause serious damage to wheels, tires, vehicle body and suspension parts. Be careful to avoid road hazards and reduce your speed, especially if your vehicle is equipped with low-profile tires. Please also remember when making your selection that, while these tires deliver responsive handling, they may ride less comfortably and

A5

2.0T Premium Plus Coupe/Cabriolet



A5 Premium Plus Featured highlights



In addition to or replaces highlighted features of A5 Premium

Infotainment/Technology

- > Bang & Olufsen® Sound System with 14 speakers and 505 watts (12 speakers on Cabriolet)
- > Audi advanced key—keyless start, stop and entry⁵

Exterior

- > Power-adjustable, auto-dimming, heated exterior side mirrors with memory

Interior/Seating

- > Auto-dimming interior rear view mirror with digital compass
- > Driver seat memory
- > Heated front seats

A5 Premium Plus Stand-alone options

- > 18" 5-arm-dynamic design wheels with 245/40 all-season tires²
- > 19" 10-spoke design wheels with 255/35 summer performance tires³
- > Dark Brown Walnut Wood decorative inlays
- > Fine Grain Ash Natural Brown Wood decorative inlays

A5 Premium Plus Available packages

Technology package

- > MMI® navigation plus with voice control system² (voice control not available on Cabriolet)
- > Audi connect® with six-month trial subscription⁶
- > Color driver information system
- > HD Radio™ Technology
- > SiriusXM® Traffic with four-year subscription¹
- > BLUETOOTH® streaming audio for compatible devices
- > Audi side assist⁷
- > Parking system with rear view camera (rear acoustic sensors)

Comfort Seat package (Cabriolet)

- > Perforated Milano leather seats
- > Full Milano leather trim elements
- > 14-way power front comfort seats, including four-way power lumbar adjustment
- > Ventilated and heated front seats
- > Head-level heating system

Sport package

- > Sport suspension
- > Shift paddles (automatic transmission)
- > Twelve-way power front sport seats, including four-way power lumbar adjustment
- > Audi drive select

Sport plus package

- > 19" Audi Sport® 5-arm-rotor design Titanium-finish wheels with 255/35 summer performance tires³
- > Gloss Black Singleframe® grille (Coupe)
- > Gloss Black trim around exterior windows (Coupe)
- > Three-spoke multifunction flat-bottom sport steering wheel
- > Shift paddles (automatic transmission)
- > Black cloth headliner (Coupe)

S line® competition plus package (Coupe)

- > 19" Audi Sport® 10-Y-spoke design Gloss Black-finish wheels with 255/35 summer performance tires³
- > Gloss Black Singleframe® grille
- > Gloss Black trim around exterior windows
- > Gloss Black exterior side mirror housings
- > Rear lip spoiler
- > S line® competition plus bumpers with larger air intakes
- > Headlight washing system
- > Three-spoke multifunction flat-bottom sport steering wheel
- > Shift paddles (automatic transmission)
- > S line® competition plus exclusive manual shift knob (manual transmission)
- > Piano Black decorative inlays
- > Black cloth headliner
- > Black leather/Perforated Black Alcantara® seating surfaces—S line® embossed
- > Parking system plus with rear view camera (front and rear acoustic sensors)

make more noise than others. Finally, these tires may wear more quickly than other choices. It is important that the inflation pressure is regularly checked and maintained at recommended levels. ⁴ Airbags are supplemental restraints only and will not deploy in all crash circumstances. Always use safety belts and seat children only in the rear, using restraint systems appropriate for their size and age. ⁵ Some Audi models are equipped with a keyless ignition feature. The details as to how the system works can vary, and Audi owners should consult their owner's literature or an authorized Audi dealer if they have further questions about the operation of this feature. Please note that Audi warns against leaving the vehicle unattended with the engine running, particularly in enclosed spaces. ⁶ Always pay careful attention to the road, and do not drive while distracted. The features and technologies discussed above are optional, may require an additional subscription with separate terms and conditions, and should be used only when it is safe and appropriate. The Wi-Fi® hotspot feature is intended for passenger use only. ⁷ The features discussed are not substitutes for attentive driving. Always check surrounding traffic, and use turn signals. Please see your owner's manual for further details and important limitations.

S5 Premium Plus Coupe/Cabriolet



S5 Premium Plus Featured highlights



In addition to or replaces highlighted features of A5 Premium Plus

Engineering/Performance

- > 3.0-liter supercharged TFSI® V6
- > 333 hp/325 lb-ft torque
- > Acceleration (0-60 mph) in 4.9-5.3 seconds
- > Top track speed of 155 mph¹

Transmission/Suspension/Chassis

- > Six-speed manual transmission or seven-speed S tronic® dual-clutch automatic transmission with steering wheel-mounted shift paddles
- > quattro® all-wheel drive
- > S5 sport suspension
- > 13.6" ventilated front disc/13.0" ventilated rear disc brakes (with S5 badging)

Exterior

- > 18" 5-parallel-spoke S design wheels with 245/40 summer performance tires²
- > Headlight washing system (Coupe)
- > S model quad exhaust outlets
- > S model exterior appearance—Aluminum-optic Singleframe® grille, front/rear twin blades and exterior side mirror housings, body-colored door side sill blades and integrated rear spoiler

Interior/Seating

- > Three-spoke multifunction flat-bottom sport steering wheel
- > Shift paddles (automatic transmission)
- > Brushed Aluminum decorative inlays
- > Leather/Alcantara® seating surfaces—S5 embossed (Coupe)
- > Fine Nappa leather seats and door armrests—S5 embossed (Cabriolet)
- > Twelve-way power front S sport-contoured seats, including four-way power lumbar adjustment

Infotainment/Technology

- > Color driver information system
- > Audi drive select

S5 Premium Plus Stand-alone options

- > Adaptive dampening suspension
- > Sport differential
- > 19" Audi Sport® 7-double-spoke design Silver-finish wheels with 255/35 all-season tires²
- > 19" Audi Sport® 10-Y-spoke design Silver-finish wheels with 255/35 summer performance tires²
- > 19" Audi Sport® 5-arm-rotor design Titanium-finish wheels with 255/35 summer performance tires² (Cabriolet)
- > 245/40 R18 all-season tires^{2,3} (Coupe)
- > Carbon Atlas decorative inlays
- > Layered Aluminum/Black Wood decorative inlays

S5 Premium Plus Available packages

Technology package

- > MMI® navigation plus with voice control system⁴ (voice control not available on Cabriolet)
- > Audi connect® with six-month trial subscription⁵
- > Color driver information system
- > HD Radio™ Technology
- > SiriusXM® Traffic with four-year subscription⁶
- > BLUETOOTH® streaming audio for compatible devices
- > Audi side assist⁷
- > Parking system with rear view camera (rear acoustic sensors)

Comfort Seat package (Cabriolet)

- > Perforated Milano leather seating surfaces
- > Full Milano leather trim elements
- > 14-way power front comfort seats, including four-way power lumbar adjustment
- > Ventilated and heated front seats
- > Head-level heating system

Fine Nappa Leather package (Coupe)

- > Fine Nappa leather seats
- > Leather door armrests and pulls

Black Optic package (Coupe)

- > 19" Audi Sport® 5-arm-rotor design Titanium-finish wheels with 255/35 summer performance tires²
- > Gloss Black Singleframe® grille
- > Gloss Black trim around exterior windows
- > Body-colored exterior side mirror housings

Black Optic plus package (Coupe)

- > 20" Audi Sport® 5-double-spoke design Titanium-finish wheels with 265/30 summer performance tires²
- > Gloss Black Singleframe® grille
- > Gloss Black trim around exterior windows
- > Gloss Black exterior side mirror housings

¹ Top track speed is electronically limited in the U.S. Always obey all speed and traffic laws. ² High-performance tires are designed for better performance and handling in warm climates. When driving in cold, snowy or icy weather, you should equip your vehicle with four all-season or winter tires, which offer better traction under those conditions. We suggest you use the Audi-recommended winter or all-season tires specified for your Audi. High-performance tires also have a lower aspect ratio that aids performance and handling. Driving over rough or damaged road surfaces, as well as debris, curbs and other obstacles, can cause serious damage to wheels, tires, vehicle body and suspension parts. Be careful to avoid road hazards and reduce your speed, especially if your vehicle is equipped with low-profile tires. Please also remember when making your selection that, while these tires deliver responsive handling, they may ride less comfortably and make more noise than others. Finally, these tires may wear more quickly than other choices. It is important that the inflation pressure is regularly

S5

Prestige

Coupe/Cabriolet



S5 Prestige

Featured highlights



In addition to or replaces highlighted features of S5 Premium Plus

Exterior

- > Adaptive xenon plus headlights with LED daytime running light technology
- > Cornering lights—static

Infotainment/Technology

- > MMI® navigation plus with voice control system⁴ (voice control not available on Cabriolet)
- > Audi connect® with six-month trial subscription⁵
- > Color driver information system
- > HD Radio™ Technology
- > SiriusXM® Traffic with four-year subscription⁶
- > BLUETOOTH® streaming audio for compatible devices
- > Audi side assist⁷
- > Parking system with rear view camera (rear acoustic sensors)

S5 Prestige

Stand-alone options

- > Adaptive dampening suspension
- > Sport differential
- > 19" Audi Sport® 7-double-spoke design Silver-finish wheels with 255/35 all-season tires²
- > 19" Audi Sport® 10-Y-spoke design Silver-finish wheels with 255/35 summer performance tires²
- > 19" Audi Sport® 5-arm-rotor design Titanium-finish wheels with 255/35 summer performance tires² (Cabriolet)
- > 245/40 R18 all-season tires^{2,3} (Coupe)
- > Carbon Atlas decorative inlays
- > Layered Aluminum/Black Wood decorative inlays

S5 Prestige

Available packages

Driver Assistance package

- > Dynamic steering
- > Audi adaptive cruise control

Comfort Seat package (Cabriolet)

- > Perforated Milano leather seats
- > Full Milano leather trim elements
- > 14-way power front comfort seats, including four-way power lumbar adjustment
- > Ventilated and heated front seats
- > Head-level heating system

Fine Nappa Leather package (Coupe)

- > Fine Nappa leather seats
- > Leather door armrests and pulls

Luxury package (Coupe)

- > Perforated Milano leather seats
- > Leather door armrests and pulls
- > 14-way power front comfort seats, including four-way power lumbar adjustment
- > Ventilated and heated front seats

Black Optic package (Coupe)

- > 19" Audi Sport® 5-arm-rotor design Titanium-finish wheels with 255/35 summer performance tires²
- > Gloss Black Singleframe® grille
- > Gloss Black trim around exterior windows
- > Body-colored exterior side mirror housings

Black Optic plus package (Coupe)

- > 20" Audi Sport® 5-double-spoke design Titanium-finish wheels with 265/30 summer performance tires²
- > Gloss Black Singleframe® grille
- > Gloss Black trim around exterior windows
- > Gloss Black exterior side mirror housings

checked and maintained at recommended levels. ³ Top track speed lowered to 130 mph. ⁴ MMI® navigation plus depends on signals from the worldwide Global Positioning Satellite network. The vehicle's electrical system and existing wireless and satellite technologies must be available and operating properly for the system to function. The system is designed to provide you with suggested routes in locating addresses, destinations and other points of interest. Changes in street names, construction zones, traffic flow, points of interest and other road system changes are beyond the control of Audi of America, Inc. Complete detailed mapping of lanes, roads, streets, toll roads, highways, etc., is not possible, therefore you may encounter discrepancies between the mapping and your actual location. Please rely on your individual judgment in determining whether or not to follow a suggested MMI® navigation plus route. For mapping updates please see your Audi dealer or call 1-800-FOR-AUDI for details. ⁵ Always pay careful attention to the road, and do not drive while distracted. The features and technologies discussed above are optional, may require an additional subscription with separate terms and conditions, and should be used only when it is safe and appropriate. The Wi-Fi® hotspot feature is intended for passenger use only. ⁶ SiriusXM® Satellite Radio and SiriusXM® Traffic subscriptions are sold separately or as a package after trial period and are continuous until you call SiriusXM® to cancel. See Customer Agreement for complete terms and more information at www.siriusxm.com. SiriusXM® Traffic service available in select markets. SiriusXM® U.S. Satellite Service available only to those in the 48 contiguous U.S.A., D.C. and Puerto Rico (with coverage limitations). ⁷ The features discussed are not substitutes for attentive driving. Always check surrounding traffic, and use turn signals. Please see your owner's manual for further details and important limitations.

Decorative Inlays

A5

Aluminum Trigon

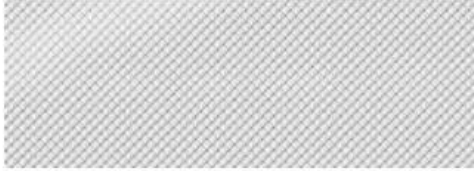

Standard

Dark Brown Walnut Wood



Optional

Fine Grain Ash Natural Brown Wood



Optional

Piano Black



S line® competition plus package (Coupe)

S5

Brushed Aluminum



Standard

Carbon Atlas

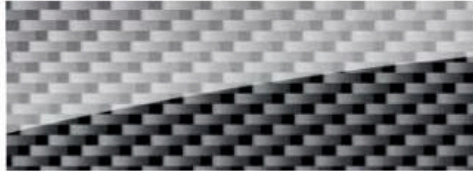

Optional

Layered Aluminum/Black Wood



Optional

A5

18" Audi Sport® 10-spoke design



Standard

18" 5-arm-dynamic design



Optional

19" 10-spoke design



Optional

19" Audi Sport® 5-arm-rotor design
(Titanium finish)

Sport plus package

19" Audi Sport® 10-Y-spoke design
(Gloss Black finish)

S line® competition plus package (Coupe)

S5

18" 5-parallel-spoke S design
(Silver finish)

Standard

19" Audi Sport® 7-double-spoke design
(Silver finish)

Optional

19" Audi Sport® 10-Y-spoke design
(Silver finish)

Optional

19" Audi Sport® 5-arm-rotor design
(Titanium finish)Black Optic package (Coupe)
Optional (Cabriolet)20" 5-double-spoke design
(Titanium finish)

Black Optic plus package (Coupe)

Exterior Colors

Brilliant Black



A5, S5

Ibis White



A5, S5

Florett Silver metallic



A5, S5

Glacier White metallic



A5, S5

Monsoon Gray metallic

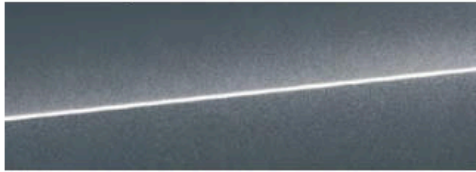

A5, S5

Moonlight Blue metallic

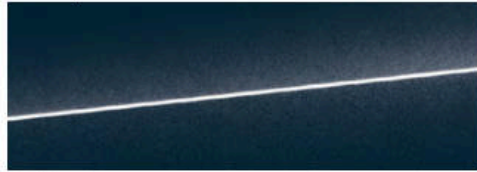

A5, S5

Mythos Black metallic

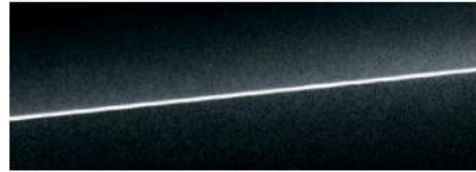

A5, S5

Scuba Blue metallic



A5

Suzuka Gray metallic



A5 S line® competition plus package (Coupe)

Tornado Gray metallic



A5

Utopia Blue metallic



A5

Daytona Gray pearl

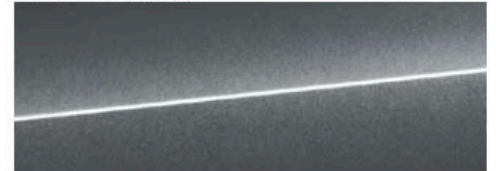

A5 S line® competition plus package (Coupe), S5

Misano Red pearl



A5, S5

Sepang Blue pearl

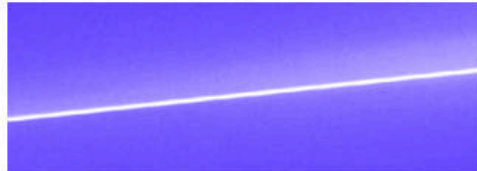

A5 S line® competition plus package (Coupe), S5

Black acoustic folding roof



Red acoustic folding roof



Interior Colors and Seat Selections

A5



Standard Seat



Sport Seat

Black leather



Standard, Sport

Chestnut Brown leather

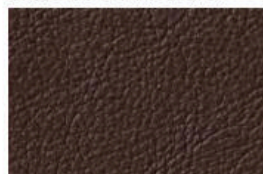

Standard, Sport

Titanium Gray leather

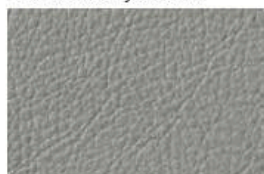

Standard, Sport

Velvet Beige leather

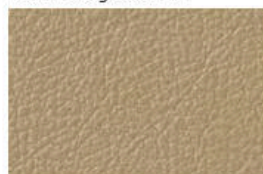

Standard

Black leather/
Perforated Black Alcantara®

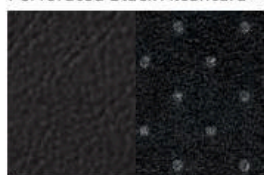

Sport with S line® competition plus package (Coupe)

S5



S5 Sport Seat

Black leather/
Black Alcantara®



Coupe

Black leather/Lunar Silver
Alcantara®



Coupe

Black Fine Nappa leather



Black/Lunar Silver Fine
Nappa leather

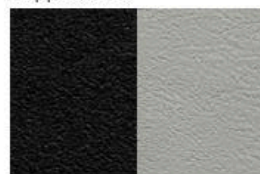

Black/Magma Red Fine
Nappa leather

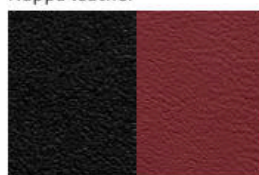

Black/Chestnut Brown Fine
Nappa leather

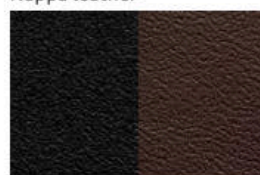

A5 S5



Comfort Seat

Perforated Black
Milano leather



A5 Cabriolet, S5¹

Perforated Chestnut
Brown Milano leather

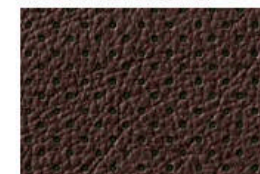

A5 Cabriolet, S5¹

Perforated Titanium
Gray Milano leather

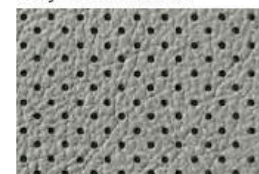

A5 Cabriolet

Perforated Velvet Beige
Milano leather

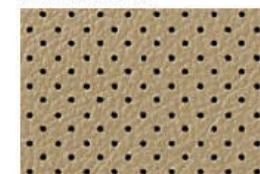

A5 Cabriolet

¹ Head-level heating system not available for Audi S5 Coupe models.

Technical Specifications

Engineering Performance	A5 2.0T Coupe	A5 2.0T Cabriolet	S5 Coupe	S5 Cabriolet
Engine type	Four-cylinder	Four-cylinder	Six-cylinder	Six-cylinder
Engine block/Cylinder head	Cast-iron/ Aluminum-alloy	Cast-iron/ Aluminum-alloy	Aluminum-alloy/ Aluminum-alloy	Aluminum-alloy/ Aluminum-alloy
Displacement (cc)/Bore and stroke (mm)	1,984/82.5 x 92.8	1,984/82.5 x 92.8	2,995/84.5 x 89.0	2,995/84.5 x 89.0
Horsepower (@ rpm)	220 @ 4,450–6,000	220 @ 4,450–6,000	333 @ 5,500–6,500	333 @ 5,500–6,500
Torque (lb-ft @ rpm)	258 @ 1,500–4,300	258 @ 1,500–4,300	325 @ 2,900–5,300	325 @ 2,900–5,300
Compression ratio	9.6:1	9.6:1	10.3:1	10.3:1
Valvetrain	16-valve DOHC with valvelift system	16-valve DOHC with valvelift system	24-valve DOHC with valvelift system	24-valve DOHC with valvelift system
Induction/Fuel injection	Turbocharged/TFSI®	Turbocharged/TFSI®	Supercharged/TFSI®	Supercharged/TFSI®
A5 acceleration with manual/Tiptronic® transmission (0–60 mph)	6.3/6.1 seconds	—/6.6 seconds	—	—
S5 acceleration with manual/S tronic® transmission (0–60 mph)	—	—	4.9/4.9 seconds	—/5.3 seconds
Top track speed ¹	130 mph	130 mph	155 mph	155 mph

Transmission Drivetrain	A5 2.0T Coupe	A5 2.0T Cabriolet	S5 Coupe	S5 Cabriolet
Six-speed manual transmission with quattro® all-wheel drive	■	—	■	—
Eight-speed Tiptronic® automatic transmission with quattro® all-wheel drive	Available	■	—	—
Seven-speed S tronic® dual-clutch automatic transmission with quattro® all-wheel drive	—	—	Available	■

Body Suspension Chassis	A5 2.0T Coupe	A5 2.0T Cabriolet	S5 Coupe	S5 Cabriolet
Fully galvanized steel unibody with aluminum front fenders and multistep anti-corrosion protection	■	■	■	■
Five-link front suspension	■	■	■	■
Trapezoidal-link rear suspension	■	■	■	■
Sport suspension	Available	Available	■	■
Ventilated front disc/Solid rear disc brakes (in)	12.6/11.8	12.6/11.8	—	—
Ventilated front disc/Ventilated rear disc brakes (in)	—	—	13.6/13.0	13.6/13.0
Electromechanical power steering system	■	■	■	■
Dynamic steering	—	—	Available	Available
Steering ratio	15.9:1	15.9:1	15.9:1	15.9:1
Turning diameter, curb-to-curb (ft)	37.4	37.4	37.4	37.4

Exterior measurements	A5 2.0T Coupe	A5 2.0T Cabriolet	S5 Coupe	S5 Cabriolet
Wheelbase (in)	108.3	108.3	108.3	108.3
Length (in)	182.1	182.1	182.7	182.7
Height (in)	54.0	54.4	53.9	54.2
Overall width with mirrors (in)	79.5	79.5	79.5	79.5
Overall width without mirrors (in)	73.0	73.0	73.0	73.0
Track (in, front/rear)	62.6/62.1	62.6/62.1	62.5/62.0	62.5/62.0
Curb weight with manual transmission (lb)	3,583	—	3,858	—
Curb weight with Tiptronic® transmission (lb)	3,682	4,046	—	—
Curb weight with S tronic® transmission (lb)	—	—	3,925	4,310
Drag coefficient (Cw)	.32	.34	.31	.33

Interior measurements				
Head room (in, front/rear)	37.5/36.0	40.0/36.3	37.5/36.0	40.0/36.3
Leg room (in, front/rear)	41.3/31.7	41.3/31.9	41.3/31.7	41.3/31.9
Shoulder room (in, front/rear)	54.3/52.8	54.3/46.8	54.3/52.8	54.3/46.8
Cargo volume (cu ft, rear seatbacks up)	12.2	10.2	12.2	10.2
Seating capacity	4	4	4	4

EPA mileage estimates Capacities Emissions				
Manual transmission (city/highway/combined) ²	NA	—	NA	—
Tiptronic® automatic transmission (city/highway/combined) ²	NA	NA	—	—
S tronic® dual-clutch automatic transmission (city/highway/combined) ²	—	—	NA	NA
Engine oil (qt)	4.9	4.9	7.2	7.2
Fuel (gal)	16.1	16.1	16.1	16.1
Recommended fuel	Premium	Premium	Premium	Premium
Emissions rating	ULEV II	ULEV II	ULEV II	ULEV II

Great lines make the performance more memorable.

We've never felt the need to "compete," but we don't shy away from a challenge, either. This is part of why we developed the available S line® competition plus package. The package's already aggressive appearance is accented by S line competition plus bumpers with larger air intakes, a rear lip spoiler and Gloss Black side mirror housings, window surrounds, Singleframe® grille, side sills, front diffuser and rear diffuser surround. You can also have an advantage of increased awareness provided by a rear view camera and the front and rear sensors of parking system plus. Inside, you'll find Black leather/Perforated Black Alcantara® seating surfaces embossed with the S line logo, Piano Black inlays and available S line competition plus package exclusive aluminum manual shift knob. Striking new Gloss Black Audi Sport® 10-Y-spoke design wheels add even more flair. You'll feel strapped in and ready for the green flag or the green light! So take hold and get ready to receive the attention of passersby and fellow commuters alike.



There's always another story.

Our story doesn't end with this brochure. In fact, we have many more stories to tell at Audi library. Simply download Audi library from the Apple® App StoreSM or Google Play™ store, and you can read everything, from other model and accessory brochures to special-edition pieces to the award-winning *Audi Magazine*. Dive into a massive trove of Audi specs, interactive content, videos, stories and technologies, just by downloading them onto your tablet?

To download the Audi library app onto your device, just follow these steps:

- › Go to the Apple® App StoreSM or Google Play™ store
- › Search for "Audi library"
- › Download the app onto your device²

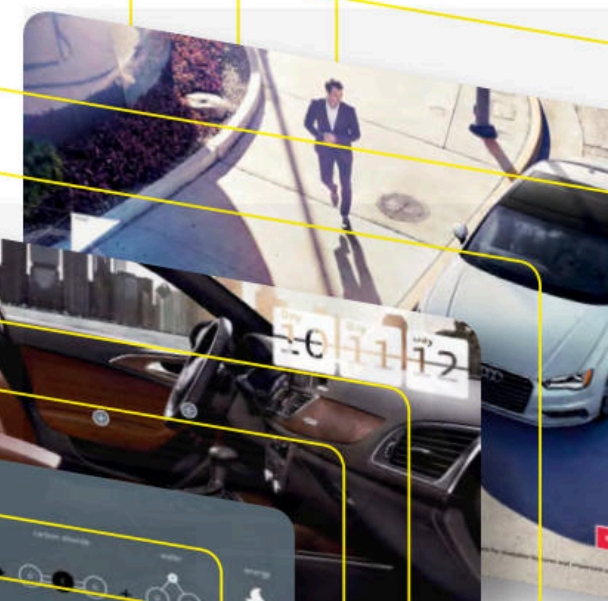
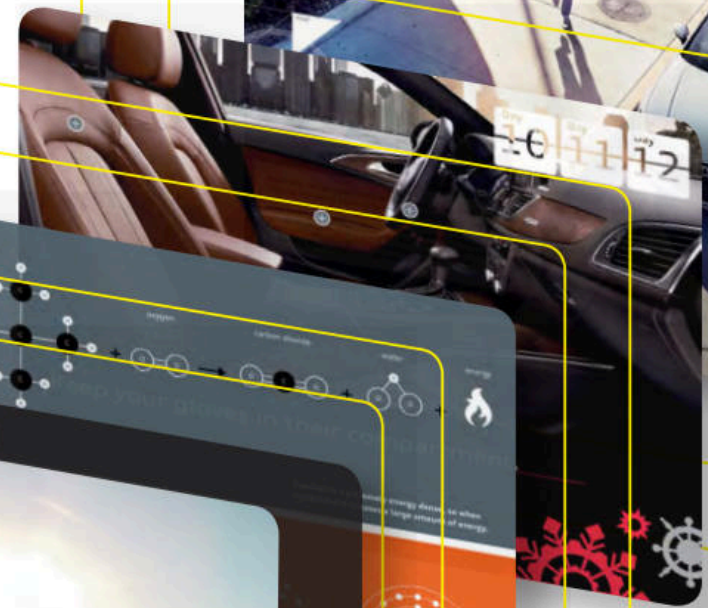

1 Always obey all speed and traffic laws. 2 Standard text and data usage rates apply. Always pay careful attention to the road, and do not drive while distracted.

Audi Genuine Accessories

Add distinction, versatility and the ultimate in self-expression with Audi Genuine Accessories. Whether you load the cargo carrier with climbing gear or add a set of stylish new wheels, we offer accessories to help enhance every facet of your lifestyle. When purchased from an authorized dealer, all pieces are backed by your vehicle's 4-year/50,000-mile limited warranty, or for 12 months/12,000 miles from the accessory purchase date, whichever is greater.¹ If you're looking to personalize or help protect the vehicle you love, we have a solution designed by Audi that works for you.

Audi Genuine Sport and Design Accessories

For a bolder appearance or a finishing touch, we have a solution that helps make every mile more enjoyable—and more yours.

- > Stylish wheel designs
- > Rear spoilers
- > License plate frames

Audi Genuine Electronics Accessories

Our audio options help enhance your listening pleasure, while other accessory options help promote convenience.

- > iPhone® adapter cable
- > Emergency tool
- > Acoustic rear parking system

Audi TravelSpace Transport Accessories

Wherever you go, help make sure everything fits with a variety of intelligent and innovative solutions.

- > Base carrier bars
- > Bike and ski racks
- > Rooftop cargo carriers
- > In-vehicle cargo bags

Audi Guard Comfort and Protection Accessories

Help protect what you love. Use Audi Guard Comfort and Protection Accessories to help keep your Audi looking like new—inside and out.

- > Floor mats
- > Splash guards
- > Cargo mats



Visit parts.audiusa.com to view the full line of Audi Genuine Accessories.



01 Compact cargo carrier

Extra gear won't take up valuable trunk space with this aerodynamic carrier that offers a generous 10.5 cu ft capacity. Size: 76" long, 26" wide, 15" high.²

02 S5 Alu-optic trim package

For the Audi S5 Cabriolet and S5 Coupe, the package includes two "Supercharged" fender badges that are Red or Carbon Fiber, plus Aluminum-optic side sill blades that mount between the wheel wells.

03 Rear spoiler (A5 Coupe only)

This elegant, aerodynamic addition augments the already stylish Audi A5 rear view.

04 19" 5-arm hollow-spoke design wheels

Experience the high-performance beauty of this eye-catching design. The hollow-spoke feature results in a lightweight wheel that helps allow for more precise handling. Shown in Black; also available in Silver or Anthracite.

05 19" 15-spoke design wheels

An impressive, clean, deep-dish design makes this 15-spoke wheel the perfect complement to your A5. Features Ibis White spokes with polished lips. A wheel and tire package is also available in Silver Metallic.

06 Load-protection film

This custom-fit transparent film helps protect the rear bumper from scratches while loading and unloading. The red outline depicts the coverage area.

07 A5 all-weather floor mats

08 S5 all-weather floor mats

Deep-ribbed channeled design helps protect your vehicle's floor and carpeting from water, mud, sand and snow. Black mats are available in sets of two for front or rear. Front mats feature the A5 or S5 logo.

¹ Audi Genuine Accessories purchased from an authorized Audi dealer are covered for the greater of: (1) the accessory limited warranty period (12 months or 12,000 miles, whichever occurs first) from the time of purchase; or (2) the remainder of the Audi New Vehicle Limited Warranty period (48 months or 50,000 miles, whichever occurs first). See your authorized Audi dealer for details. ² All roof-rack system attachments require the base carrier bars. All attachments sold separately.

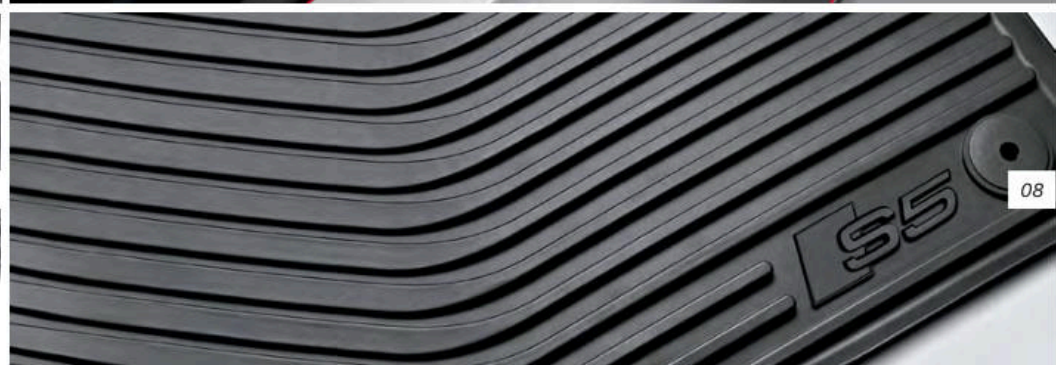
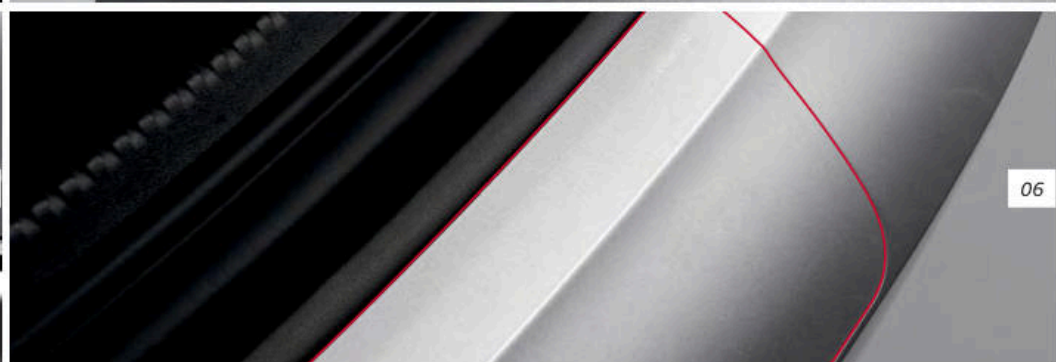



AS
SS
> 2016

Audi of America
AudiUSA.com
Facebook.com/Audi

© 2015
Audi of America, Inc.
Printed in the U.S.A.
AoA1616825

>
>

Note: A word about this brochure. Audi of America, Inc., believes the specifications in this brochure to be correct at the time of printing. However, specifications, standard equipment, options, fabrics, and colors are subject to change without notice. Some equipment may be unavailable when your vehicle is built. Please ask your dealer for advice concerning current availability of standard and optional equipment, and your dealer will verify that your vehicle will include the equipment you ordered. Vehicles in this brochure are shown with optional equipment. See your dealer for complete details on the Audi New Vehicle Limited Warranty, twelve-year limited warranty against corrosion perforation, and Audi 24/7 Roadside Assistance. (Roadside assistance coverage provided by Road America in the U.S. Certain conditions apply; see your dealer for details.) Tires supplied by various manufacturers. "Audi," all model names, "Audi connect," "Audi Sport," "FSI," "MML," "quattro," "Sideguard," "Singleframe" and the Singleframe grille design, "S line," "S tronic," "TFSI," "Truth in Engineering," and the four rings logo are registered trademarks of AUDI AG. "Alcantara" is a registered trademark of Alcantara S.p.A. "Apple" and "iPod" are registered trademarks of Apple Inc. "App Store" is a service mark of Apple Inc. "Bang & Olufsen" is a registered trademark of Bang & Olufsen. The BLUETOOTH word mark and logos are owned by the Bluetooth SIG, Inc., and any use of such marks by AUDI AG is under license. "Google," "Google Earth," "Google Play," "Google Street View," "Google Voice" and "Google Voice Search" are trademarks of Google Inc. "HD Radio" and the HD Radio logo are proprietary trademarks of iBiquity Digital Corporation. "Homelink" is a registered trademark of Johnson Controls Technology Company. "SiriusXM" and all related marks and logos are trademarks of Sirius XM Radio Inc. and its subsidiaries. "Thermocool" is a trademark of INVISTA. "Tiptronic" is a registered trademark of Dr. Ing h.c. F. Porsche AG. "Wi-Fi" is a registered trademark of the Wi-Fi Alliance. All other trademarks are the property of their respective owners. Some European models shown.