

TRUCKS YOU CAN BUILD A REPUTATION ON

2013 GMC COMMERCIAL TRUCKS

WE ARE PROFESSIONAL GRADE.

GMC



2013 COMMERCIAL TRUCKS

TOUGH BUSINESS ENVIRONMENTS DEMAND EVEN TOUGHER TRUCKS. At GMC, we are Professional Grade. That means our engineers design, innovate and build the vehicles professionals choose. They're constantly exceeding expectations and raising the bar for the competition. They built the first pickup with a hydroformed steel frame, eliminating welds and increasing strength. They were the first to push a V-8-powered pickup truck over the 400 hp mark. Innovations such as these have defined GMC throughout our history.

Professionals know they can rely on the safety, technology, power and strength of GMC vehicles, whether it's a Sierra 3500HD Chassis Cab, a Savana Passenger Van, one of GMC's capable and efficient SUVs or a true workhorse, the GMC Sierra 1500. Our dedication is to push the limits of what's possible. Like you, GMC believes that just being good enough is never enough. And that jobs worth doing are worth doing well.

GMC. WE ARE PROFESSIONAL GRADE.



CONTENTS

GMC.COM



SIERRA 2

Sierra says you care about more than getting a job done; you care about doing it well.



SAVANA 18

GMC Savana makes sure no matter where you are, you have what you need to deliver.



YUKON 28

Work that involves carrying up to nine people in comfort demands GMC Yukon.



ACADIA 30

All the benefits of an SUV with all the advantages of a crossover.



TERRAIN 32

A fuel-efficient crossover SUV that's still comfortable and has plenty of cargo space.

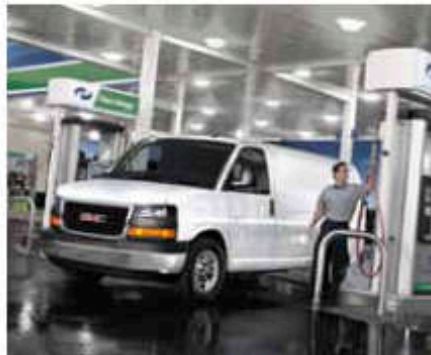

ALTERNATIVE FUEL OFFERINGS 36

Alternative fuels do more than just help the environment—they also help your budget.



FEATURES & TECHNOLOGY 38

With innovative digital and mechanical technologies, GMC helps you get work done.



ACCESSORIES & BUSINESS CHOICE 40

Upfit equipment and incentive options so you can customize your GMC to fit your needs.

SIERRA 1500

BMC.COM

SIERRA WORKS HARDER SO YOU CAN WORK SMARTER. Sierra was engineered to be adapted to fit any task, with intelligent technology to help get the job done better, faster and smarter. There is a wide range of engines, from the budget-friendly 4.3L V-6 to the brute strength of the 6.2L V-8. Partnered with your choice of cab and bed size combinations, Sierra can be configured for jobs both big and small. High-tech interior options, including the Touch-Screen Navigation³ system, help get your crew to the site on time, keeping them on task and projects on schedule.



1 360 DEGREES OF SAFETY

Sierra offers advanced safety features such as standard head curtain side air bags² on 1500 models and available OnStar Directions & Connections.³

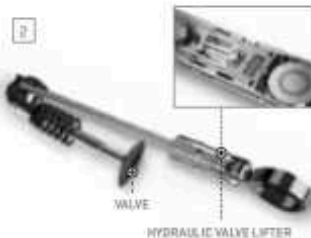

2 ACTIVE FUEL MANAGEMENT (AFM)

Standard on 5.3L gasoline and 6.0L Hybrid V-8s, AFM helps conserve fuel⁴ when extra power isn't needed, such as cruising at highway speeds. AFM triggers hydraulic valve lifters to deactivate four of the eight cylinders to become a V-4. For passing, trailering or mountainous terrain, AFM activates all eight cylinders seamlessly.

COMPETITION-LEADING V-8 EPA-ESTIMATED 22 HWY MPG⁵

Sierra XFE is designed to maximize fuel economy. In addition to the 5.3L VVT V-8 with Active Fuel Management, Sierra XFE is equipped with low rolling resistance tires, lightweight aluminum wheels and spare tire, aluminum suspension components and a lowered suspension that reduces aerodynamic drag. This gives the Sierra XFE all the power of a V-8 with better available V-8 fuel economy on the highway than any other competitor.⁴



SIERRA 1500

HIGHLIGHTS

- The broadest engine lineup in the segment.
- No competitor has better available V-8 fuel economy than Sierra.⁶
- Sierra 1500 XFE gets an EPA-estimated mpg of 15 city and 22 highway.
- The available 6.2L engine with 403 hp and 417 lb-ft of torque is our most powerful 7/2-ton V-8 ever.

Map coverage available in the United States, U.S. Virgin Islands, Puerto Rico and Canada. Air bag inflation can cause severe injury or death to anyone too close to the air bag when it deploys. Be sure every occupant is properly restrained. Always use safety belts, and the correct child restraint for your child's age and size, even with air bags. Each vehicle is equipped with the Passenger Sensing System, which deactivates when properly secured in a rear seat in the appropriate infant, child or booster seat. Never place a rear-facing infant restraint in the front seat of any vehicle equipped with an active frontal air bag. See your vehicle Owner's Manual and child safety seat instructions for more safety information. Visit onstar.com for coverage map, details and system limitations. Sierra Vortec 6.2L V-8 engine EPA-estimated 15 city/22 hwy mpg. Sierra Vortec 6.0L V-8 Hybrid engine EPA-estimated 20 city/23 hwy mpg. Based on 2012 GM Large Pick-up segment. EPA-estimated mpg 15 city/21 hwy with the 5.3L V-8 engine. Based on 2012 GM Large Pick-up segment.



SIERRA 1500 EXTENDED CAB SLE IN SUMMIT WHITE shown with available equipment.

SIERRA HD

GMC.COM

CONVEY CONFIDENCE JUST BY SHOWING UP. When you and your crew arrive at a jobsite in a GMC Sierra HD, it shows serious work is about to get done. Standard on Sierra 2500HD is the 360-horsepower 6.0L Vortec V-8, an engine that provides outstanding power, optimized fuel economy, low emissions and quiet operation. The available Duramax Diesel 6.6L V-8 Turbo engine delivers 397 horsepower and 765 lb-ft of torque and has proved exceptionally durable and dependable over the last decade. Partner the gas engine with dual rear wheels to create a Sierra HD with a payload of up to 7222 lbs.¹ Or pair the available Duramax Diesel with a fifth-wheel hitch and dual rear wheels for maximum trailering of up to 23,100 lbs.²

New for 2013, the CNG/Gasoline Bi-Fuel Sierra 2500HD Extended Cab is designed to help businesses reduce their costs and environmental impact. Powered by our proven 6.0L V-8, the combined 17 Gas Gallon Equivalent (GGE) CNG tank and 36-gallon gasoline tank (approx.) provide a driving range of more than 650 miles.³ Since the fuel delivery and storage system is designed by GMC, the components are engineered to GM durability standards.

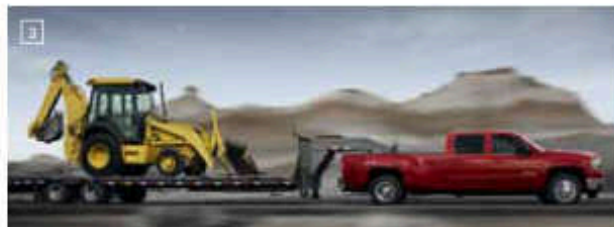

UP TO 18,000 LBS CONVENTIONAL TRAILERING Available 2.5" trailer-hitch receiver enables up to 18,000 lbs maximum conventional towing capacity [2" adapter included].²

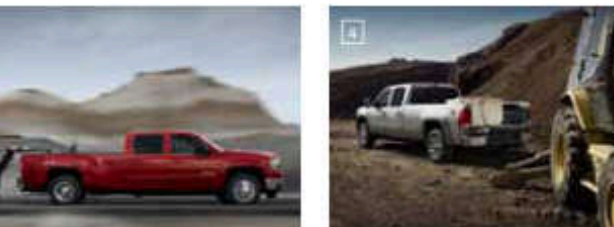

5 FIFTH-WHEEL/GOOSENECK TRAILERING Our engineers reviewed the leading fifth-wheel hitch designs and modified the rear section of the Sierra HD frame to make it easier to install an aftermarket fifth-wheel hitch. This allows a properly equipped Sierra HD to tow up to 23,100 lbs.²

4 SIERRA HD CHASSIS This chassis is designed to improve durability and ride while also supporting increased capability. With fully boxed sections from front to rear, Sierra HD's frame is engineered for a GCWR of up to 30,500 lbs.⁴ and outstanding vibration control. In addition, 3"-wide asymmetrical leaf springs are designed to support the increased loads while contributing to improved ride and handling characteristics.

SIERRA HEAVY DUTY MODELS

HIGHLIGHTS

- With an available Duramax Diesel engine producing 397 hp and 765 lb-ft of torque, the Sierra Heavy Duty is the most powerful GMC HD pickup ever.
- The 2013 GMC Sierra HD offers a best-in-class 1-ton max fifth-wheel trailering capability of 23,100 lbs.²
- The Bi-Fuel Sierra HD Extended Cab uses our proven 6.0L Vortec V-8 and provides a driving range of up to 650 miles.³
- The 2013 GMC Sierra HD offers a max conventional trailering capability of up to 18,000 lbs.²
- The 2013 GMC Sierra HD offers a max payload capacity of up to 7222 lbs.¹

¹Maximum payload capacity includes weight of driver, passengers, optional equipment and cargo. ²Maximum trailer weight ratings are calculated assuming a base vehicle, except for any options necessary to achieve the rating, plus driver. The weight of other optional equipment, passengers and cargo will reduce the maximum trailer weight your vehicle can tow. See your GMC dealer for additional details. ³Based on GM testing and fuel tank capacity. Your range may be less. ⁴When properly equipped, includes weight of the vehicle and trailer combination, including the weight of driver, passengers, fuel, optional equipment and cargo in the vehicle and trailer.



SIERRA 3500HD CREW CAB SLT WITH DUAL REAR WHEELS IN FIRE RED shown with available equipment.



SIERRA CHASSIS CAB

HIGHLIGHTS

- The available Duramax Diesel offers a best-in-class 397 hp and 765 lb-ft of torque.¹
- Sierra Chassis Cab offers a payload of up to 7499 lbs.²
- Sierra Chassis Cab offers a 63.5-gallon fuel tank (approx.) standard on every model.
- Available High Idle Control.

¹Based on 2012 GM Chassis Cab segment. ²Maximum payload capacity includes weight of driver, passengers, optional equipment and cargo. ³When properly equipped. Includes weight of vehicle, passengers, cargo and equipment.



SIERRA CHASSIS CAB

GMC.COM

THE POWER AND STRENGTH YOU EXPECT. THE CONTROL YOU DESERVE. The GMC Sierra Chassis Cab or Box Delete is built for the toughest jobs. With up to 765 lb-ft of torque and 397 horsepower, a payload capacity of up to 7499 lbs² and a GVWR of up to 13,200 lbs,³ the Chassis Cab is designed with power and strength at its core. But make no mistake: its versatility is as important as its power. The lineup offers a choice of a standard Vortec 6.0L V-8 gas engine or an available Duramax Diesel 6.6L V-8. From there, choose from 56", 60" or 84" cab-to-axle lengths as well as Regular, Extended and Crew Cab options. Plus, available features like the diesel exhaust brake and integrated trailer-brake controller add exceptional control to its impressive strength and power.



**SIERRA REGULAR CAB
CHASSIS CAB**

With flatbed



**SIERRA EXTENDED CAB
BOX DELETE**

With service body



**SIERRA CREW CAB
CHASSIS CAB**

With dump body

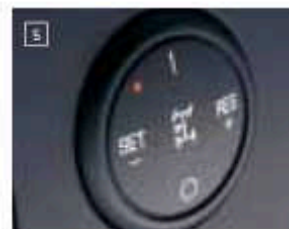

5 AVAILABLE POWER TAKEOFF (PTO) Sierra 3500HD Chassis Cab models equipped with the available Allison[®] automatic transmission have a dash-mounted PTO control to accommodate an aftermarket PTO to drive equipment such as a hydraulic dump body, hydraulic pumps or generators.



6 INTEGRATED TRAILER-BRAKE CONTROLLER Provides immediate and measured brake-force signaling to electric-controlled trailer brake systems. Available on Sierra WT and SLE models.

SIERRA 3500HD CHASSIS CAB WITH DUAL REAR WHEELS IN SUMMIT WHITE shown with available equipment.



SIERRA INTERIOR AVAILABLE FEATURES

HIGHLIGHTS

- Rear-Vision Camera System
- Power-Adjustable Pedals
- Power Rear Sliding Window
- Ultrasonic Rear Parking Assist
- Dual-Level Glove Box
- Multifunctional Center Console Bench Seat

SIERRA CREW CAB INTERIOR IN LIGHT TITANIUM shown with available equipment.



SIERRA INTERIOR

GMC.COM

SOME PEOPLE WITH AN OFFICE INDOORS DON'T HAVE IT THIS COMFORTABLE. Outside is where the work gets done, but inside Sierra is where business gets done. And that's why the Sierra interior is so spacious, comfortable and functional. It starts with a large, quiet cabin perfect for making important calls. Plenty of storage helps you keep essential items close at hand. And finally, premium materials and details make your mobile office comfortable for when you're driving with clients or your crew.

Now consider all the technology features Sierra offers. Bluetooth¹ is available and allows Sierra to connect with your mobile phone. Also available: a 3-month trial of SiriusXM Satellite Radio and, if equipped with a navigation system, a 3-month trial of NavTraffic². That means endless entertainment and priceless real-time traffic information are at your fingertips. Also available is OnStar with the Directions & Connections plan,³ an essential service for someone whose workday is in constant motion.

¹Go to gm.com/bluetooth to find out which Bluetooth phones are compatible with the vehicle. ²If you subscribe after your trial period, subscriptions are continuous until you call SiriusXM to cancel. See SiriusXM Customer Agreement for complete terms at siriusxm.com. Other fees and taxes will apply. All fees and programming subject to change. For more information about NavTraffic, visit siriusxm.com/navtraffic. XM Satellite Service is only available to those in the 48 contiguous USA and DC. ³Visit onstar.com for coverage maps, details and system limitations.



7 SPACIOUS ARMREST STORAGE The front bench seat provides extra storage in the armrest without sacrificing seating comfort (SLE shown).



4 FRONT-ROW UNDER-SEAT STORAGE Sierra offers extra cargo room with a sturdy, lockable compartment easily accessed in this available front bench seat.

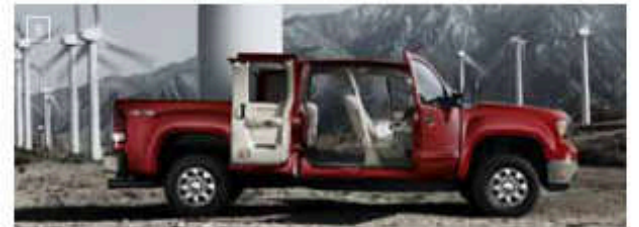

5 170-DEGREE REAR DOOR A GM exclusive our competitors can't match, the standard 170-degree rear door opening on 1500 Extended Cab models

(168 degrees on HD models) makes it easy to fold the seats up, stow and organize cargo. It also provides unmatched access for rear-seat passengers.



SIERRA POWERTRAINS

GMC.COM

THE DURAMAX DIESEL 6.6L V-8 TURBO EMITS LOTS OF POWER. AND NOT MUCH ELSE. At GMC, we never stop searching for ways to improve, and the available Duramax Diesel is a prime example. While Duramax has been a proven engine in the GMC lineup for years, this generation has more: More horsepower, more torque and more fuel efficiency than the previous Duramax engines, all with less tailpipe emissions. It has best-in-class cold-start time and is quieter than before. Most important, the Sierra equipped with the Duramax Diesel gives you an unsurpassed 1-ton GCWR of up to 30,500 lbs¹ as well as 397 hp and 765 lb-ft of torque.

HIGHLIGHTS

- 5-year/100,000-mile (whichever comes first) Powertrain Limited Warranty.²
- Available Duramax Diesel 6.6L V-8 Turbo engine delivers 397 horsepower and 765 lb-ft of torque.
- Available Duramax Diesel 6.6L V-8 Turbo with Allison 1000 transmission offers a maximum highway range of up to 680 miles on a single fill-up.³
- Available Vortec 6.2L V-8 features 403 horsepower and 417 lb-ft of torque.
- Available factory-installed CNG fuel system option reduces costs and environmental impact.

¹When properly equipped, includes weight of the vehicle and trailer combination, including the weight of driver, passengers, fuel, optional equipment and cargo in the vehicle and trailer. ²Whichever comes first. See dealer for details. Fully transferable, no deductible. ³Based on GM testing and fuel tank capacity. Your range may be less. ⁴E85 is a blend of 85 percent ethanol and 15 percent regular gasoline. Visit gmc.com and search E85 for more information on E85 as a fuel alternative.

10 POWER AND EFFICIENCY Count on Sierra's available Duramax Diesel to deliver 397 hp and 765 lb-ft of torque. The Duramax also offers up to 680 highway miles to a tank of fuel.³

DIESEL EXHAUST BRAKE Our "smart" system varies the amount of engine braking needed based on the truck load and grade. It extends the life of your brakes by reducing brake heating and improves safety by reducing brake fade even when towing heavy trailers. Included with the Duramax Diesel engine.

820 BIODIESEL-FUEL COMPATIBLE Our Duramax 6.6L V-8 Turbo engine with diesel direct injection has been developed to meet the stringent 2013 emissions standards, improving emissions by 63 percent from the previous generation. It comes from our advanced selective catalyst reduction and a diesel particulate filter system. To add to its list of capabilities, the Duramax can also run on B20 fuel (a blend of 20 percent biodiesel and 80 percent diesel).

11 ALLISON TRANSMISSION Power is just the beginning of the benefits of the available Duramax Diesel. The available Allison 1000 6-speed automatic allows you to activate Tow/Haul mode simply by pressing a button at the end of the shift lever. Also, by using the +/- button on the column shift lever, drivers can easily select the range of gears they desire for their driving conditions. We call it the Range Selection Mode.

12 VORTEC 5.3L V-8 The available Vortec 5.3L V-8 delivers 315 hp and 335 lb-ft of torque at 4,000 rpm. With fuel-saving Active Fuel Management, it offers up to an EPA-estimated 22 mpg highway.

BI-FUEL VORTEC 6.0L V-8 Our proven 6.0L Vortec V-8 engine has been upgraded with factory-installed hardened exhaust valves and intake/exhaust valve seats allowing it to run on either CNG or gasoline. The combined 17 GGE CNG tank (approx.) and 36-gallon gasoline tank (approx.) provide a range of up to 650 miles.⁴

E85* To give you more choices at the pump, most Vortec V-8 engines are capable of running on E85 ethanol, an advanced biofuel.

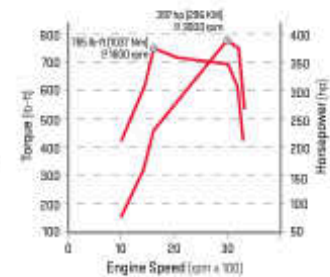

Duramax Diesel 6.6L V-8 Horsepower & Torque - SAE Certified



Allison 1000 Transmission



Vortec 5.3L V-8 VVT Engine

SIERRA HEAVY DUTY FEATURES

SIERRA HD: NEVER UNDERESTIMATE THE POWER OF INNER STRENGTH. At the core of Sierra HD is a backbone that's more rigid, more durable and stronger than previous generations. This latest generation boasts frame strength that has increased by more than 90 percent, and torsional stiffness that has increased by a factor of five. From this strength comes a range of benefits such as a smooth ride and heavy-duty hauling and trailering capabilities. Sierra HD sees enhancements in other key areas, too. This frame provides stronger crossmember mounting for improved frame durability at critical joints.

SNOW PLOW PREP PACKAGE

The Sierra HD front suspension utilizes precision machine-forged-steel upper control arms and huge torsion bars along with the largest steering gear we've ever used on a heavy-duty pickup, supporting a Front Gross Axle Weight Rating of up to 6000 lbs.* So every 4WD HD model can easily accommodate a snow plow with the available Snow Plow Prep Package. The torsion-bar suspension also allows for easy front trim height adjustment when equipment is added or removed.

*When properly equipped, includes weight of vehicle, passengers, cargo and equipment.

INDEPENDENT FRONT

SUSPENSION Larger, stronger parts make the Sierra HD more capable and durable than anything offered before. But that hasn't sacrificed ride quality. Unlike a solid front axle design, the suspension allows the front wheels to react independently to rough terrain, helping keep each wheel in a vertical position. That means you'll enjoy great road isolation, exceptional tire-to-ground contact and reduced tire wear.

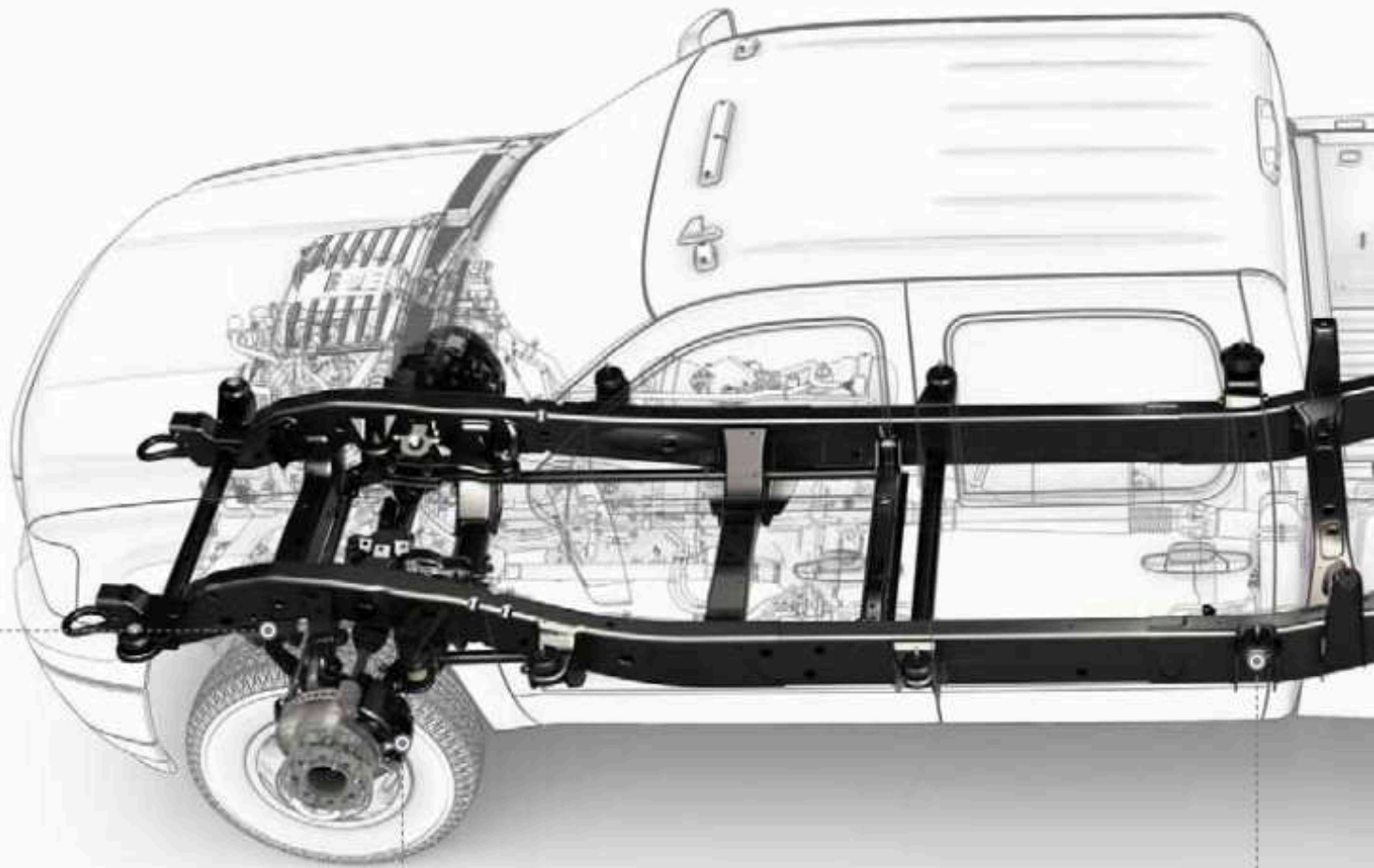

POWER FOUR-WHEEL DISC BRAKES

To help ensure consistent, fade-free performance, the brake discs measure a generous 14" in diameter and utilize twin piston calipers.

HYDRAULIC BODY MOUNTS

On Extended Cab and Crew Cab models, hydraulic body mounts improve ride quality by helping to isolate and absorb bumps.

ALL SIERRA FEATURES

SMC.COM

Z71 OFF-ROAD SUSPENSION PACKAGE The legendary Z71 off-road suspension is available on select versions of the SLE and SLT models. The package includes off-road shocks and jounce bumpers, a 36-mm front stabilizer bar, Skid Plate Package and a high-capacity air cleaner (1500 Series).

LOCKING REAR DIFFERENTIAL AVAILABLE ON 1500/2500 AND STANDARD ON 3500. The Eaton automatic locking rear differential is designed to improve traction at lower speeds. The differential engages when the speed difference between the rear tires reaches approximately 100 rpm. Once the differential engages, both rear wheels rotate at the same speed, providing more of the driveline's torque to the tire with better traction.

6-SPEED TRANSMISSION AVAILABLE ON 1500 AND STANDARD ON 2500/3500. The 6-speed transmission provides two over-drive gears to keep the engine running at lower rpm, and clutch-to-clutch control allows smoother gear changes at lower speeds. Available Tow/Haul mode reduces excessive gear changes on grades and provides auto-grade braking.

TIRE PRESSURE MONITORING SYSTEM If there is a significant reduction in pressure in one or more tires, the Tire Pressure Monitor is designed to activate a low-tire-pressure message in the Driver Information Center, including pressure in each tire. (Standard on 1500 and 2500HD models and 3500HD models with GVWR² less than 10,000 lbs. Does not apply to spare tire.)

²When properly equipped; includes weight of vehicle, passengers, cargo and equipment.

STABILITRAK StabiliTrak with traction control, standard on all single-rear-wheel models, helps your vehicle respond more accurately and predictably to your steering intentions. During difficult driving conditions, sensors feed data to an onboard computer that adjusts steering, engine speed and brake pressure to any individual wheel to help keep you on track.

HILL START BRAKE ASSIST This standard feature with StabiliTrak on all single-rear-wheel models uses the vehicle and trailer brakes (if equipped) to help keep your vehicle and trailer from rolling backward when launching on an incline. By staying engaged for 1.5 seconds, it lets you move your foot from brake to accelerator without fear of rolling.

TRAILER SWAY CONTROL Working with StabiliTrak on single-rear-wheel models, Trailer Sway Control senses trailer sway and applies the truck's brakes and reduces engine power, if necessary, to bring both the vehicle and trailer under control.



FULLY BOXED STEEL FRAME With a fully boxed frame on pickup models, we increased the torsional rigidity and its resistance to twisting as compared to past generations.

REAR SUSPENSION Our latest rear suspension includes springs that increase 20 percent in width over the previous generation. The asymmetrical leaf-spring design on pickup models (shorter in the front than in the rear) reduces "hop and shudder" and includes larger fasteners to handle the increased loads.



SIERRA 1500 SPECIFICATIONS

GMC.COM

S = Standard A = Available - = Not Available

ENGINE AVAILABILITY	SAE NET HP @ RPM	TORQUE (LB-FT) @ RPM	REGULAR CAB		EXTENDED CAB		CREW CAB		HYBRID CREW CAB	
			2WD	4WD	2WD	4WD	2WD	4WD	2WD	4WD
Vortec 4.3L V-6 (262 cu. in.)	195 @ 4600	260 @ 2800	S	S	S ¹	-	-	-	-	-
Vortec 4.8L V-6 (293 cu. in.)	302 @ 5600	305 @ 4800	A	A	A	S	S	S	-	-
Vortec 5.3L V-8 (325 cu. in.)	315 @ 5200	335 @ 4000	A	A	A ²	A ²	A	A	-	-
Vortec 6.0L V-8 Hybrid (364 cu. in.)	332 @ 5100	367 @ 4100	-	-	-	-	-	-	S	S
Vortec 6.2L V-8 (376 cu. in.)	403 @ 5700	417 @ 4300	-	-	A	A	A	A	-	-
TRANSMISSION										
4-Speed Automatic			S	S	S	S	S	S	-	-
6-Speed Automatic			A	A	A	A	A	A	-	-
4-Speed Automatic, Hybrid			-	-	-	-	-	-	S	S
AXLE RATIO										
3.08			A	A	A	A	A	A	S	S
3.23			A	-	A	-	A	-	-	-
3.42			A	A	A	A	A	A	-	-
3.73			A	A	A	A	A	A	-	-
CAPACITY										
GVMR (lbs) ³			6400	6400-6800	6400-7000	7000-7200	6700-7100	7000-7300	7100	7300
Front GAWR (lbs)			3200-3300	3950	3600-3700	3950	3650	3950	3800	3950
Rear GAWR (lbs)			3750	3750-3950	3750-4200	3950-4200	3750-4200	3950-4200	3950	3950
Payload (lbs) ⁴			1635-1840	1545-1827	1515-1908	1513-1835	1589-1937	1623-1890	1527	1509

MAX TRAILERING

Cab Type	Regular Cab		Extended Cab		Crew Cab		Hybrid Crew Cab
	Standard	Long	Standard	Long	Short	Short	
Engine	Vortec 5.3L	Vortec 5.3L	Vortec 5.3L	Vortec 6.2L	Vortec 5.3L	Vortec 5.3L	Vortec 6.2L
Axle Ratio (2WD/4WD)	3.42/3.42	3.42/3.42	3.42/3.42	3.73/3.73	3.42/3.42	3.42/3.42	3.73/3.73
Maximum Trailer Weight (2WD/4WD) ⁵	9100/8900	10,000/9800	9700/9600	10,700/10,400	9500/9300	9600/9500	10,600/10,400

DIMENSIONS

Cab Type	Regular Cab		Extended Cab		Crew Cab	Hybrid Crew Cab
	Standard	Long	Standard	Long	Short	Short
Box Length						
Wheelbase (in.)	119.0	133.0	143.5	157.5	143.5	143.5
Overall Length (in.)	205.6	224.5	230.2	249.2	230.2	230.2
Overall Height (in.)	73.5-73.9	73.5-73.9	73.5-73.9	73.5-73.9	73.5-73.9	73.5-73.9
Cargo Box Length (in.)	78.7	97.8	78.7	97.8	69.3	69.3
Overall Width (in.)	79.9	79.9	79.9	79.9	79.9	79.9
Cab to Axle (in.)	41.9	55.9	41.9	55.9	32.0	32.0
Fuel Tank Capacity in Gallons (approx.)	26	34	26	34	26	26
Standard Wheels (in.)	17	17	17	17	17	18

¹2WD models with Standard Box only. ²Standard on Long Box. ³When properly equipped, includes weight of vehicle, passengers, cargo and equipment. ⁴Maximum payload capacity includes weight of driver, passengers, optional equipment and cargo. ⁵Maximum trailer weight ratings are calculated assuming a base vehicle, except for any option(s) necessary to achieve the rating, plus driver. The weight of other optional equipment, passengers and cargo will reduce the maximum trailer weight your vehicle can tow. See your GMC dealer for additional details.



Regular Cab | Standard Box | 2WD | 4WD



Regular Cab | Long Box | 2WD | 4WD



Extended Cab | Standard Box | 2WD | 4WD



Extended Cab | Long Box | 2WD | 4WD

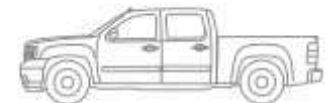

Crew Cab | Short Box | 2WD | 4WD

SIERRA 2500HD SPECIFICATIONS

GMC.COM

S = Standard A = Available - = Not Available

ENGINE AVAILABILITY	SAE NET HP @ RPM	TORQUE (LB-FT) @ RPM	REGULAR CAB		EXTENDED CAB		CREW CAB	
			2WD	4WD	2WD	4WD	2WD	4WD
Vortec 6.0L V-8 HD (366 cu. in.) (Pickup Models)	360 @ 5400	380 @ 4200	S	S	S	S	S	S
Vortec 6.0L V-8 HD (366 cu. in.) (Box Delete Models)	322 @ 4400	380 @ 4200	A	A	A	A	A	A
Vortec 6.0L CNG V-8 (366 cu. in.)	360 @ 5400 gas 301 @ 6000 CNG	380 @ 4200 gas 333 @ 4200 CNG	-	-	A	A	-	-
Duramax Diesel 6.6L V-8 (402 cu. in.)	387 @ 3000	765 @ 1600	A	A	A	A	A	A
TRANSMISSION								
6-Speed Heavy-Duty Automatic with 6.0L			S	S	S	S	S	S
6-Speed Allison Heavy-Duty Automatic with 6.6L Diesel			A	A	A	A	A	A
AXLE RATIO								
3.73:1			S	S	S	S	S	S
4.10:1 (6.0L V-8 engines only)			A	A	A	A	A	A
CAPACITY								
GVWR (lbs) ¹			9300-10,000	9500-9900	9500-10,000	9500-10,000	9500-10,000	9500-10,000
Front GAWR (lbs) Gas			4400	4400 ²	4400	4400-4800	4400	4800 ³
Front GAWR (lbs) Diesel			4800	5200 ⁴	5200	5200-6800 ⁴	5200	5200-5600 ⁴
Rear GAWR (lbs)			6200-6700	6200	6200	6200	6200	6200
Payload (lbs) ⁵			3431-4212	3079-3538	2842-3473	2560-3275	2871-3347	2545-3305

Cah Type	MAX TRAILERING											
	Regular Cab		Extended Cab						Crew Cab			
	Long		Standard		Long		Standard		Long			
Engine	Vortec 6.0L V-8	Duramax Diesel 6.6L V-8	Vortec 6.0L V-8	Vortec 6.0L CNG V-8	Duramax Diesel 6.6L V-8	Vortec 6.0L V-8	Vortec 6.0L CNG V-8	Duramax Diesel 6.6L V-8	Vortec 6.0L V-8	Duramax Diesel 6.6L V-8	Vortec 6.0L V-8	Duramax Diesel 6.6L V-8
Axle Ratio (2WD/4WD)	4.10/4.10	3.73/3.73	4.10/4.10	4.10/4.10	3.73/3.73	4.10/4.10	4.10/4.10	3.73/3.73	4.10/4.10	3.73/3.73	4.10/4.10	3.73/3.73
Maximum Trailer Weight (2WD/4WD) ⁶	14,700/14,400	12,800/12,500	14,300/14,000	13,000/13,000	12,500/16,400	14,200/13,900	13,000/13,000	17,400/15,700	14,200/13,900	17,400/15,800	14,300/13,800	16,700/14,700

Cah Type	DIMENSIONS											
	Regular Cab		Extended Cab						Crew Cab			
	Long		Standard		Long		Standard		Long			
Box Length	Long		Standard		Long		Standard		Long			
Wheelbase (in.)	133.7		144.2		158		153.7		157.7			
Overall Length (in.)	225		230.5		249.5		240.2		259.1			
Overall Height (in.)	714-726		72.8		724-726		724-78.3		725-78.1			
Cargo Box Length (in.) ⁷	97.8		78.7		97.8		78.7		97.8			
Overall Width (in.)	80.0		80		80.0		80		80.0			
Cab to Axle (in.)	56		42.6		55.6		42.6		55.6			
Fuel Tank Capacity in Gallons (approx.) ⁸	36		36		36		36		36			
Standard Wheels (in.)	17		17		17		17		17			

¹When properly equipped, includes weight of vehicle, passengers, cargo and equipment. ²5,200 lbs with available Snow Row Prep Package. ³5,200 lbs with standard box and available Snow Row Prep Package and 5,900 lbs with Long Box and available Snow Row Prep Package. ⁴5,000 lbs with available Snow Row Prep Package. ⁵Maximum payload capacity includes weight of driver, passengers, optional equipment and cargo. ⁶Maximum trailer weight ratings are calculated assuming a base vehicle, except for any option(s) necessary to achieve the rating, plus driver. The weight of other optional equipment, passengers and cargo will reduce the maximum trailer weight your vehicle can tow. See your GMC dealer for additional details. ⁷See your GMC dealer for length of Cargo Box of CNG-equipped models. ⁸See your GMC dealer for additional information on CNG model fuel tank capacities.

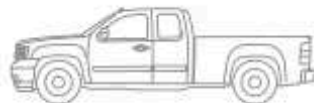
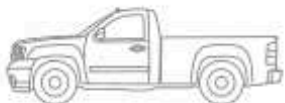

Regular Cab | Long Box | 2WD | 4WD

Extended Cab | Standard Box | 2WD | 4WD

Extended Cab | Long Box | 2WD | 4WD

Crew Cab | Standard Box | 2WD | 4WD

Crew Cab | Long Box | 2WD | 4WD

SIERRA 3500HD SPECIFICATIONS

GMC.COM

S = Standard A = Available - = Not Available

ENGINE AVAILABILITY	SAE NET HP @ RPM	TORQUE (LB-FT) @ RPM	REGULAR CAB				EXTENDED CAB				CREW CAB			
			3500 SRW 2WD ¹	3500 SRW 4WD ²	3500 DRW 2WD	3500 DRW 4WD	3500 SRW 2WD	3500 SRW 4WD ¹	3500 DRW 2WD	3500 DRW 4WD	3500 SRW 2WD ¹	3500 SRW 4WD ¹	3500 DRW 2WD	3500 DRW 4WD
Vortec 6.0L V-8 Heavy Duty (366 cu. in.)	322 @ 4400	380 @ 4200	S	S	S	S	S	S	S	S	S	S	S	S
Duramax Diesel 6.6L V-8 (402 cu. in.)	397 @ 3000	765 @ 1600	A ³	A	A ²	A	A	A	A	A	A	A	A	A
TRANSMISSION														
6-Speed Heavy-Duty Automatic with 6.0L			S	S	S	S	S	S	S	S	S	S	S	S
6-Speed Allison Heavy-Duty Automatic with 6.6L Diesel			A	A	A	A	A	A	A	A	A	A	A	A
AXLE RATIO														
3.73:1			S	S	S	S	S	S	S	S	S	S	S	S
4.10:1 (6.0L V-8 engines only)			A	A	A	A	A	A	A	A	A	A	A	A
CAPACITY														
GVWR (lbs) ⁴			10,400-11,300	10,700-11,400	13,025-13,400	13,025-13,400	10,700-11,200	11,000-11,600	13,025	13,025	10,500-11,400	10,800-11,600	13,025	13,025
Front GAWR (lbs) Gas			4400	4400 ⁵	4400	4400 ⁵	4400	4800 ⁶	4800	4800 ⁶	4400	4800 ⁶	4800	4800 ⁶
Front GAWR (lbs) Diesel			4800 ⁷	5200 ⁸	4800 ⁷	5200 ⁸	5200	5600 ⁹	5200	5600 ⁹	5200	5600 ⁹	5600	5600 ⁹
Rear GAWR (lbs)			7050	7050	9375-9825	9375-9825	7050	7050	9375	9375	7050	7050	9375	9375
Payload (lbs) ¹⁰			4625-5123	4585-4609	6675-7222	5740-6676	4443-4455	4295-4455	5588-6348	5307-6068	3965-4308	4024-4268	5355-6245	5028-5974

MAX TRAILERING	3500HD SRW								3500HD DRW							
	Regular		Extended Cab		Crew Cab		Crew Cab		Regular		Extended Cab		Crew Cab			
Cab Type	Long		Long		Standard		Long		Long		Long		Long			
Engine	Vortec 6.0L V-8	Duramax Diesel 6.6L V-8	Vortec 6.0L V-8	Duramax Diesel 6.6L V-8	Vortec 6.0L V-8	Duramax Diesel 6.6L V-8	Vortec 6.0L V-8	Duramax Diesel 6.6L V-8	Vortec 6.0L V-8	Duramax Diesel 6.6L V-8	Vortec 6.0L V-8	Duramax Diesel 6.6L V-8	Vortec 6.0L V-8	Duramax Diesel 6.6L V-8		
Axle Ratio (2WD/4WD)	4.10/4.10	NA/3.73	4.10/4.10	3.73/3.73	4.10/4.10	3.73/3.73	4.10/4.10	3.73/3.73	4.10/4.10	NA/3.73	4.10/4.10	3.73/3.73	4.10/4.10	3.73/3.73		
Maximum Trailer Weight (2WD/4WD) ¹¹	14,500/14,200	NA/17,400	14,000/13,700	17,300/16,900	14,000/13,700	17,200/17,000	13,900/13,600	17,300/16,900	14,200/13,800	NA/23,100	13,700/13,400	22,800/22,600	13,500/13,200	22,800/22,600		

DIMENSIONS	Regular Cab		Extended Cab		Crew Cab	
	Long	Standard	Long	Standard	Long	Standard
Cab Type	Regular Cab		Extended Cab		Crew Cab	
Box Length	Long		Long		Standard	
Wheelbase (in.)	133.7		158		153.7	
Overall Length (in.)	225		249.5		240.2	
Overall Height (in.)	77.4-77.6		77.4-77.6		77.4-78.3	
Cargo Box Length (in.)	97.8		97.8		76.7	
Overall Width (in.) (SRW/DRW)	80/95.9		80/95.9		80/95.9	
Cab to Axle (in.)	56		56		41.6	
Fuel Tank Capacity in Gallons (approx.)	36		36		36	
Standard Wheels (in.) SRW	18		18		18	
Standard Wheels (in.) DRW	17		17		17	

¹Optional 10,000 lbs GVWR available on single-rear-wheel 3500HD models with gas engine, except 4WD Crew Cab with Long Box. ²Diesel available only with box delete. ³When properly equipped. Includes weight of vehicle, passengers, cargo and equipment. ⁴5,200 lbs with Standard Box and available Snow Plow Prep Package and 5,600 lbs with Long Box and available Snow Plow Prep Package. ⁵5,600 lbs with available Snow Plow Prep Package. ⁶5,200 lbs with available Snow Plow Prep Package. ⁷5,000 lbs with available Snow Plow Prep Package. ⁸Maximum payload capacity includes weight of driver, passengers, optional equipment and cargo. ⁹Maximum trailer weight ratings are calculated assuming a base vehicle, except for any option(s) necessary to achieve the rating, plus driver. The weight of other optional equipment, passengers and cargo will reduce the maximum trailer weight your vehicle can tow. See your GMC dealer for additional details.

SIERRA | 3500HD Series Single Rear Wheel



Regular Cab | Long Box | 2WD | 4WD



Extended Cab | Long Box | 2WD | 4WD



Crew Cab | Standard Box | 2WD | 4WD



Crew Cab | Long Box | 2WD | 4WD

SIERRA 3500HD CHASSIS CAB SPECIFICATIONS

S = Standard A = Available - = Not Available

ENGINE AVAILABILITY	SAE NET HP @ RPM	TORQUE (LB-FT) @ RPM	3500HD DRW REGULAR CAB		3500HD DRW CREW CAB	
			2WD	4WD	2WD	4WD
Vortec 6.0L V-8 Heavy Duty (366 cu. in.)	322 @ 4400	380 @ 4200	S	S	S	S
Duramax Diesel 6.6L V-8 (402 cu. in.)	397 @ 3000	765 @ 1600	A	A	A	A
TRANSMISSION						
6-Speed Heavy-Duty DD Automatic with 6.0L			S	S	S	S
6-Speed Allison Heavy-Duty DD Automatic with 6.6L Diesel			A	A	A	A
AXLE RATIO						
3.73:1			A	A	A	A
4.10:1			A	A	A	A
CAPACITY						
GVWR (lbs) ¹			13,200	13,200	13,200	13,200
Front GAWR (lbs) Gas			4400-4800	4400-5200	4400	4800
Front GAWR (lbs) Diesel			4800-5600	5200-5600	5200	5600
Rear GAWR (lbs)			9750	9750	9750	9750
Payload (lbs) ²			6565-7499	6212-7066	6049-6791	5695-6443

MAX TRAILERING						
Cab Type			Regular Cab		Crew Cab	
Engine			Vortec 6.0L V-8	Duramax Diesel 6.6L V-8	Vortec 6.0L V-8	Duramax Diesel 6.6L V-8
Axle Ratio (2WD/4WD)			4.10/4.10	3.73/3.73	4.10/4.10	3.73/3.73
Maximum Trailer Weight (2WD/4WD) ³			20,500/20,500	27500/27500	20,500/20,500	27500/27500

DIMENSIONS						
Cab Type			Regular Cab		Crew Cab	
Wheelbase (in.)			137.5/162.0		171.5	
Overall Length (in.)			229.5/254.1		263.6	
Overall Height (in.)			77.5		77.5	
Overall Width (in.)			95.6		95.6	
Cab to Axle (in.)			59.8/84.3		59.8	
Fuel Tank Capacity in Gallons (approx.)			63.5		63.5	
Standard Wheels (in.)			17		17	

¹Optional 10,000 lbs GVWR available on Single Rear Wheel 3500HD models with gas engine, except 4WD Crew Cab with Long Box. When properly equipped, includes weight of vehicle, passengers, cargo and equipment. ²Maximum payload capacity includes weight of driver, passengers, optional equipment and cargo. ³Maximum trailer weight ratings are calculated assuming a base vehicle, except for any option(s) necessary to achieve the rating, plus driver. The weight of other optional equipment, passengers and cargo will reduce the maximum trailer weight your vehicle can tow. See your GMC dealer for additional details.

SIERRA | 3500HD Series Dual Rear Wheel

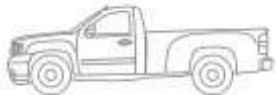

Regular Cab | Long Box | 2WD | 4WD

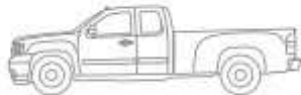

Extended Cab | Long Box | 2WD | 4WD

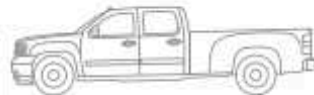

Crew Cab | Long Box | 2WD | 4WD

SIERRA | 3500HD Series Chassis Cab



Regular Cab | 60" and 84" Cab-to-Axle | 2WD | 4WD

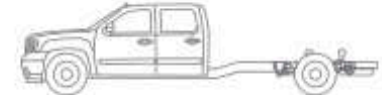

Crew Cab | 60" Cab-to-Axle | 2WD | 4WD

SAVANA CARGO

GMC.COM

ENGINEERED WITH PROFESSIONAL-GRADE PURPOSE. We designed GMC Savana Cargo Van to help prepare you no matter what the workday brings. Choose payload and interior space combinations to suit your needs. The Savana Cargo Van offers a base payload of 2360 lbs (1995 lbs on AWD)¹ and 270.4 cu. ft. of maximum cargo space.² Savana Cargo Extended Wheelbase offers even more capability, with up to 4011 lbs of payload¹ and 313.9 cu. ft. of maximum cargo space.² A variety of fuel systems are available: the standard 4.3L gasoline V-6 with best-in-class EPA-estimated mpg of 15 city and 20 highway,³ our proven Duramax Diesel 6.6L V-8 Turbo enabling you to tow up to 10,000 lbs⁴ or the dedicated CNG/LPG alternative fuel systems that provide operating ranges similar to gas engines while being mindful of the environment. To help you get the most out of Savana, available features like OnStar⁵ and the Rear-Vision Camera System help you maneuver your Savana through today's work environment.

¹Maximum payload capacity includes weight of driver, passengers, optional equipment and cargo. ²Cargo and load capacity limited by weight and distribution. ³Based on GM Large Van segment. ⁴Maximum trailer weight ratings are calculated assuming a base vehicle, except for any option(s) necessary to achieve the rating, plus driver. The weight of other optional equipment, passengers and cargo will reduce the maximum trailer weight your vehicle can tow. See your GMC dealer for additional details. ⁵Visit onstar.com for coverage map, details and system limitations.



DURAMAX The Duramax Diesel 6.6L V-8 Turbo gives you a class-leading diesel 260 hp and 525 lb-ft of torque. Available on all Cargo, Cutaway and select Passenger models.

REMOTE START Start and run your Savana for up to 10 minutes from up to 195 feet away. Perfect pre-heating or -cooling in extreme weather conditions. (Available.)

DRIVER-SIDE CARGO DOORS Savana's GM segment-exclusive available 60/40 driver-side swing-out cargo doors allow the driver to conveniently get to the cargo faster.

TOW/HAUL MODE The available Tow/Haul mode gives the automatic transmission a dual-mode shift program that can hold gears longer to put more torque where it's needed. It also helps provide a smooth transition between gears when climbing hills.

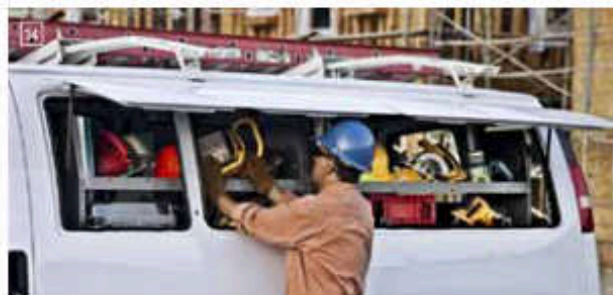

SAVANA PRO Side-access storage bins on the Savana Pro Package maximize underused areas in standard vans. Savana Pro Package has plenty of cargo space and a flat load floor—so it easily adapts to your needs.

REMOTE-RELEASE ENTRY Standard on Savana Pro Package, a push of a button on the remote keyless key fob opens the side panels and helps save time loading and unloading. For security and convenience, the panels lock when pushed closed.

ULTRASONIC REAR PARKING ASSIST At speeds of less than 5 mph, this available system sends out ultrasonic waves that act like rear bumper radar to alert you to the distance of objects up to 8 feet behind the vehicle. The closer you are, the faster it beeps, to give you a clear signal that can help you operate the vehicle with maximum care.

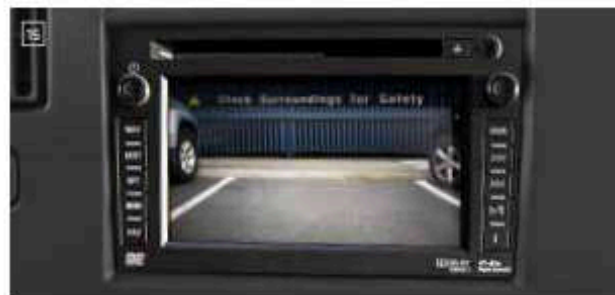

REAR-VISION CAMERA SYSTEM This available system places a monitor in your rearview mirror (or navigation screen, if equipped) to display a view of the area behind the vehicle, making it easier to back up to a trailer or negotiate a tight space.

SAVANA MOBILE OFFICE Stay in touch and productive no matter where the workday takes you. The available dealer-installed Autonet WiFi[®] provides Internet connectivity, while available Bluetooth[®] for phones keeps your mobile devices connected. See page 39 for more details.

[®]Monthly rates apply. Visit gmc.com/mobile for coverage map and details. [®]Go to gmc.com/bluetooth to find out which Bluetooth phones are compatible with the vehicle.

SAVANA CARGO VAN

HIGHLIGHTS

- The Savana Cargo Vans are available in series configurations of 1500, 2500 and 3500 models and in two wheelbases of 135" and 155."
- Ventilated disc brakes are on all four wheels of every Savana.
- Savana Pro has available GM segment-exclusive exterior access (lift) panels.¹
- Available Duramax 6.6L V-8 is the most powerful diesel engine in its class.²
- Savana's engine lineup offers the widest range of available engine displacements, outputs and fuel choices in its class.³
- Savana offers a segment-exclusive AWD system providing sure-footed performance, handling and control on a variety of surfaces.

¹Available on Cargo Van models with 135" wheelbase. ²Based on 2012 GM Large Van segment.



SAVANA 3500 CARGO VAN IN SUMMIT WHITE shown with available equipment.



LEFT: SAVANA 3500 CUTAWAY WITH DUAL REAR WHEELS shown with utility box body and other equipment from an independent supplier. See page 41 for information about alterations and warranties.
RIGHT: SAVANA 3500 CUTAWAY WITH DUAL REAR WHEELS shown with shuttle bus body and other equipment from an independent supplier. See page 41 for information about alterations and warranties.



SAVANA CUTAWAY

GMC.COM

ADAPTS TO YOUR NEEDS. EXCEEDS YOUR EXPECTATIONS. Savana Cutaway can be upfitted for various commercial applications. With the combination of best-in-class maximum payload of 9156 lbs⁵ and maximum GVWR of 14,200 lbs,⁶ along with three wheelbase lengths and dual- and single-wheel options, there's really nothing stopping you from creating the perfect van for your needs. Opt for the 57-gallon fuel tank (approx.), available with a gas V-8 and standard with a diesel V-8, and even refueling won't slow you down. We build versatility and comfort into every Savana to help you maximize your business.

⁵Maximum payload capacity includes weight of driver, passengers, optional equipment and cargo. ⁶When properly equipped, includes weight of vehicle, passengers, cargo and equipment.



CUTAWAY SCHOOL BUS



CUTAWAY SHUTTLE BUS



CUTAWAY WITH AMBULANCE BODY



CUTAWAY WITH UTILITY BOX

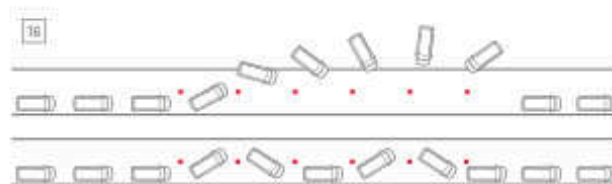

16 STABILITRAK This feature works with Traction Control to help the driver maintain control of the vehicle during difficult driving conditions such as ice, snow, gravel, wet pavement and uneven road surfaces. And when you're trailering, StabiliTrak works directly with the Trailer Sway Control to identify whether your trailer is swaying and uses the power of the engine as well as the braking systems to better maintain control. Only available on SRW models.

DRIVER INFORMATION CENTER

With available features like Bluetooth,⁷ OnStar⁸ and even a separate USB port⁹ to access your iPod,¹⁰ the Driver Information Center keeps you better informed and entertained. You'll know everything, from when you're low on fuel to when your tire pressure is low (except the spare tire), on vans less than 10,000 lbs GVWR.¹¹ See the outside temperature (if equipped), receive maintenance reminders and more—all to keep you running safely and efficiently.

⁷Go to gmc.com/bluetooth to find out which Bluetooth phones are compatible with the vehicle. ⁸Visit onstar.com for coverage map, details and system limitations.

⁹Not compatible with all devices. ¹⁰When properly equipped, includes weight of vehicle, passengers, cargo and equipment.

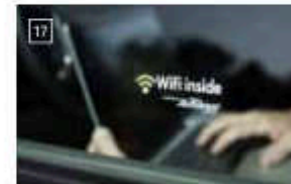

EATON AUTOMATIC LOCKING REAR DIFFERENTIAL

When the available Eaton locker senses a 100 rpm difference in wheel speed between the left and right rear wheels, it locks both to turn in unison for added traction.

17 SAVANA MOBILE OFFICE

Available Autonet WiFi¹¹ and Bluetooth connectivity turn Savana into a fully functional mobile office, allowing employees to work from nearly anywhere. See page 39 for more details.

¹¹Monthly rates apply. Visit autonetmobile.com for coverage map and details.

SAVANA CUTAWAY

HIGHLIGHTS

- Savana Cutaway is available in 139", 159" and 177" wheelbases.
- Savana Cutaway has a large range of GVWRs: 9900-12,300 lbs (139" wheelbase), 10,050-14,200 (159" wheelbase) and 12,300 (177" wheelbase).¹
- Available audio system with Navigation,² AM/FM stereo, CD/MP3 player, USB port³ and SiriusXM⁴ with 3-month trial.
- Available Automatic Rear Locking Differential improves low-speed traction and helps your ability to handle slippery road conditions.
- StabiliTrak is available on all SRW models.

¹When properly equipped, includes weight of vehicle, passengers, cargo and equipment. ²Map coverage available in the United States, U.S. Virgin Islands, Puerto Rico and Canada. ³Not compatible with all devices. ⁴When you subscribe after your trial period, subscriptions are comparable to other SiriusXM services. See SiriusXM Customer Agreement for complete terms at siriusxm.com. Other fees and taxes will apply. All fees and programming subject to change. XM satellite service is available only to those in the 48 contiguous USA and DC.



PASSENGER VANS

SAFETY ISN'T JUST A PRIORITY. IT'S YOUR BUSINESS. We understand "safety first." Our Savana Passenger Van comes standard with head curtain side-impact air bags¹ to protect passengers in the front rows and enhanced-technology glass in the rearmost side windows to help protect passengers in the fourth and fifth rows on extended-wheelbase models. Savana also comes standard with StabiliTrak and ABS. Or you can opt for the added security benefits of DnStar.² Whether Savana is configured to seat eight, 12 or 15 passengers, all passengers ride in superb comfort. Our Savana Passenger Van can also facilitate mobility equipment installation. Wheelchair lifts, ramps, running boards and other driver aids, available from independent aftermarket suppliers,³ can be installed.

¹Always use safety belts and the correct child restraint for your child's age and size, even with air bags. Even in vehicles equipped with the Passenger Sensing System, children are safer when properly secured in a rear seat in the appropriate infant, child or booster seat. Never place a rear-facing infant restraint in the front seat of any vehicle equipped with an active frontal air bag. See your vehicle Owner's Manual and child safety seat instructions for more safety information. ²Visit onstar.com for coverage map, details and system limitations. ³Equipment added by an independent supplier. See page 41 for information about alterations and warranties. Rear-entertainment plans are available. See dealer for details or go to gm.com. ⁴Available on Passenger and Cargo Van 1500 Series 135" wheelbase models only. ⁵Based on 2012 GM Large Van segment.

HIGHLIGHTS

- Savana offers available GM segment-exclusive all-wheel drive.⁴
- Savana was the first full-size van in its class to offer StabiliTrak.⁵
- Savana Passenger Vans offer the broadest V-8 engine lineup in the segment.⁶
- Head curtain side-impact air bags¹ help provide protection for outboard occupants in the first three seating rows.
- On extended-wheelbase models, three-layer special-technology glass for the fourth and fifth rows is designed to help reduce the risk of ejection during a crash.

SAVANA 3500 PASSENGER VAN IN DEEP BLUE METALLIC shown with available equipment (left).
SAVANA 1500 CARGO VAN IN SUMMIT WHITE shown with available equipment (right).



GMC.COM

STABILITRAK To help you stay in control when the road is loose, snowy, icy, wet or uneven, StabiliTrak uses a network of vehicle sensors to monitor how your Savana is responding to your steering and braking commands. If the system determines your vehicle is not responding properly, it can pulse the brakes or reduce engine power to help you stay on the path being steered.



SAVANA MOBILE OFFICE Stay in touch and productive no matter where the workday takes you. Available dealer-installed Autonet WiFi[®] provides Internet connectivity, while available Bluetooth[®] for phones keeps your mobile devices connected.

*Monthly rates apply. Visit autonetmobile.com for coverage map and details. †Go to gmc.com/bluetooth to find out which Bluetooth phones are compatible with the vehicle.

18 ALL-WHEEL DRIVE (AWD) Available on the 1500 Series, this innovative AWD system constantly monitors and adjusts torque quickly and seamlessly between the front and rear wheels for optimum balance and control, giving you extra confidence in a variety of driving conditions.

19 MULTIPLE PASSENGER CONFIGURATIONS With two wheelbase choices, three model series and three basic seating arrangements, Savana Passenger Vans can accommodate up to eight passengers in 1500 Series models, up to 12 passengers in 2500 and 3500 Series 135" wheelbase models or up to 15 passengers in the 3500 Series 155" wheelbase models.

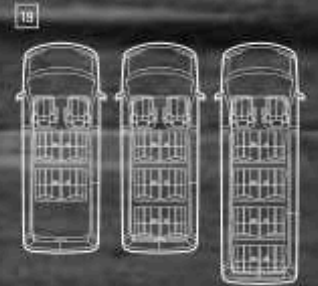

SAVANA PASSENGER VAN SPECIFICATIONS

GMC.COM

S = Standard A = Available - = Not Available

ENGINE AVAILABILITY	SAE NET HP @ RPM	TORQUE (LB-FT) @ RPM	1500 RWD	1500 AWD	2500 RWD	3500 RWD	3500 Ext RWD
Vortec 4.3L V-6	195 @ 4600	260 @ 2900	-	-	-	-	-
Vortec 4.8L FlexFuel V-8	280 @ 5200	296 @ 4500	-	-	S	S	S
Vortec 5.3L FlexFuel V-8	310 @ 5200	334 @ 4500	S	S	-	-	-
Vortec 6.0L FlexFuel V-8	324 @ 4700	373 @ 4400	-	-	A	A	A
Duramax Diesel 6.6L V-8	260 @ 3100	525 @ 1600	-	-	-	A	A
Vortec 6.0L CNG V-8	282 @ 4800	320 @ 4400	-	-	-	-	-
TRANSMISSION							
4-Speed OD Automatic			S	S	-	-	-
6-Speed Automatic			-	-	S	S	S
CAPACITY							
GVWR (lbs) ¹			7300	7300	8600	9600	9600 ²
Front GAWR (lbs)			3600	3700	4100	4600	4600
Rear GAWR (lbs)			4000	4000	5360	6084	6084
Maximum Payload (lbs) ³			1775	1560	2705	3481	3771
PASSENGER VAN DOOR AND SEATING CONFIGURATIONS							
Right-Hand Passenger-Side 60/40 Swing-Out Doors			S	S	S	S	S
Right-Hand Passenger-Side Sliding Door			A	A	A	A	A
Rear Swing-Out Doors			S	S	S	S	S
8-Passenger Seating			S	S	A	A	-
12-Passenger Seating			-	-	S	S	S
15-Passenger Seating			-	-	-	-	A

MAX TRAILERING	1500		2500		3500					
	135" RWD	136" AWD	136"		135"		Duramax Diesel 6.6L V-8		155"	
Wheelbase	135" RWD	136" AWD	136"		135"		Duramax Diesel 6.6L V-8		155"	
Engine	5.3L V-8	5.3L V-8	4.8L V-8	6.0L V-8	4.8L V-8	6.0L V-8	Duramax Diesel 6.6L V-8	4.8L V-8	6.0L V-8	Duramax Diesel 6.6L V-8
Axle Ratio	3.73	3.73	3.42	3.42	3.42	3.42	3.54	3.42	3.42	3.54
Maximum Trailer Weight ⁴	6200	6000	6700	9800	6700	9700	10,000	8400	9300	9700

DIMENSIONS	135" WHEELBASE		155" WHEELBASE	
	135" RWD	136" AWD	135" RWD	155" RWD
Overall Length (in.)	224		244	
Overall Height (in.)	81.5-83.7		82.9	
Overall Width (in.)	79.2		79.2	
Side-Door Height (in.)	47.9		47.9	
Side-Door Width (in.)	44.1		44.1	
Rear-Door Opening Width (in.)	57		57	
Rear-Door Opening Height (in.)	49.4		49.4	
Max Cargo Space (cu. ft.) ⁵ with seats removed	216.2		252.9	
Fuel Tank Capacity in Gallons (approx.)	31		31	
Wheels (in.) 1500 only	17		-	
Wheels (in.) 2500/3500 only	16		16	

¹E85 is a blend of 85 percent ethanol and 15 percent regular gasoline. Go to gmc.com and search E85 for more information about E85 as a fuel alternative. ²When properly equipped, includes weight of vehicle, passengers, cargo and equipment. ³GVWR with Duramax Diesel is 9900 lbs. ⁴Maximum payload capacity includes weight of driver, passengers, optional equipment and cargo. ⁵Maximum trailer weight ratings are calculated assuming a base vehicle, except for any option(s) necessary to achieve the rating, plus driver. The weight of other optional equipment, passengers and cargo will reduce the maximum trailer weight your vehicle can tow. See your GMC dealer for additional details. ⁶Cargo and load capacity limited by weight and distribution.

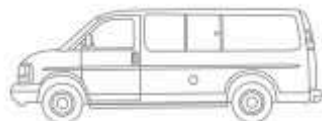

1500 | 135" WB | RWD | AWD

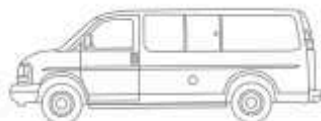

2500 | 135" WB | RWD

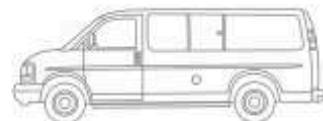

3500 | 135" WB | RWD

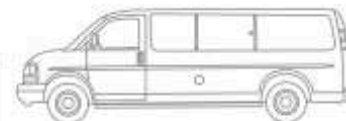

3500 | 155" WB | RWD

SAVANA CARGO VAN SPECIFICATIONS

GMC.COM

S = Standard A = Available -- = Not Available

ENGINE AVAILABILITY	SAE NET HP @ RPM	TORQUE (LB-FT) @ RPM	1500 RWD	1500 AWD	2500 RWD	2500 Ext RWD	3500 RWD	3500 Ext RWD
Vortec 4.3L V-6	195 @ 4600	260 @ 2800	S	--	--	--	--	--
Vortec 4.8L FlexFuel ¹ V-6	280 @ 5200	295 @ 4600	--	--	S	S	S	S
Vortec 5.3L FlexFuel ¹ V-6	310 @ 5200	334 @ 4500	A	S	--	--	--	--
Vortec 6.0L FlexFuel ¹ V-6	324 @ 4700	375 @ 4400	--	--	A	A	A	A
Duramax Diesel 5.6L V-8	250 @ 3100	325 @ 1600	--	--	A	A	A	A
Vortec 6.0L CNG V-8	282 @ 4800	320 @ 4400	--	--	A	--	A	--
TRANSMISSION								
4-Speed OD Automatic			S	S	--	--	--	--
6-Speed Automatic			--	--	S	S	S	S
CAPACITY								
GVWR (lbs) ²			7300	7300	8600	8600	9600	9600 ³
Front GAWR (lbs)			3600	3700	4100	4300	4500	4300
Rear GAWR (lbs)			4000	4000	5360	5360	6084	6084
Maximum Payload (lbs) ⁴			2360	1995	3287	3073	4372	4011
CARGO VAN DOOR CONFIGURATIONS								
Right-Hand 60/40 Swing-Out Cargo Doors			S	S	S	S	S	S
Right-Hand Sliding Door			A	A	A	A	A	A
Left-Hand 60/40 ⁵ Swing-Out Cargo Doors			A	A	A	--	A	--
Rear Swing-Out Cargo Doors			S	S	S	S	S	S
Savana Pro Side Access Panels			A	A	A	--	A	--

MAX TRAILERING	1500			2500						3500					
	135" RWD		135" AWD	135"			155"			135"			155"		
Wheelbase															
Engine	4.3L V-6	5.3L V-8	5.3L V-8	4.8L V-8	6.0L V-8	Duramax Diesel 6.6L V-8	4.8L V-8	6.0L V-8	Duramax Diesel 6.6L V-8	4.8L V-8	6.0L V-8	Duramax Diesel 6.6L V-8	4.8L V-8	6.0L V-8	Duramax Diesel 6.6L V-8
Axle Ratio	3.42	3.73	3.42	3.42	3.42	3.54	3.42	3.42	3.54	3.42	3.42	3.54	3.42	3.42	3.54
Maximum Trailer Weight ⁶	4300	6700	6500	7400	10,000	10,000	7200	10,000	10,000	7400	10,000	10,000	7100	10,000	10,000

DIMENSIONS	135" WHEELBASE				155" WHEELBASE			
	Overall Length (in.)	224				244		
Overall Height (in.)	81.5-83.7				82-82.8			
Overall Width (in.)	75.2				75.2			
Side-Door Height (in.)	47.9				47.9			
Side-Door Width (in.)	45.3				45.3			
Rear-Door Opening Width (in.)	57				57			
Rear-Door Opening Height (in.)	48.4				48.4			
Max Cargo Space (cu. ft.) ⁷ with seats removed	270.4				313.9			
Fuel Tank Capacity in Gallons (approx.)	31				31			
Wheels (in.) 1500 only	17				--			
Wheels (in.) 2500/3500 only	18				16			

¹E85 is a blend of 85 percent ethanol and 15 percent regular gasoline. Go to gmc.com and search E85 for more information about E85 as a fuel alternative. ²When properly equipped, includes weight of vehicle, passengers, cargo and equipment. ³GVWR with Duramax Diesel is 9900 lbs. ⁴Maximum payload capacity includes weight of driver, passengers, optional equipment and cargo. ⁵Not available with diesel engine. ⁶Maximum trailer weight ratings are calculated assuming a base vehicle, except for any option(s) necessary to achieve the rating, plus driver. The weight of other optional equipment, passengers and cargo will reduce the maximum trailer weight your vehicle can tow. See your GMC dealer for additional details. ⁷Cargo and load capacity limited by weight and distribution. ⁸Available with Pro Package or driver-side left-hand door.

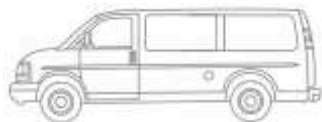

1500 | 135" WB⁸ | RWD | AWD

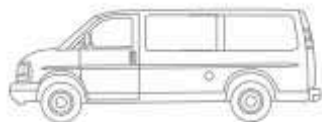

2500 | 135" WB⁸ | RWD

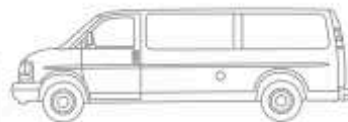

2500 | 155" WB | RWD

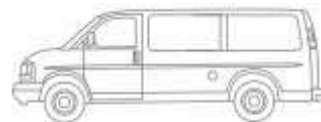

3500 | 135" WB⁸ | RWD

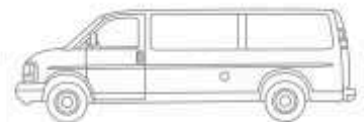

3500 | 155" WB | RWD

SAVANA CUTAWAY VAN SPECIFICATIONS

GMC.COM

S = Standard A = Available - = Not Available

Wheelbase			139"	159"	177"
ENGINE AVAILABILITY	SAE NET HP @ RPM	TORQUE (LB-FT) @ RPM			
Vortec 4.8L V-8 (GVWR < 10,000 lbs)	280 @ 5200	295 @ 4600	S	A	-
Vortec 4.8L V-8 (GVWR > 10,000 lbs)	260 @ 4800	295 @ 4800	S	S	A
Vortec 5.0L FlexFuel ¹ V-8	324 @ 4700	373 @ 4400	A	S	S
Duramax Diesel 6.6L V-8	260 @ 3100	525 @ 1600	A	A	A
TRANSMISSION					
6-Speed 6D Automatic			S	S	S
CAPACITY					
GVWR (lbs) ²			9900-12,300	10,050-14,200	12,300
Front GAWR (lbs)			4100-4800	4100-4800	4600
Rear GAWR (lbs)			6084-8600	7500-8600	8600
Base Payload (lbs) ³			4557-7307	4324-8156	6515-7242

¹See your dealer for E85 availability. E85 is a blend of 85 percent ethanol and 15 percent regular gasoline. Go to gmc.com and search E85 for more information about E85 as a fuel alternative. ²When properly equipped, includes weight of vehicle, passengers, cargo and equipment. ³Maximum payload capacity includes weight of driver, passengers, optional equipment and cargo.

3500 SERIES CUTAWAY

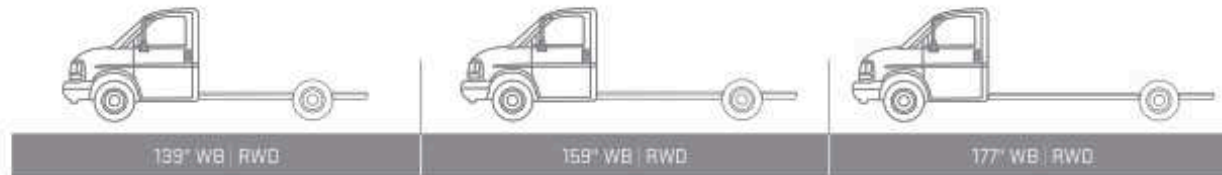

4500 SERIES CUTAWAY

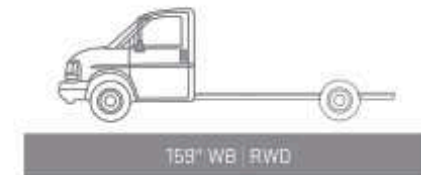



SAVANA PRO CARGO VAN IN SUMMIT WHITE shown with available equipment.



YUKON, YUKON XL, YUKON DENALI AND YUKON XL DENALI

HIGHLIGHTS

- GMC Yukon has better fuel economy than any other competitor.¹
- Yukon and Yukon XL have available seating for up to nine.
- Yukon XL has the most cargo capacity in its class behind the first-, second- and third-row seats.²
- Yukon Denali has best-in-class horsepower.³

¹EPA-estimated 15 city/21 hwy mpg. Based on 2012 GM Large Utility segment. Excludes other GM vehicles. ²Cargo and load capacity limited by weight and distribution.

³Based on 2012 GM Large Utility segment. Excludes other GM vehicles.



YUKON

GMC.COM

YUKON: COMMANDING PRESENCE. IMPECCABLE PERFORMANCE. We build GMC Yukon and Yukon XL for people like you who demand a higher level of comfort and quality. No vehicle in our lineup exemplifies this more than Yukon Denali. Starting with the signature grille, every detail of Yukon Denali and Yukon XL Denali gives the driver and passengers unmatched comfort and luxury. You can count on Yukon to carry up to nine adults and still have exceptional cargo volume. It also has serious towing capability, with Yukon rated up to 8500 lbs and Yukon XL up to 9600 lbs.⁶ Yukon's confident ride and handling are derived from a rigid frame, standard rack-and-pinion steering, standard coil-over-shock front suspension and StabilTrak with traction control.

*Maximum trailer weight ratings are calculated assuming a base vehicle, except for any option(s) necessary to achieve the rating, plus driver. The weight of other optional equipment, passengers and cargo will reduce the maximum trailer weight your vehicle can tow. See your GMC dealer for additional details.



YUKON



YUKON XL



PREMIUM INTERIOR Amenities and comfort features such as dual-zone climate control and a family of audio systems abound inside Yukon and Yukon XL.

20 IMPRESSIVE SPACE Yukon XL and Yukon XL Denali offer the most cargo room in their class behind the first-, second- and third-row seats. Yukon XL's 137.4 cu. ft. of maximum cargo capacity⁶ is perfect for hauling work gear.

⁶Cargo and load capacity limited by weight and distribution.

YUKON XL 3/4-TON Provides a best-in-class maximum trailer weight rating of 9600 lbs.⁶

⁶Maximum trailer weight ratings are calculated assuming a base vehicle, except for any option(s) necessary to achieve the rating, plus driver. The weight of other optional equipment, passengers and cargo will reduce the maximum trailer weight your vehicle can tow. See your GMC dealer for additional details.

21 POWER RELEASE FOLD-AND-TUMBLE SECOND-ROW SEATING A class-exclusive feature to GM vehicles, power release fold-and-tumble seats are available for the

second-row bench or captain's chairs. Each seat automatically unlatches, folds and tumbles out of the way with simple one-hand operation for easy access to the third row. (Not available on SLE or Hybrid models.)

YUKON MOBILE OFFICE Turn your Yukon into a mobile hotspot. The available dealer-installed Autonet WiFi⁷ provides Internet connectivity. See page 39 for more details.

⁷Monthly rates apply. Visit autonetmobile.com for coverage map and details.

YUKON XL DENALI IN ONYX BLACK shown with available equipment.

ACADIA

GMC.COM

ACADIA CAN ADAPT WITH YOUR NEEDS. In business, versatility is the key to success. That's why we created Acadia to provide interior cargo capacity similar to a full-size SUV, while still offering the benefits of a crossover-like ease of entry and exceptional gas mileage. Acadia's spacious interior is easily configured with just one hand, allowing you to strike your preferred balance between seating eight passengers and utilizing the 116.1 cu. ft. of cargo space.¹ Body-frame integral design provides both a low lift-over height to access Acadia's cargo capacity and easy entry and exit for all passengers. The 3.6L Spark Ignited Direct Injection (SIDI) VVT engine offers an impressive 288 hp and 270 lb-ft of torque in addition to a one-tank highway driving range of up to 528 miles.²

¹Cargo and load capacity limited by weight and distribution. ²Based on EPA-estimated [2WD] 24 hwy mpg and fuel tank capacity. Your range may be less.

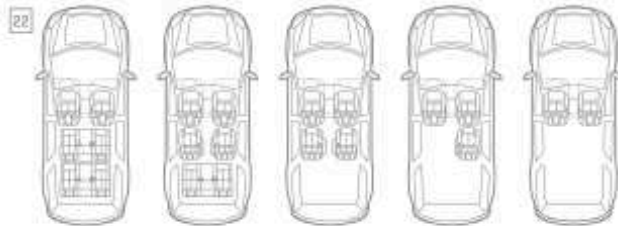

22 Acadia's highly configurable interior helps balance your passenger and cargo needs. You can fold the second and third rows to create a flat area for convenient loading capability.



MOBILE OFFICE Available Autonet WiFi,³ available IntelliLink,⁴ Bluetooth⁵ for phone connectivity and available three-prong 120-volt power outlet turn Acadia into a fully functional mobile office, allowing employees to work from nearly anywhere.

³Monthly rates apply. Visit autonetmobile.com for coverage, map and details. ⁴Full functionality requires compatible Bluetooth and smartphone. Some devices require USB connectivity. ⁵Go to gmc.com/bluetooth to find out which Bluetooth phones are compatible with the vehicle.

23 INTELLILINK⁵ The available IntelliLink system provides smartphone integration and voice-activated control of your communication and entertainment selections, streaming Internet radio stations Pandora[®] and Stitcher[™] SmartRadio through your

smartphone or accessing your iPod[®] music library.

⁶Full functionality requires compatible Bluetooth and smartphone. Some devices require USB connectivity. Data plan rates apply.

COLOR TOUCH NAVIGATION⁷ The available NAV system adds more than just navigation to the Color Touch Radio. Multiple map views, weather updates and traffic alerts are also at your fingertips with the touch of an icon on the home screen. It also features a 3-month trial of NavTraffic⁸ and Local Forecast feature (in areas with this broadcast capability).

⁷Map coverage available in the United States, U.S. Virgin Islands, Puerto Rico and Canada. ⁸If you subscribe after your trial period, subscriptions are continuous until you call SiriusXM to cancel. See SiriusXM Customer Agreement for complete terms.

at siriusxm.com. Other fees and taxes will apply. All fees and programming subject to change. For more information about NavTraffic, visit siriusxm.com/navtraffic.

24 SMART SLIDE SEATING Makes the third-row entry and exit easier for people of many sizes. Acadia's Smart Slide second-row seating slides the seats to the forward-most position, and then compacts them for space with the same folding action you would use for a chaise lounge. The Smart Slide feature operates with just one lever and one hand.



ACADIA

HIGHLIGHTS

- Acadia provides the cargo capacity of a full-size SUV with the fuel economy of a midsize SUV.¹
- No competitor offers more cargo volume behind the third row.¹¹
- Seating for up to eight.
- Convenient one-hand operation for flat-folding second- and third-row seats.
- Available Tri-Zone Climate Control System that accommodates third-row passengers.

¹EPA-estimated mpg [2WD] 21 city/24 hwy and [AWD] 20 city/23 hwy. ¹¹Cargo and load capacity limited by weight and distribution.





ACADIA SLT IN CRYSTAL RED TINTODAT shown with available equipment.



TERRAIN

MOBILE WORKSPACE FOR A MOBILE WORKFORCE. We know how high-tech solutions can boost the productivity of your business. Make Terrain part of your fleet and you'll reap the benefits of a technology-laden crossover. Available communication technologies include IntelliLink¹ and OnStar² (6 months standard) that allow your workforce to stay in touch. Intelligent safety technologies like the available Forward Collision Alert and Lane Departure Warning make navigating any environment safer. Smart engineering results in head room and leg room rivaling that of a full-size SUV while still providing an EPA-estimated 32 mpg on the highway. Innovative MultiFlex seating lets you configure the interior to choose between Terrain's client- and customer-pleasing 39.5 inches of second-row leg room or 31.6 cu. ft. of cargo³ space behind the second row, making it a flexible and comfortable option for your fleet.

¹Full functionality requires compatible Bluetooth and smartphone. Some devices require USB connectivity. ²Visit onstar.com for coverage map, details and system limitations. ³Cargo and load capacity limited by weight and distribution.



COLOR TOUCH RADIO SYSTEM This standard entertainment system makes your Terrain an even more integral part of your life. It is based on a bold and intuitive 7" high-resolution, full-color touch-screen display that makes it easy to keep your eyes on the road while driving.

MOBILE OFFICE Stay in touch and productive no matter where the workday takes you. Dealer-installed Autonet WiFi⁴ provides Internet connectivity, turning your Terrain into a mobile hotspot.

⁴Monthly rates apply. Visit autonetmobile.com for coverage map and details.

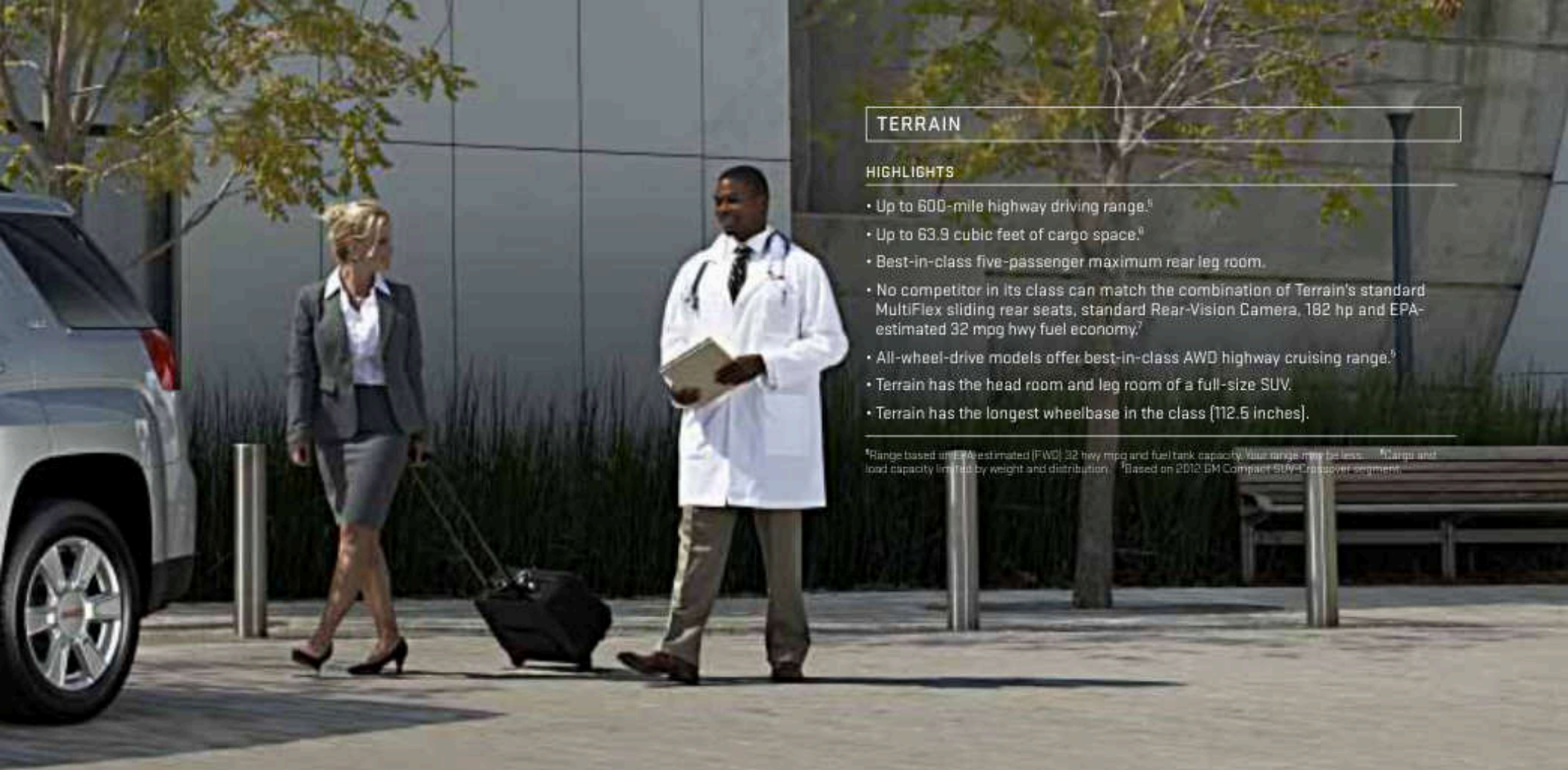

TERRAIN

HIGHLIGHTS

- Up to 600-mile highway driving range.¹
- Up to 63.9 cubic feet of cargo space.²
- Best-in-class five-passenger maximum rear leg room.
- No competitor in its class can match the combination of Terrain's standard MultiFlex sliding rear seats, standard Rear-Vision Camera, 182 hp and EPA-estimated 32 mpg hwy fuel economy.³
- All-wheel-drive models offer best-in-class AWD highway cruising range.⁴
- Terrain has the head room and leg room of a full-size SUV.
- Terrain has the longest wheelbase in the class (112.5 inches).

¹Range based on EPA-estimated (FWD) 32 hwy mpg and fuel tank capacity. Your range may be less. ²Cargo and load capacity limited by weight and distribution. ³Based on 2012 GM Compact SUV/Crossover segment. ⁴Cargo and load capacity limited by weight and distribution.

TERRAIN SLT-1 IN QUICKSILVER METALLIC shown with available equipment.*

GMC.COM



25 INTELLILINK® Available IntelliLink uses Bluetooth® or USB¹ to connect the driver's smartphone to Terrain's 7" Color Touch Radio. It allows for voice activation and hands-free calling and has steering-wheel-mounted controls to operate your smartphone.

¹Full functionality requires compatible Bluetooth and smartphone. Some devices require USB connectivity. ²Go to gm.com/bluetooth to see list of which Bluetooth phones are compatible with the vehicle. ³Not compatible with all devices.

COLOR TOUCH NAVIGATION® The available NAV system adds more than just navigation to the Color Touch Radio. Multiple map views, weather updates and traffic alerts are also at your fingertips with the touch of an icon on the home screen. It also features a 3-month trial of NavTraffic™ and Local Forecast feature (in areas with this broadcast capability).

¹Map coverage available in the United States, U.S. Virgin Islands, Puerto Rico and Canada. ²90 days, 300 miles after your trial period ends. ³Where we continue until you call GMCNAV to cancel. See GMCNAV Customer Agreement for complete terms at gmcnav.com. Other fees and taxes will apply. All fees and programming subject to change. For more information about NavTraffic™, visit gmcnav.com/navtraffic. XM satellite service is available only to those in the 48 contiguous USA states.

26 ROOM FOR EVERYTHING--AND EVERYONE Terrain complements its generous space for passengers with smart storage solutions to help you make the most of your cargo space.

MULTIFLEX SEATING. MultiFlex second-row seats easily slide back to enhance leg room, or slide forward for more cargo room.

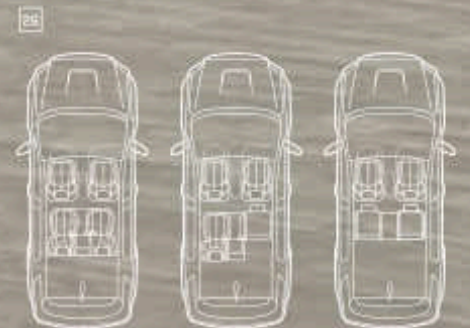

YUKON SPECIFICATIONS

GMC.COM

S = Standard A = Available -- Not Available

ENGINE AVAILABILITY	SAE NET HP @ RPM	TORQUE [LB-FT] @ RPM	YUKON		YUKON HYBRID		YUKON XL 1500		YUKON XL 2500		YUKON DENALI		YUKON DENALI HYBRID		YUKON XL DENALI	
			2WD	4WD	2WD	4WD	2WD	4WD	2WD	4WD	2WD	4WD	2WD	4WD	2WD	4WD
Vortec 5.3L V-8	320 @ 5400	335 @ 4000	S	S	-	-	S	S	-	-	-	-	-	-	-	-
Vortec 6.0L V-8 Hybrid [364 cu. in.]	332 @ 5100	367 @ 4100	-	-	S	S	-	-	-	-	-	-	S	S	-	-
Vortec 6.0L V-8 HD [364 cu. in.]	352 @ 5400	382 @ 4200	-	-	-	-	-	-	S	S	-	-	-	-	-	-
Vortec 6.2L V-8 [376 cu. in.]	403 @ 5700	417 @ 4300	-	-	-	-	-	-	-	-	S	S	-	-	S	S
TRANSMISSION																
6-Speed Automatic			S	S	-	-	S	S	-	-	S	S	-	-	S	S
6-Speed Heavy-Duty OD Automatic			-	-	-	-	-	-	S	S	-	-	-	-	-	-
4-Speed OD Automatic Hybrid			-	-	S	S	-	-	-	-	-	-	S	S	-	-
AXLE RATIO																
3.08:1			S	S	S	S	S	S	-	-	-	-	S	S	-	-
3.42:1			A	A	-	-	A	A	-	-	S	S	-	-	S	S
3.73:1			-	-	-	-	-	-	S	S	-	-	-	-	-	-
CAPACITY																
GVWR (lbs)*			7100	7300	7100	7300	7200	7400	8600	8800	7100	7300	7300	7500	7200	7400
Front GAWR (lbs)			3200	3600	3400	3600	3500	3600	3800	4180	3250	3550	3400	3600	3500	3600
Rear GAWR (lbs)			4100	4200	4100	4100	4200	4200	5500	5500	4200	4200	4100	4100	4200	4200
Payload (lbs)†			1633	1606	1444	1344	1526	1580	2459	2187	1609	1615	1411	1397	1461	1463
MAX TRAILERING																
Engine			Vortec 5.3L	Vortec 5.3L	Vortec 6.0L Hybrid	Vortec 6.0L Hybrid	Vortec 5.3L	Vortec 5.3L	Vortec 6.0L	Vortec 6.0L	Vortec 6.2L	Vortec 6.2L	Vortec 6.0L Hybrid	Vortec 6.0L Hybrid	Vortec 6.2L	Vortec 6.2L
Axle Ratio (2WD/4WD)			3.42	3.42	3.08	3.08	3.42	3.42	3.73	3.73	3.42	3.42	3.08	3.08	3.42	3.42
Maximum Trailer Weight*‡			6500	6200	6200	5900	6100	8000	9600	9400	8300	8100	6000	5700	7900	7800
DIMENSIONS																
			YUKON		YUKON HYBRID		YUKON XL		YUKON XL 2500		YUKON DENALI		YUKON DENALI HYBRID		YUKON XL DENALI	
Wheelbase (in.)			116.0		116.0		130.0		130.0		116.0		116.0		130.0	
Overall Length (in.)			202.0		202.0		222.4		222.4		202.0		202.0		222.4	
Overall Height (in.)			76.9		76.9		76.8		76.8		76.9		76.9		76.8	
Overall Width (in.)			78.0		79.0		79.1		79.1		79.0		79.0		79.1	
Fuel Tank Capacity (in Gallons (approx.))			26.0		25.0		31.0		39.0		26.0		25.0		31.0	
Standard Wheels (in.)			17		18		17		17		20		22		20	

*Available at participating dealers. †When properly equipped, includes weight of vehicle, passengers, cargo and equipment. ‡Maximum payload capacity includes weight of driver, passengers, optional equipment and cargo. †Maximum trailer weight ratings are calculated assuming a base vehicle, except for any option(s) necessary to achieve the rating, plus driver. The weight of other optional equipment, passengers and cargo will reduce the maximum trailer weight your vehicle can tow. See your GMC dealer for additional details.

YUKON/DENALI

YUKON XL/YUKON XL DENALI



2WD | 2WD

4WD | 4WD

ACADIA AND TERRAIN SPECIFICATIONS

GMC.COM

S = Standard A = Available -- = Not Available

ACADIA/ACADIA DENALI

ENGINE AVAILABILITY	SAE NET HP @ RPM	TORQUE (LB-FT) @ RPM	FWD	AWD
3.6L V-6 SIDI VVT	288 @ 6300	270 @ 3400	S	S
TRANSMISSION				
6-Speed Automatic, Electronically Controlled with OD			S	S
AXLE RATIO				
3.36:1			S	S
CAPACITY				
GVMR (lbs) ²			6411	6459
Payload (lbs) ²			1415-1755	1250-1609
MAX TRAILERING				
Engine			3.6L V-6 SIDI VVT	3.6L V-6 SIDI VVT
Axle Ratio			3.16	3.16
Maximum Trailer Weight ³			5200	5200
DIMENSIONS				
Wheelbase (in.)			118.5	118.5
Overall Length (in.)			200.8	200.8
Overall Height (in.) Without Luggage Rack			70.4	70.4
Overall Width (in.)			78.9	78.9
Fuel Tank Capacity in Gallons (approx.)			22.0	22.0
Standard Wheels (in.)			18	18
Head Room (first row) (in.)			40.3	40.3
Leg Room (first row) (in.)			41.3	41.3
Shoulder Room (first row) (in.)			51.6	51.5
Hip Room (first row) (in.)			58.0	58.0
Cargo Volume Behind First Row (cu. ft.) ⁴			116.1	116.1
Cargo Volume Behind Second Row (cu. ft.) ⁴			70.1	70.1
Cargo Volume Behind Third Row (cu. ft.) ⁴			24.1	24.1

¹When properly equipped, includes weight of vehicle, passengers, cargo and equipment. ²Maximum payload capacity includes weight of driver, passengers, optional equipment and cargo. ³Maximum trailer weight ratings are calculated assuming a base vehicle, except for any option(s) necessary to achieve the rating, plus driver. The weight of other optional equipment, passengers and cargo will reduce the maximum trailer weight your vehicle can tow. See your GMC dealer for additional details. ⁴Cargo and load capacity limited by weight and distribution.

ACADIA



FWD | AWD

S = Standard A = Available -- = Not Available

TERRAIN

TERRAIN DENALI

ENGINE AVAILABILITY	SAE NET HP @ RPM	TORQUE (LB-FT) @ RPM	FWD	AWD	FWD	AWD
2.4L I-4 SIDI	182 @ 6700	172 @ 4900	S	S	S	S
3.6L V-6 SIDI	301 @ 6500	272 @ 4600	A	A	A	A
TRANSMISSION						
6-Speed OD Automatic			S	S	S	S
AXLE RATIO						
2.77:1			A	--	A	--
3.23:1			S	--	S	--
3.39:1			--	A ¹	--	A
3.53:1			--	S	--	S
CAPACITY						
Engine			2.4L I-4/3.6L V-6	2.4L I-4/3.6L V-6	2.4L I-4/3.6L V-6	2.4L I-4/3.6L V-6
Drivetrain			FWD	AWD	FWD	AWD
GVMR (lbs) ²			4960/5200	5070/5300	4960/5200	5070/5300
Front GAWR (lbs)			2580/2755	2580/2755	2590/2755	2590/2755
Rear GAWR (lbs)			2733/2733	2733/2821	2733/2733	2733/2821
Base Payload (lbs) ²			1107/1168	1050/1162	1079/1154	1021/1096
MAX TRAILERING						
Engine			2.4L I-4/3.6L V-6	2.4L I-4/3.6L V-6	2.4L I-4/3.6L V-6	2.4L I-4/3.6L V-6
Axle Ratio			3.23/2.77	3.53/3.39	3.23/2.77	3.53/3.39
Maximum Trailer Weight ³			1500/3500	1500/3500	1500/3500	1500/3500
DIMENSIONS						
Wheelbase (in.)			112.5	112.5	112.5	112.5
Overall Length (in.)			185.3	185.3	185.3	185.3
Overall Height (in.) Without Luggage Rack			66.3	66.3	66.3	66.3
Overall Width (in.)			72.8	72.8	72.8	72.8
Fuel Tank Capacity in Gallons (I-4/V-6) (approx.)			18.8/20.9	18.8/20.9	18.8/20.9	18.8/20.9
Head Room (first row) (in.)			39.8	39.8	39.8	39.8
Leg Room (first row) (in.)			41.2	41.2	41.2	41.2
Shoulder Room (first row) (in.)			55.7	55.7	55.7	55.7
Hip Room (first row) (in.)			55.1	55.1	55.1	55.1
Cargo Volume Behind First Row (cu. ft.) ⁴			63.9	63.9	63.9	63.9
Cargo Volume Behind Second Row (cu. ft.) ⁴			31.6	31.6	31.6	31.6

¹AWD models with 18" wheels only. Axle ratio on V-6 AWD models with 18" wheels is 3.39. ²When properly equipped, includes weight of vehicle, passengers, cargo and equipment. ³Maximum payload capacity includes weight of driver, passengers, optional equipment and cargo. ⁴Maximum trailer weight ratings are calculated assuming a base vehicle, except for any option(s) necessary to achieve the rating, plus driver. The weight of other optional equipment, passengers and cargo will reduce the maximum trailer weight your vehicle can tow. See your GMC dealer for additional details. ⁵Cargo and load capacity limited by weight and distribution.

TERRAIN

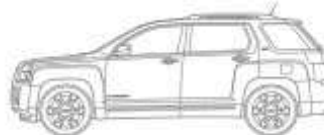

FWD | AWD



SAVANA 2500 CARGO VAN IN SUMMIT WHITE shown with available equipment.

ALTERNATIVE FUELS

GMC.COM

AN ALTERNATIVE FUEL COULD BE RIGHT FOR YOU. Whether you need to meet company-wide environmental initiatives or government standards, GMC offers a choice of alternative fuels for Savana and Sierra HD. Savana's CNG and LPG systems are designed for both low emissions and low operating costs. Sierra 2500HD can be equipped with our new CNG/Gasoline Bi-Fuel System, helping your organization reduce costs and environmental impact.

ALTERNATIVE FUELS AVAILABILITY (see your dealer for more details)

VEHICLE	CNG	LPG	E85 ¹	B20	BI-FUEL
Sierra	A	-	A	A	A
Savana	A	A	A	A	-
Yukon	-	-	A	-	-
Acadia	-	-	-	-	-
Terrain	-	-	A ²	-	-

A = Available - = Not Available

¹E85 is a blend of 85 percent ethanol and 15 percent regular gasoline. Visit gmc.com and search E85 for more information about E85 as a fuel alternative. ²Only available in federal emissions states.



CNG/LPG Dedicated CNG and LPG fuel systems are available on the Savana Cargo and Savana Cutaway models, respectively. CNG and LPG vehicles are equipped with a specially designed 6.0L Vortec engine built for gaseous fuel, along with an integrated and warranted dedicated gaseous fuel system in place.

BI-FUEL GAS/CNG SYSTEM Our proven 6.0L Vortec V-8 forms the core of Sierra 2500HD's CNG/Gasoline Bi-Fuel System. Enhanced with hardened exhaust valves and intake/exhaust seats, an in-bed CNG tank and an extensively protected fuel system, the Bi-Fuel System provides a driving range of 650-plus miles³ while still offering up to 2948 lbs of payload capacity⁴—helping businesses reduce costs and environmental impact. GMC's limited warranty covers the CNG fuel delivery and

storage system, providing you with peace of mind that parts will be available to keep you on the road.

³Based on GM testing and fuel tank capacity. Your range may be less. ⁴Maximum payload capacity includes weight of driver, passengers, optional equipment and cargo.

3- OR 4-TANK SYSTEM CNG-equipped Savanas can be outfitted with either a 3-tank or an extended range 4-tank system. Both systems are designed to maximize fuel mileage while minimizing abrasion in the cargo area. LPG models come equipped with 3-tank systems only.



YUKON HYBRID IN QUICKSILVER METALLIC shown with available equipment.
SIERRA HYBRID CREW CAB IN QUICKSILVER METALLIC shown with available equipment.

HYBRID VEHICLES

GMC.COM

ENGINEERING LEADERSHIP. GMC created the first family of full-size hybrids. Both Sierra and Yukon can be equipped with an innovative hybrid powertrain that combines the benefits of electric power with those of traditional gas engines. This combination allows Sierra Hybrid and Yukon Hybrid to offer best-in-class fuel economy while retaining full-size pickup and SUV capability. Available at select GMC dealers.

HYBRIDS

SIERRA AND YUKON HYBRIDS

ENGINE:	Vortec 6.0L VVT Hybrid
HP @ RPM:	332 @ 6100
LB-FT TORQUE @ RPM:	367 @ 4100

HIGHLIGHTS

- GMC offers the first full-size family of hybrids.
- The 2013 Sierra and Yukon Hybrids have best-in-class V-8 fuel economy.
- Multiple fuel-saving technologies work together to make the Sierra and Yukon Hybrids the most advanced full-size pickup and SUV available today.



28 HYBRID POWERTRAIN The Two-Mode Hybrid System saves fuel with an all-electric launch, low-speed electric-only propulsion and electric assist during demanding driving. It is comprised of a Vortec 6.0L VVT V-8 engine, two 60-kilowatt electric motors housed within the transmission that also act as generators, a 300-volt battery that powers the system and an innovative regenerative braking system that results in an EPA-estimated 20 mpg city/23 mpg highway for both Sierra and Yukon.

REGENERATIVE BRAKING Each time you apply the brakes, the Hybrid system captures kinetic energy and converts it to electrical energy to recharge the battery pack. This technology—called regenerative braking—helps maintain the battery's charge.

29 HYBRID POWER FLOW DISPLAY By selecting "Hybrid" on your navigation touch-screen (available on Sierra), you can see the power flows of the two modes in action. Mode 1: Used at low speeds and with light loads, running under electric power, gas power or both at once. Mode 2 (shown): At higher speeds, the gas engine engages for the V-8 power and capability you expect. Even at highway speeds, GMC's Active Fuel Management works to help these vehicles maximize fuel efficiency.

FEATURES & TECHNOLOGY

GMC.COM

Our engineers continue to improve the fuel efficiency, trailering capability and raw power of our entire product line. In fact, we offer you class-leading highway fuel mileage (Sierra and Yukon),¹ cargo space (Yukon XL and Acadia)² and trailering capacities (Yukon XL ¾-ton, Sierra 2500HD ¾-ton fifth-wheel and 3500HD 1-ton fifth-wheel) that stand out on any spreadsheet. It's a testament to our no-compromises approach to engineering that allows every GMC to excel in the work it was designed to do. That's what makes GMC professional grade.

¹Based on EPA-estimated hwy mpg: Sierra XFE, 22 hwy mpg; Sierra Hybrid, 23 hwy mpg; Yukon with 5.3L V-8 engine, 21 hwy mpg; Yukon Hybrid and Yukon Small Hybrid, 23 hwy mpg. ²Acadia cargo volume behind the front row. Cargo and load capacity limited by weight and distribution.



30 EATON® HEAVY-DUTY AUTOMATIC LOCKING REAR DIFFERENTIAL When the Eaton locker senses the difference in rotational speed between left and right wheels of approximately 100 rpm, it locks the differential to turn both wheels in unison for added traction. Standard on Yukon and available on Sierra and Savana, no other competitors in their class offer this automatic locking rear differential for on- or off-road use.

STABILITRAK Standard on most GMC models, StabiliTrak incorporates sensors that read the position of your steering wheel, vehicle speed, brake pressure, lateral acceleration and turning rate, then feed the data to an onboard computer. If your vehicle is not responding adequately to your steering input, the computer instantly adjusts engine speed and brake pressure to any individual wheel to help keep you on track.



31 TRAILERING Our engineers have devised technologies designed to make trailering easier. Depending on which model you're looking at, you could have Trailer Sway Control, a trailer brake controller or a choice of suspensions so drivers can tow confidently and safely.

OIL LIFE MONITOR For long life and durability, changing your engine oil at the right time is essential. GMC engineered the mystery out of this essential service with the Oil Life Monitor. It calculates how much life your oil has left, based on when and how you drive, and updates you on your Driver Information Center. See your dealer for more details and availability.

CENTER CONSOLES Sierra has extra storage in the center console and an available lockable storage area integrated into the front bench seat. These provide extra storage—ideal for keeping valuable items out of view.



SEATING GMC vehicles are appointed with premium fabrics designed to look good for many years. Innovations in cargo loading and seating configurations mean you can select the precise GMC to suit your needs. Please see specific model pages for more details.

32 REAR-VISION CAMERA SYSTEM Most models can be equipped with a Rear-Vision Camera System, which displays the view behind your vehicle either on the rearview mirror or an available 7" center screen.

ALTERNATIVE FUELS GMC offers numerous fuel options for powering your fleet. In addition to E85³ gasoline and B20 diesel fuels, select vehicles offer fuel systems that run on compressed natural gas (CNG) or liquefied propane gas (LPG). See page 36 for details.

³E85 is a blend of 85 percent ethanol and 15 percent regular gasoline. Visit gmc.com and search E85 for more information on E85 as a fuel alternative.

MOBILE OFFICE TECHNOLOGIES

GMC.COM

A company vehicle is often the linchpin of an entire enterprise. That's why we offer a range of advanced mobile office technologies that can transform the productivity of the service and support personnel you put behind the wheel and on the road. Available features like IntelliLink,⁴ Bluetooth,⁵ Touch-Screen Navigation⁶ systems and dealer-installed Autonet WiFi⁷ help turn your new GMC into an instantly responsive mobile field office.

⁴Full functionality requires compatible Bluetooth and smartphone. Some devices require USB connectivity. Data plan rates apply. ⁵Go to gmc.com/bluetooth to find out which Bluetooth phones are compatible with the vehicle. ⁶Map coverage available in the United States, U.S. Virgin Islands, Puerto Rico and Canada. ⁷Monthly rates apply. Visit autonetmobile.com for coverage map and details.

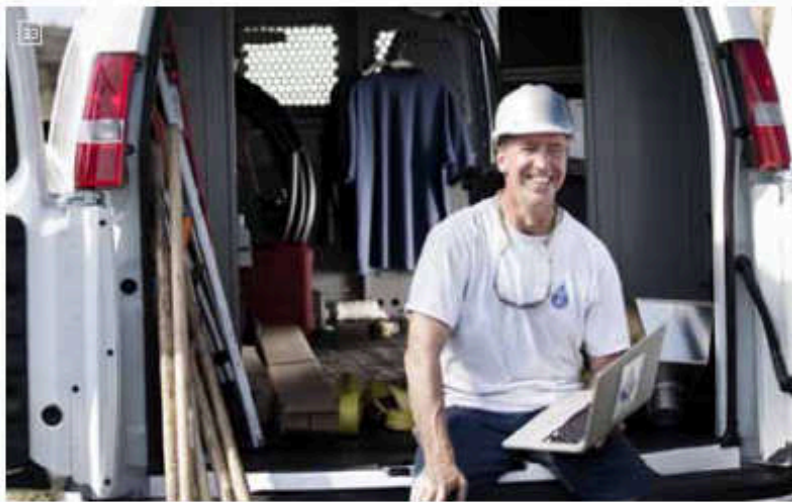

33 AUTONET WiFi⁷ This available dealer-installed feature instantly turns your GMC into a WiFi hotspot, allowing you to connect WiFi-enabled devices within 150 feet of the vehicle. Add FleetTracker to gain a powerful set of services that cut costs, improve productivity and increase driver safety. Affordably track the location of drivers, assets and various other equipment via a Web portal. Track your employees' productivity through GeoFencing and mobile time card functionality that allows you to monitor hard-dollar costs of field workers. Increase driver safety by setting alerts for speeding conditions and preventative maintenance tasks. Find out more information at autonetmobile.com.

⁷Monthly rates apply. Visit autonetmobile.com for coverage map and details.

34 ONSTAR⁸ Both an advanced technology fully integrated into the vehicle and a human service, OnStar is available to act as a link to information and emergency services. Subscribe to OnStar and receive access to OnStar Directions & Connections Plan, Hands-Free Calling,⁹ Automatic Crash Response and other services that help keep your fleet operating safely and efficiently regardless of location.

⁸Visit onstar.com for coverage map, details and system limitations. OnStar acts as a link to emergency service providers. ⁹OnStar Hands-Free Calling requires a Hands-Free Calling enabled vehicle, existing OnStar service contract and prepaid minutes. Not available in certain markets. Calls can be made in U.S. and Canada only.

35 TOUCH-SCREEN NAV SYSTEMS⁶ Available touch-screen and voice-activated navigation systems in Savana, Sierra and Yukon (touch-activated only on Terrain and Acadia) help your crew get to the jobsite without getting lost. Subscribe to SiriusXM NavTraffic¹⁰ to integrate traffic information into travel routes so you can reduce travel times.

⁶Map coverage available in the United States, U.S. Virgin Islands, Puerto Rico and Canada. ¹⁰If you subscribe after your trial period, subscriptions are continuous until you call SiriusXM to cancel. See SiriusXM Customer Agreement for complete terms at siriusxm.com. Other fees and taxes will apply. All fees and programming subject to change. For more information about NavTraffic, visit siriusxm.com/navtraffic. XM satellite service is only available to those in the 48 contiguous USA and DC.

36 BLUETOOTH⁵ Available Bluetooth for phone connectivity allows you to stay in contact with your crew, clients or home office without sacrificing safety. Once your Bluetooth-enabled phone is paired with a properly equipped GMC, you can use interior controls and features to place calls hands-free.

⁵Go to gmc.com/bluetooth to find out which Bluetooth phones are compatible with the vehicle.

GMC ACCESSORIES

GMC.COM

CARGO CAPABILITIES AND ACCESSORIES THAT HANDLE YOUR NEEDS. Customize your professional-grade GMC to fit your business needs. Every one of our accessories lives up to the GMC name and helps you take on the challenges of your business.



GMC BUSINESS CHOICE

GMC Business Choice is an incentive program designed specifically for business owners who use vehicles in the day-to-day operation of their business and not solely for transportation purposes. This incentive is available when you purchase or lease an eligible truck or van and offers valuable upfit equipment. See your GMC dealer for details.



GMC BUSINESS CHOICE

IMPORTANT WORDS ABOUT THIS CATALOG

GMC'S COMMITMENT GMC is committed to offering your business a hassle-free trucking experience that includes a **limited warranty** and a strong network of **GMC dealers** who are ready to answer your questions, provide authorized service, maintain a large stock of Genuine GM Parts and accessories and give you access to GMC factory personnel. For help and information, call **1-800-GMC-8782**.

We have tried to make this catalog comprehensive and factual. We reserve the right, however, to make changes at any time, without notice, in prices, colors, materials, equipment, specifications, models and availability. **Specifications, dimensions, measurements, ratings and other numbers in this catalog and other printed materials provided at the dealership or affixed to vehicles are approximates based upon design and engineering drawings, prototypes and laboratory tests. Your vehicle may differ due to variations in manufacturer and equipment.** Since some information may have been updated since the time of printing, please check with your GMC dealer for complete details. GMC reserves the right to lengthen or shorten the model year for any product for any reason or to start and end model years at different times.

CORROSION PROTECTION GMC vehicles are designed and built to resist corrosion. All body and sheet metal components are warranted against rust-through corrosion for 6 years/100,000 miles (whichever comes first). Application of additional rust-inhibiting materials is not required under the corrosion coverage and none is recommended. See your GMC dealer for terms of this limited warranty.

AN IMPORTANT NOTE ABOUT ALTERATIONS AND WARRANTIES Installations or alterations to the original-equipment vehicle (or chassis) as distributed by General Motors are not covered by the General Motors New-Vehicle Limited Warranty. The special body company, assembler, equipment installer or upfitter is solely responsible for warranties on the body or equipment and any alterations (or any effect of the alterations) to any of the parts, components, systems or assemblies installed by GM. General Motors is not responsible for the safety or quality of design features, materials or workmanship of any alterations by such supplier.

UPDATED SERVICE INFORMATION GMC dealers receive useful service bulletins about GMC products. You may purchase them from Helm Incorporated by calling 1-800-551-4123 or by visiting helminc.com.

ASSEMBLY GMC vehicles and their components are assembled or produced by different operating units of General Motors, its subsidiaries or suppliers to GM worldwide. We sometimes find it necessary to produce GMC vehicles with different or differently sourced components than originally scheduled. Since some options may be unavailable when your vehicle is assembled, we suggest you verify that your vehicle includes the equipment you ordered and that, if there were changes, they are acceptable to you.

ENGINES GMC products are equipped with engines produced by GM Powertrain or other suppliers to GM worldwide. The engines in GMC products may also be used in other GM makes and models.

TRAILERING WITH YOUR GMC GMCs are built strong and durable to handle the demands of trailering. Certain equipment needed for trailering is standard: power steering, power brakes, 7-wire trailering harness, a large fuel tank, a 160-amp alternator (125-amp on 1/2-ton Heavy Duty models) and a front stabilizer bar. Also required and available (some items are standard on certain models) are special transmission oil and coolers. For other available trailering-related equipment, talk to your dealer. You'll need a hitch, of course, and a selection of hitch types is available, either as factory-installed equipment, such as an available step bumper, or from your dealer. In addition, if you plan to tow frequently, you should be sure your vehicle is properly equipped. If you have any questions about trailering with a GMC, before you buy feel free to ask your dealer for a copy of the GMC Trailering Guide. Be sure to read it and use it as a guide before you hitch a trailer to your vehicle.

NEW-VEHICLE LIMITED WARRANTY All GMC light-duty vehicles come with a fully backed 5-year/100,000-mile (whichever comes first) transferable Powertrain Limited Warranty with no deductible. GM vehicles registered in the USA are covered for 3 years or 36,000 miles (whichever comes first). See your dealer for more details. The complete vehicle is covered, including tires, towing to your nearest GMC dealership and cosmetic corrosion resulting from defects. Repairs will be made to correct any vehicle defect, and most warranty repairs will be made at no charge. In addition, rust-through corrosion will be covered for 6 years or 100,000 miles (whichever comes first). See dealer for details.

A NOTE ON CHILD SAFETY Always use safety belts and the correct child restraint for your child's age and size, even with air bags. Even in vehicles equipped with the Passenger Sensing System, children are safer when properly secured in a rear seat in the appropriate infant, child or booster seat. Never place a rear-facing infant restraint in the front seat of any vehicle equipped with an active frontal air bag. See your vehicle Owner's Manual and child safety seat instructions for more safety information.

IMPORTANT INFORMATION ABOUT ONSTAR OnStar services require vehicle electrical system (including battery), wireless service and GPS satellite signals to be available and operating for features to function properly. OnStar acts as a link to existing emergency service providers. Subscription Service Agreement required. Call 1-888-4-ONSTAR (1-888-466-7827) or visit onstar.com for OnStar's Terms & Conditions, Privacy Statement and details and system limitations. Additional information can be found in the OnStar Owner's Guide.

SIRIUSXM SATELLITE RADIO SiriusXM Satellite Radio¹ is standard on most GMC models. It includes 3 trial months of service. SiriusXM Satellite Radio makes your drive come alive with commercial-free music channels from virtually every genre, artist-dedicated channels, live performances and more. Tune in to live play-by-play from the biggest sports, exclusive entertainment from top personalities, compelling talk, hilarious comedy, world-class news, local traffic and weather and family-friendly programming. Welcome to the world of satellite radio. Visit siriusxm.com for details.

THE GM CARD What are you charging toward? The GM Card rewards you 3 percent on every credit card purchase, making it the fastest way to save toward the GM car or truck of your dreams. For information or to apply for the GM Card, call 1-800-8GM-CARD or visit our Web site at gmcards.com.

GM PROTECTION PLAN The GM Protection Plan is the only vehicle service and maintenance contract endorsed by General Motors. The GM Protection Plan offers mechanical coverage for the parts and labor costs of repairing covered vehicle components against failure—even if it results from wear and tear (except in Kentucky). Depending on the level of coverage, additional benefits may include Roadside Assistance, alternate transportation or towing. The GM Protection Plan also offers basic maintenance coverage for specific maintenance needs. Ask your dealer about the GM Protection Plan, or visit gmprotectionplan.com for coverage information and details.

¹If you subscribe after your trial period, subscriptions are continuous until you call SiriusXM to cancel. See SiriusXM Customer Agreement for complete terms at siriusxm.com. Other fees and taxes will apply. All fees and programming subject to change. For more information about NavTraffic, visit siriusxm.com/navtraffic. For more information about Travel Link, visit siriusxm.com/travelink. XM satellite service is available only to those in the 48 contiguous USA and DC.

©2012 General Motors. All rights reserved. GM, the GM logo, GMC, the slogans, emblems, vehicle model names, vehicle body designs, and other marks appearing in this catalog are the trademarks and/or service marks of General Motors, its subsidiaries, affiliates or licensors. iPod and iTunes are registered trademarks of Apple, Inc. Facebook is a registered trademark of Facebook, Inc. Twitter is a registered trademark of Twitter, Inc. YouTube is a registered trademark of Google, Inc. Sirius, XM and all related marks and logos are trademarks of SiriusXM Radio, Inc. Adrian Steel is a registered trademark of Adrian Steel Company. For more information on GMC commercial vehicles, see your GMC dealer, call 1-800-GMC-8782 or visit gmc.com.

ADDITIONAL FLEET SERVICES



EXPERIENCE A WHOLE NEW LEVEL OF CONFIDENCE IN GM QUALITY Standard on all 2013 GM cars and light-duty trucks is a 5-year/100,000-mile transferable Powertrain Limited Warranty with no deductible.² You also get 5 years/100,000 miles² of 24/7 roadside assistance, courtesy transportation and much more.

²Whichever comes first. See dealer for limited warranty details.



YOU'RE THE BUSINESS, WE'RE THE DEALERSHIP In the coast-to-coast Business Central network, each dealership is dedicated to helping you find the right vehicles for just about any job. They'll meet with you at almost any time and any place that's convenient for you, even at your place of business. And every Business Central dealership offers service facilities specialized to keep your work vehicles operating at peak performance and efficiency, helping you better serve your customers.

Your Business Central dealership has the widest selection of vehicles to fit your business needs. From the Sierra family of full-size pickups to the full line of Savana Vans. Plus a wide range of work-ready vehicles ready to meet your needs. To find a Business Central dealership near you, go to gmcbusinesscentral.com.



For additional Fleet and Commercial information, visit gmfleet.com.

GMC.COM





VISIT US AT GMC.COM



FACEBOOK.COM/GMC



TWITTER.COM/THISISGMC



YOUTUBE.COM/GMC

136MCL0CRG-26