



COMMERCIAL

2016

CO

GMC WE ARE PROFESSIONAL GRADE



CONTENTS

CANYON | 4

SIERRA 1500 | 6

SIERRA HD | 16

SAVANA | 28

YUKON | 36

ACADIA | 38

TERRAIN | 40

ALTERNATIVE FUELS | 45

ACCESSORIES &
BUSINESS CHOICE | 46





COMMERCIAL

At GMC, we are Professional Grade. That means engineering, designing and building vehicles professionals demand. Our vehicles have constantly exceeded expectations. Our latest achievements can be found in the new 2016 Sierra 1500 and HD. You'll find that an 8-speed automatic transmission is now offered with the 6.3L V8 for enhanced efficiency. And, in both Sierra 1500 and HD, we continue to offer refined interiors, technologies, cargo box innovations and proven powertrains.

Starting fall 2015, Canyon will offer an all-new Duramax 2.8L Turbo Diesel designed to deliver capability, efficiency and durability.

These new vehicle offerings, like our entire lineup, prove that anything worth doing is worth doing well.



SIERRA 3500HD CREW CAB SLE
IN QUICKSILVER METALLIC
[LEFT]

CANYON CREW CAB SLE IN
BRONZE ALLOY METALLIC
[CENTER]

SIERRA 1500 CREW CAB SLE
IN QUICKSILVER METALLIC
[RIGHT]

All vehicles shown with available equipment



YOUR JOBS COME IN MANY SIZES. SO DO OUR TRUCKS.

MEET YOUR NEW EFFICIENCY EXPERT.

It's all about working smarter. And doing it all without sacrificing power for efficiency and capability for versatility. That's why we've engineered the Canyon to be one smart-sized package. It's efficient in its use of space, highly durable with a quiet, comfortable cabin and capable with robust payload and max trailering. Like the legendary Duramax V-8, Canyon's all-new available Duramax 2.8L I-4 Turbo Diesel engine delivers efficiency, durability and the strength to trailer up to 7700 lbs.¹ So now when it comes to moving Canyon from one project to another, all three engine options boast efficiency without sacrificing power, torque or a smooth ride.

A DURAMAX 2.8L I-4 TURBO DIESEL The Duramax 2.8L I-4 Turbo Diesel packs the power—with 181 horsepower at 3400 rpm and 369 lb-ft of torque at 2000 rpm—to tackle the toughest terrain. The Duramax 2.8L is a four-cylinder turbo diesel designed to deliver capability, durability and efficiency. It features a variable-geometry turbocharger for optimal power and efficiency across the rpm band and a balance shaft for greater smoothness. The engine is mated to a 6-speed automatic transmission.

B SPACIOUS CABIN Canyon sets a standard in truck cabins—especially ones this size. You'll find supportive, comfortable dual-firmness foam seats, generous Crew Cab rear-seat leg room, power four-way driver's seat and automatic climate controls.

C BOX DELETE This option allows business owners and fleet managers to customize the back of the 2016 Canyon. The Box Delete Package—RPD order code ZW9—is available on Canyon Work Truck 2WD Extended Cab models with the 305-hp 3.6L V-6 engine and 6-speed automatic transmission. Additional highlights: 2200-lb payload rating,² 6001-lb Gross Vehicle Weight Rating,² Z82 Trailering Package and eight body mount provisions.

¹Canyon's 7700-lb rating requires Crew Cab 2WD model, Duramax 2.8L I-4 engine and available Trailering Package. Before you buy a vehicle or use it for trailering, carefully review the trailering section of the Owner's Manual. The weight of passengers, cargo and options or accessories may reduce the amount you can tow. ²These maximum payload ratings are intended for comparison purposes only. Before you buy a vehicle or use it to haul people or cargo, carefully review the vehicle loading section of the Owner's Manual and check the carrying capacity of your specific vehicle on the label on the inside of the driver's doorjamb. ³When properly equipped, includes weight of vehicle, passengers, cargo and equipment. ⁴Vehicle user interface is a product of Apple[®] and Apple's[®] terms and privacy statements apply. Requires compatible smartphone. Data plan rates apply. ⁵Devices must be WPA2-compliant with active DnSnr service and data plan. Wi-Fi devices manufactured prior to 2006 may not be compatible. Please consult your device manufacturer for information regarding the WPA2 security protocol and Wi-Fi device compatibility. Vehicle must be started or in accessory mode to access Wi-Fi. Visit onstar.com for details and system limitations.



NEW FOR 2016 IS SUPPORT FOR APPLE CARPLAY.^{TM4} IT'S THE SMARTER WAY TO USE YOUR IPHONE[®] INSIDE YOUR CANYON (AVAILABLE)

NEW DURAMAX 2.8L I-4 TURBO DIESEL (AVAILABLE FALL 2015)

ONSTAR WITH 4G LTE AND BUILT-IN WI-FI[®] HOTSPOT⁵ (AVAILABLE)

FORWARD COLLISION ALERT AND LANE DEPARTURE WARNING KEEP YOU AWARE (AVAILABLE)

IMPRESSIVE PAYLOAD AND AMPLE CARGO BOX SIZE



CANYON CREW CAB SLE IN CYBER GRAY METALLIC
shown with available equipment.

PROFESSIONAL GRADE DELIVERS A NEW STANDARD IN ACHIEVEMENT.

The 2016 Sierra 1500 is engineered to help your entire crew work smarter. Inside, it's accommodating, technically advanced and highly supportive. On the road, choose from three engines with the latest technologies that produce work-minimizing power and profit-maximizing fuel efficiency.¹ The cargo box lends a well-deserved helping hand so your crew can haul more and do more. All together, this makes Sierra the truck your business demands.

COMFORTABLY SUPPORTIVE INTERIOR • Quiet full-size pickup • Lasting comfort seats • Generous storage options • Technology to keep you connected, informed and entertained • Rear doors and seats make getting into the Crew Cab and Double Cab easy

POWERFULLY EFFICIENT ECOTEC3 ENGINES • Our latest technologies: Direct Injection (DI), Active Fuel Management (AFM) and continuously Variable Valve Timing (VVT) • Deceleration Fuel Cutoff • Jet-Spray Piston Cooling • 5.3L V-8 and available 6.2L V-8 mated to a Hydra-Matic 8-speed automatic on SLT and Denali

INTELLIGENT CARGO MANAGEMENT • 6' 8" Crew Cab cargo box [Available] • Max payload of up to 2260 lbs² • New Remote Power Locking Tailgate [Available] • EZ-Lift and Lower Tailgate [Available] • Under-rail box lights [Available] • Movable upper box tie-down hooks • CornerStep rear bumper

DRIVER TECHNOLOGIES • 8" diagonal Color Touch Audio System with IntelliLink³ [Available] • OnStar 4G LTE with Wi-Fi hotspot⁴ [Available] • Forward Collision Alert and Lane Keep Assist [Available] • Safety Alert Driver Seat [Available] • Hands-free voice-activated Navigation System⁵ [Available] • Bluetooth[®] steering-wheel-mounted controls [Available] • Rear Vision Camera System [Available]

¹EPA-estimated mpg for 4.3L EcoTec3 engine: 18 city/24 hwy [2WD]; 5.3L EcoTec3 engine: 16 city/23 hwy [2WD]; 6.2L EcoTec3 engine: 15 city/21 hwy [2WD]. ²These maximum payload ratings are intended for comparison purposes only. Before you buy a vehicle or use it to haul people or cargo, carefully review the vehicle loading section of the Owner's Manual and check the carrying capacity of your specific vehicle on the label on the inside of the driver's door jamb. ³Full functionality requires compatible Bluetooth and smartphone. Some devices require USB connectivity. ⁴Devices must be WPA2-compliant with active OnStar service and data plan. Wi-Fi devices manufactured prior to 2006 may not be compatible. Please consult your device manufacturer for information regarding the WPA2 security protocol and Wi-Fi device compatibility. Vehicle must be started or in accessory mode to access Wi-Fi. Visit onstar.com for details and system limitations. ⁵Map coverage available in the United States, U.S. Virgin Islands, Puerto Rico and Canada. ⁶Go to my.gmc.com/learn to find out which phones are compatible with the vehicle. ⁷Requires 6.2L EcoTec3 V-8 and Max Trailering Package. Before you buy a vehicle or use it for trailering, carefully review the trailering section of the Owner's Manual. The weight of passengers, cargo and options or accessories may reduce the amount you can tow.

QUIET FULL-SIZE PICKUP CABIN

MAXIMUM TRAILER WEIGHT RATING OF UP TO 12,000 LBS⁷

MAXIMUM PAYLOAD OF UP TO 2260 LBS²

CORROSION-RESISTANT DURALIFE BRAKE ROTORS CAN HELP DOUBLE ROTOR LIFE

DRIVER ALERT PACKAGE [AVAILABLE]

NEW LANE KEEP ASSIST AND INTELLIBEAM [AVAILABLE]



SIERRA 1500 CREW CAB SLE IN CRIMSON RED TINTCOAT
shown with available equipment

NEW POWER LOCKING
TAILGATE WITH REMOTE
KEYLESS ENTRY (AVAILABLE)

SPRAY-IN BEDLINER WITH
GMC LOGO (AVAILABLE)

MOVABLE UPPER TIE-DOWN
HOOKS AND AVAILABLE
UNDER-RAIL BOX LIGHTS

MAXIMUM PAYLOAD OF
UP TO 2260 LBS*

MAXIMUM TRAILER WEIGHT
RATING OF UP TO 12,000 LBS*

SIERRA 1500 CREW CAB SLE IN QUICKSILVER METALLIC
shown with available equipment



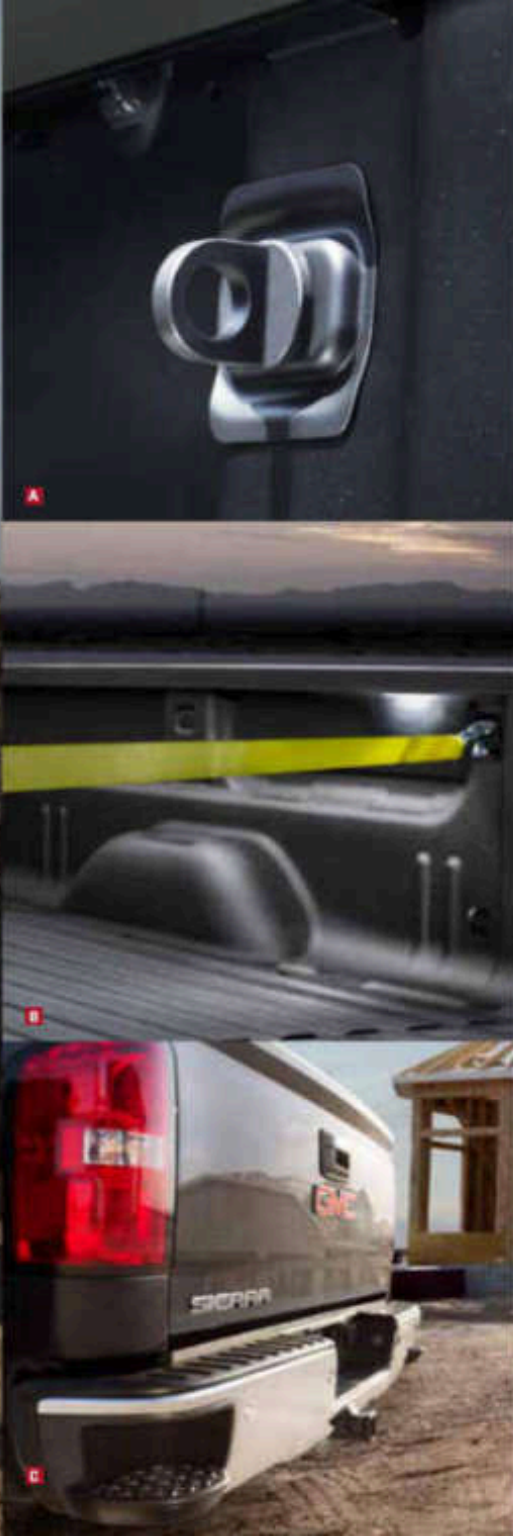

A TRUCK SMART ENOUGH TO MANAGE YOUR CARGO FOR YOU.

You already work hard. The 2016 Sierra 1500 helps you work smarter by solving cargo challenges. The available 6'6" cargo box on Crew Cab models gives you a choice of hauling options. And getting to the cargo box is easy with the EZ-Lift and Lower Tailgate, standard on most models.

A. MOVABLE TIE-DOWN HOOKS Four repositionable load-bearing upper tie-down hooks are standard and rated at 250 lbs each.¹

B. SPRAY-IN BEDLINER To provide a permanent, nonskid surface, the available black liner covers the entire bed below the side rails, including the tailgate, front box top rail and lower tie-down hooks.

C. CORNERSTEP REAR BUMPER Integrated into the corners, the steps make it easy to access the cargo box. The deep tread of the step is designed to accommodate large steel-toed boots.

¹These maximum payload ratings are intended for comparison purposes only. Before you buy a vehicle or use it to haul people or cargo, carefully review the vehicle loading section of the Owner's Manual and check the carrying capacity of your specific vehicle on the label on the inside of the driver's door jamb. ²Requires 5.2L EcoTec3 V-8 engine and Max Trailering Package. Before you buy a vehicle or use it for trailering, carefully review the trailering section of the Owner's Manual. The weight of passengers, cargo and options or accessories may reduce the amount you can tow. ³Cargo and load capacity limited by weight and distribution.

A QUIET PLACE TO WORK.

Since Sierra also doubles as your mobile office, our engineers achieved new standards for how quiet its interior could be. Hold meetings in solitude thanks to slick exterior aerodynamics, triple door seals, sound-absorbing materials and reduced engine noise. And since most work sites can be rough, new highly supportive seats help reduce fatigue, while durable materials minimize wear and tear over time.

A DURABLE MATERIALS You're surrounded by attractive, durable materials. On select models, the instrument panel features a soft-touch feel, real aluminum trim, contrasting stitching and an overall finished appearance. Purposeful design means door trim panels that are reinforced to stand up to everyday wear and tear.

B GENEROUS STORAGE We designed Sierra to help maximize space with a cavernous center console storage bin. You'll also appreciate the convenience of easy "grab and go" storage pockets integrated into the doors.

C STEERING-WHEEL-MOUNTED CONTROLS Keeping your eyes on the road, you can activate available Bluetooth® phone controls with your fingertips. The system links your compatible Bluetooth device to Sierra's audio system.

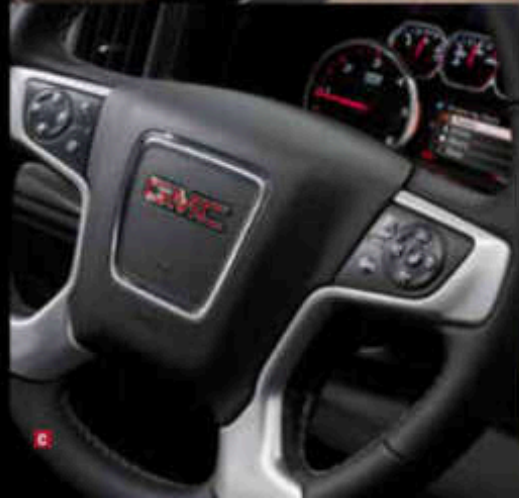



SIERRA 1500 CREW CAB SLE INTERIOR IN JET BLACK
shown with available equipment.

**SUPPORTIVE SEATS RETAIN THEIR
SHAPE AND REDUCE FATIGUE**

**SOFT-TOUCH INSTRUMENT
PANEL, REAL ALUMINUM TRIM
AND CONTRASTING STITCHING
(SLE AND SLT MODELS)**

**STORAGE BIN ACCOMMODATES
LAPTOPS (AVAILABLE)**

**STEERING-WHEEL-MOUNTED
CONTROLS (AVAILABLE)**

IT'S AMAZING WHAT YOU CAN ACCOMPLISH WITH THE RIGHT EQUIPMENT.

You shouldn't have to search around for gauges and controls. That's why Sierra's instrument panel puts information where it's most visible and accessible so you can concentrate on the road. All knobs and buttons are large to accommodate work gloves, while gauges are easy to read and LED back-lit for nighttime driving.

A INTELLILINK[®] The available GMC 8" diagonal Color Touch Sound System with IntelliLink features a full-color screen as well as hands-free, voice-activated control of your communication and entertainment selections. Stream Pandora[®] Internet radio² through your smartphone or sync your MP3 music library.

B WIRELESS CHARGING MAT³ With available wireless charging conveniently located on the center console, you can power up your compatible phone or device anytime the vehicle is running. No cord necessary.

C CENTER PANEL SWITCHBANK Controls and power sources are centrally located within easy reach of the driver's seat. Four available auxiliary switches allow you to add controls for a winch, additional lights, air compressors, power outlets and other equipment (more switches shown at right).

¹Full functionality requires compatible Bluetooth and smartphone. Some devices require USB connectivity. ²Data plan rates apply. ³The vehicle must be on or Retained Accessory Power must be active. Remove all objects from the charging pad. Place the mobile device face up on the charging symbol on the charging pad. Move the device slowly until the factory charging symbol displays on the touch-screen, indicating the device is charging. See your Infotainment System Owner's Manual. ⁴Vehicle user interface is a product of Apple[®] and Apple's terms and privacy statements apply. Requires compatible smartphone. Data plan rates apply. ⁵Vehicle user interface is a product of Google[®] and Google's terms and privacy statements apply. Requires compatible smartphone. Data plan rates apply. ⁶Not compatible with all devices. ⁷Devices must be WPA2-compliant with active OnStar service and data plan. Wi-Fi devices manufactured prior to 2000 may not be compatible. Please consult your device manufacturer for information regarding the WPA2 security protocol and Wi-Fi device compatibility. Vehicle must be started or in accessory mode to access Wi-Fi. Visit onstar.com for details and system limitations.



NEW APPLE CARPLAY[™] AND ANDROID AUTO[™] ARE THE SMART WAYS TO USE YOUR PHONE INSIDE SIERRA (AVAILABLE)

DRIVER ALERT PACKAGE NOW INCLUDES LANE KEEP ASSIST AND INTELLIBEAM (AVAILABLE)

COLOR TOUCH AUDIO SYSTEM WITH INTELLILINK[®] OFFERS VOICE-ACTIVATED CONTROL (AVAILABLE)

UP TO FIVE USB PORTS,⁴ FOUR AUXILIARY OUTLETS AND AN AVAILABLE 110-VOLT OUTLET

ONSTAR WITH 4G LTE AND BUILT-IN WI-FI HOTSPOT⁵ KEEPS YOU AND YOUR CREW CONNECTED (AVAILABLE)



SIERRA INTERIOR IN JET BLACK
shown with available equipment.

LET OUR POWER AND EFFICIENCY DRIVE YOUR BUSINESS.

Sierra's EcoTec3 engine family (4.3L V-6, 5.3L V-8 and 6.2L V-8) features GMC's latest technologies: Direct Injection (DI), Active Fuel Management (AFM) and continuously Variable Valve Timing (VVT) to deliver power and fuel efficiency.¹ In fact, the available 5.3L V-8 offers unexpected fuel economy.² New for 2016, the 5.3L V-8 along with the available 6.2L V-8 are paired with our Hydra-Matic 8-speed automatic transmission on SLT and Denali models.

DIRECT INJECTION For precise fuel distribution and fast, efficient combustion, all engines benefit from DI technology. The system moves the fuel closer to the ignition point in the engine—the combustion chamber.

ACTIVE FUEL MANAGEMENT By sensing load and demand, AFM improves fuel efficiency by activating or deactivating cylinders (two on the V-6 and four on the V-8).

CONTINUOUSLY VARIABLE VALVE TIMING For responsiveness in low-speed city driving and bold power for open-road passing or trailering, all Sierra engines feature continuously VVT.

¹EPA-estimated mpg for 4.3L EcoTec3 engine: 18 city/24 hwy [2WG]; 5.3L EcoTec3 engine: 16 city/23 hwy [2WG]; 6.2L EcoTec3 engine: 16 city/21 hwy [2WG]. ²EPA-estimated mpg for 5.3L EcoTec3 engine: 16 city/23 hwy [2WG]. *These maximum payload ratings are intended for comparison purposes only. Before you buy a vehicle or use it to haul people or cargo, carefully review the vehicle loading section of the Owner's Manual and check the carrying capacity of your specific vehicle on the label on the inside of the driver's door jamb. ³Requires 6.2L EcoTec3 engine and Max Trailering Package. Before you buy a vehicle or use it for trailering, carefully review the trailering section of the Owner's Manual. The weight of passengers, cargo and options or accessories may reduce the amount you can tow.

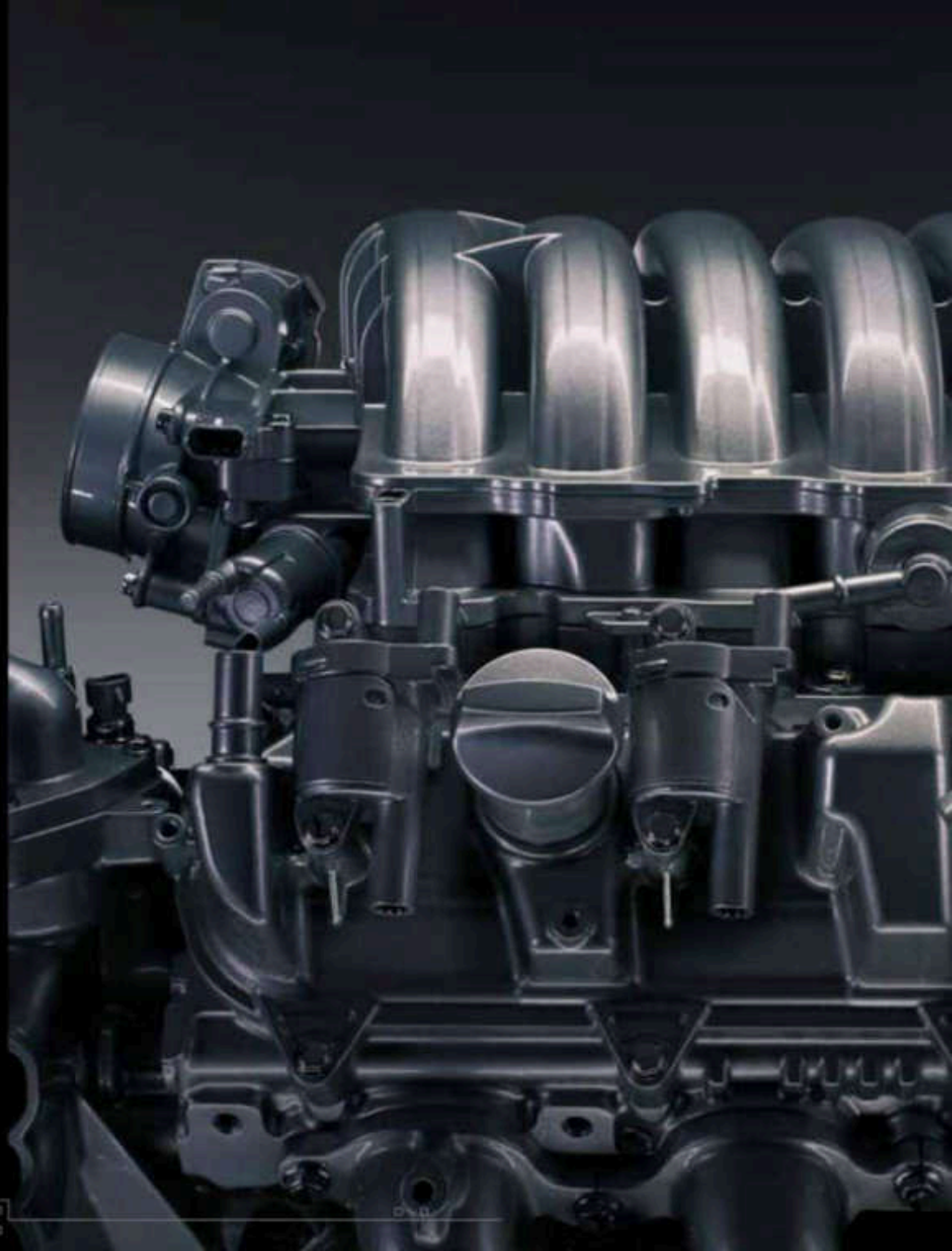

THE CORNERSTONE OF ANY STRUCTURE IS ITS FOUNDATION.

The 2016 Sierra is solid, thanks to meticulous attention to detail throughout its structure. That Professional Grade strength produces a maximum payload of more than one ton,³ as well as a maximum trailer weight rating of up to 12,000 lbs,⁴ based on SAE J2807 performance requirements. Providing the ultimate support is a hydroformed, boxed, high-strength steel frame. Connecting the body to the frame are shear and hydraulic body mounts. They work together to help manage side-to-side and up-and-down vibrations.

A ELECTRIC RACK-AND-PINION STEERING It improves fuel efficiency versus engine-powered systems. The variable assist provides less assist at highway speeds for a solid on-center feel, and more assist for less steering effort when maneuvering in tight spaces.

B COIL-OVER-SHOCK FRONT SUSPENSION This fully independent system is precisely tuned for improved handling. The front shock module increases road isolation in response to smaller vibration inputs. A thick spring isolator and a high spring rate produce a more controlled ride.

C CORROSION-RESISTANT BRAKES Duralife brake rotors can help double rotor life. This GM-exclusive corrosion protection is designed to prolong rotor life and protect against rust to help prevent brake shudder.

STABILITRAK This electronic stability control system helps improve stability by detecting and reducing traction loss. For rollover mitigation, StabiliTrak anticipates a vehicle "tip up" situation, rapidly braking to help reduce lateral forces and the likelihood of a rollover.

HILL START ASSIST Sensors detect when Sierra is on a 5 percent grade or more. It helps hold the brakes momentarily or until the accelerator is pressed, preventing rollback. It's most effective when trailering, allowing you to switch from the brake to the accelerator without rolling.

LARGE REAR AXLE With the 5.3L engine, the rear axle has a large [9.5"] ring gear. Choose the Max Trailering Package or the 6.2L engine and it increases to 9.76." These axles are engineered to handle the robust power and provide durability.



A

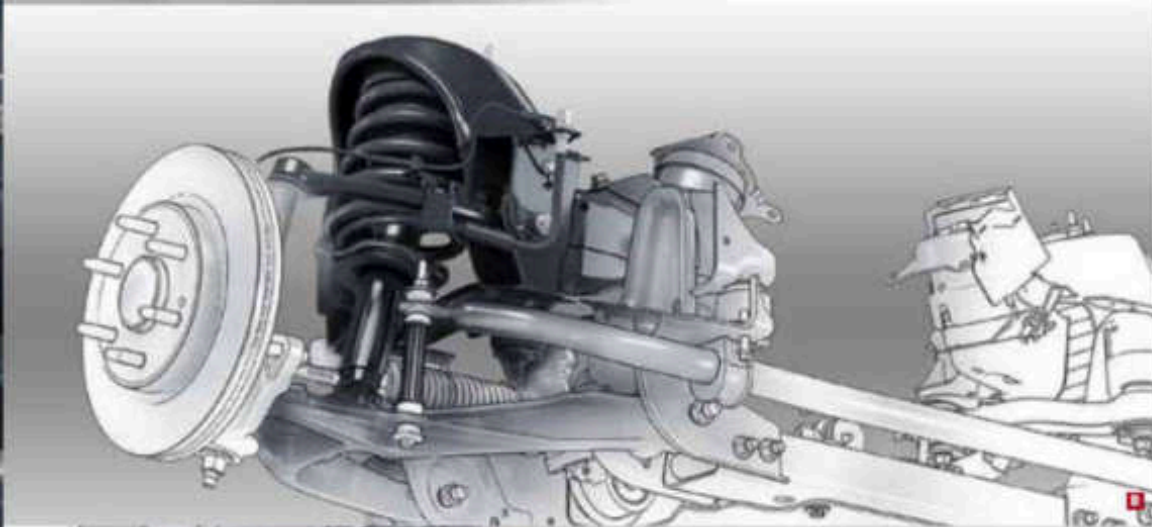

B

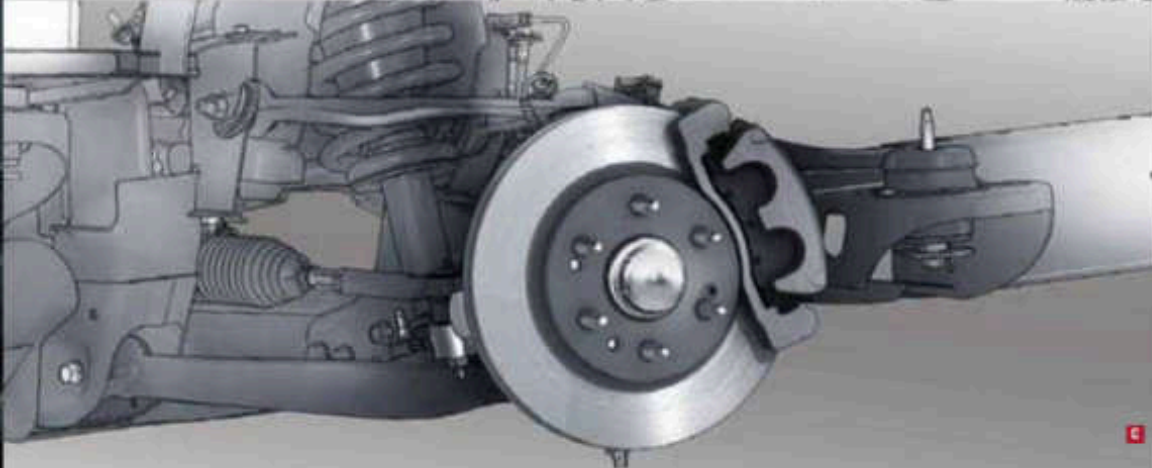

C

LIKE YOU, OUR ENGINEERS ALWAYS BUILD ON THEIR STRENGTHS.

You never rest on past achievements. At GMC, neither do we. The 2016 Sierra 2500HD and 3500HD take proven powertrains and add quiet, comfortable interiors, heavy-duty capability and cargo box innovations to produce a premium-duty breed of Professional Grade trucks. The available Duramax 6.6L V-8 Turbo Diesel engine delivers 397 horsepower and 765 lb-ft of torque.



A STANDARD HAS QUIETLY BEEN ACHIEVED The 2016 Sierra HD cabin combines triple door seals, inlaid doors and other refinements throughout to create a quiet environment. Premium materials, supportive seats and generous storage also help set the standard.

*Before you buy a vehicle or use it for trailering, carefully review the trailering section of the Owner's Manual. The weight of passengers, cargo and options or accessories may reduce the amount you can tow. †These maximum payload ratings are intended for comparison purposes only. Before you buy a vehicle or use it to haul people or cargo, carefully review the vehicle loading section of the Owner's Manual and check the carrying capacity of your specific vehicle on the label on the inside of the driver's door jamb. ‡Devices must be WPA2-compliant with active DoStar service and data plan. Wi-Fi devices manufactured prior to 2006 may not be compatible. Please consult your device manufacturer for information regarding the WPA2 security protocol and Wi-Fi device compatibility. Vehicle must be started or in accessory mode to access Wi-Fi. Visit gmtrac.com for details and system limitations. ††Vehicle user interface is a product of Apple® and Apple's® terms and privacy statements apply. Requires compatible smartphone. Data plan rates apply. †††Vehicle user interface is a product of Google and Google's terms and privacy statements apply. Requires compatible smartphone. Data plan rates apply.

MORE THAN 1 MILLION DURAMAX DIESELS WITH ALLISON® TRANSMISSIONS ON THE ROAD WITH MORE THAN 100 BILLION MILES OF EXPERIENCE

INNOVATIVE CARGO BOX OFFERS EZ-LIFT AND LOWER TAILGATE WITH A NEW REMOTE POWER LOCKING FEATURE, AVAILABLE LED UNDER-RAIL LIGHTS, MOVABLE UPPER TIE-DOWN HOOKS AND CORNERSTEP REAR BUMPER

A 1-TON CONVENTIONAL TRAILERING CAPABILITY OF UP TO 20,000 LBS¹ (AVAILABLE)

A 1-TON MAX FIFTH-WHEEL OR GOOSENECK TRAILERING CAPABILITY OF UP TO 23,200 LBS¹

A 1-TON MAX PAYLOAD CAPACITY OF UP TO 7153 LBS²

ONSTAR WITH 4G LTE AND BUILT-IN WI-FI HOTSPOT³ (AVAILABLE)

NEW APPLE CARPLAY™⁴ AND ANDROID AUTO⁵ ARE THE SMART WAYS TO USE YOUR PHONE INSIDE SIERRA (AVAILABLE)





SIERRA 3500HD CREW CAB SLT WITH DUAL REAR WHEELS IN ONYX BLACK
shown with available equipment.



CHASSIS CAB OFFERS A DIESEL WITH 397 HP AND 785 LB-FT OF TORQUE

CHASSIS CAB PRODUCES A PAYLOAD OF UP TO 7287 LBS¹

CHASSIS CAB FEATURES TWO FUEL TANKS TOTALING A 63.5-GALLON FUEL CAPACITY (APPRX.)

HIGH IDLE CONTROL (AVAILABLE)

SIERRA 3500HD CHASSIS CAB WITH DUAL REAR WHEELS IN SUMMIT WHITE shown with available equipment.

SIERRA CHASSIS CAB AND BOX DELETE

THE POWER YOU EXPECT.
THE CONTROL YOU DESERVE.

The GMC Sierra Chassis Cab or Box Delete is built for the toughest jobs. With up to 765 lb-ft of torque and 397 horsepower, a Professional Grade payload capacity of up to 7287 lbs¹ and a Gross Vehicle Weight Rating [GVWR] of up to 13,200 lbs,² the Chassis Cab is designed with power and strength. The lineup offers a standard Vortec 6.0L V-8 gas engine or an available Duramax 6.6L V-8 Turbo Diesel. Choose from 60" or 84" cab-to-axle lengths as well as Regular and Crew Cab options.

NEW LIGHT-DUTY BOX DELETE. For 2016, we're excited to introduce an industry-first Box Delete option for our 1500 series Sierra Regular Cab. Like the Box Delete on HD models, it requires a long box model and deletes the pickup box, rear bumper and spare tire carrier (it can be retained if necessary). This Box Delete includes high-rate rear springs and front stabilizer bar from our Max Trailering Package for better performance when operating near the truck's maximum GVWR. If you have lower payload requirements, this new option will reduce upfront costs and provide fuel-economy advantages compared to Heavy Duty Box Delete alternatives.

A POWER TAKE OFF (PTO) Sierra 3500HD Chassis Cab models equipped with the available Allison automatic transmission include a PTO control in the switchbank to accommodate a compatible aftermarket PTO to drive equipment such as a hydraulic dump body, hydraulic pumps or generators.

B INTEGRATED TRAILER BRAKE CONTROLLER Provides immediate and measured brake-force signaling to electric-controlled trailer brake systems.



SIERRA CREW CAB CHASSIS CAB
With dump body upfit.³



SIERRA REGULAR CAB CHASSIS CAB
With flatbed upfit.³

¹These maximum payload ratings are intended for comparison purposes only. Before you buy a vehicle or use it to haul people or cargo, carefully review the vehicle loading section of the Owner's Manual and check the carrying capacity of your specific vehicle on the label on the inside of the driver's door jamb. ²When properly equipped, includes weight of vehicle, passengers, cargo and equipment. ³Equipment added by an independent supplier. See page 47 for information about alterations and warranties.



LIKE YOUR BUSINESS, IT'S BUILT ON A STRONG FOUNDATION.

Weight robs a truck of its power and efficiency. In Sierra HD, the strategic use of high-strength Professional Grade steels and other premium materials enabled our engineers to create a strong, quiet and capable HD. We've precisely tuned the frame to help squelch vibration for a smooth ride and confident handling. It's a fortress of strength, and on Crew Cab and Double Cab models, the body rests on hydraulic body mounts for added comfort.

A SNOW PLOW PREP PACKAGE The front suspension utilizes precision machine-forged-steel upper control arms, robust torsion bars and our largest steering gear, producing a Front Gross Axle Weight Rating (FGAWR) of up to 6000 lbs.¹ So 4WD HD models can easily accommodate a snow plow with the available Snow Plow Prep Package.

B NEW ACTIVE STEERING ASSIST This available feature offers improved handling, an enhanced ability to hold the road, greater stability at high speeds and reduced sensitivity to uneven roads. These benefits are most appreciated while trailering.

C INDEPENDENT FRONT SUSPENSION Large, strong parts make the Sierra HD more capable and durable than anything we've offered before. But that hasn't sacrificed ride quality. The suspension allows the front wheels to react independently on rough terrain, helping keep each wheel in a vertical position. That means you'll enjoy great road isolation, exceptional tire-to-ground contact and reduced tire wear.

D NEW GOOSENECK/FIFTH-WHEEL PREP PACKAGE² Available on all cab types, the package includes a box-mounted trailer harness, hitch platform and hitch tray for factory-installed durability.

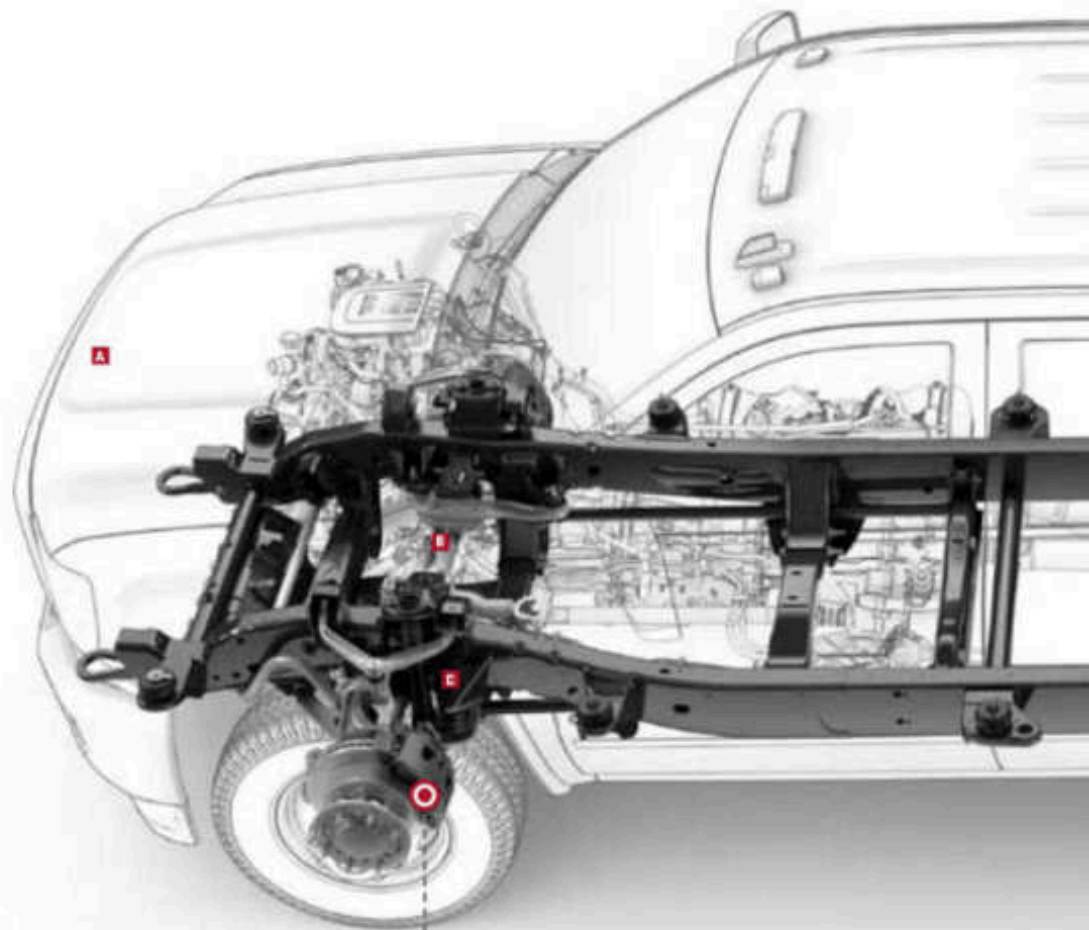

DURALIFE BRAKE ROTORS All Sierra HD brake rotors feature corrosion resistance to help provide up to double the rotor life.

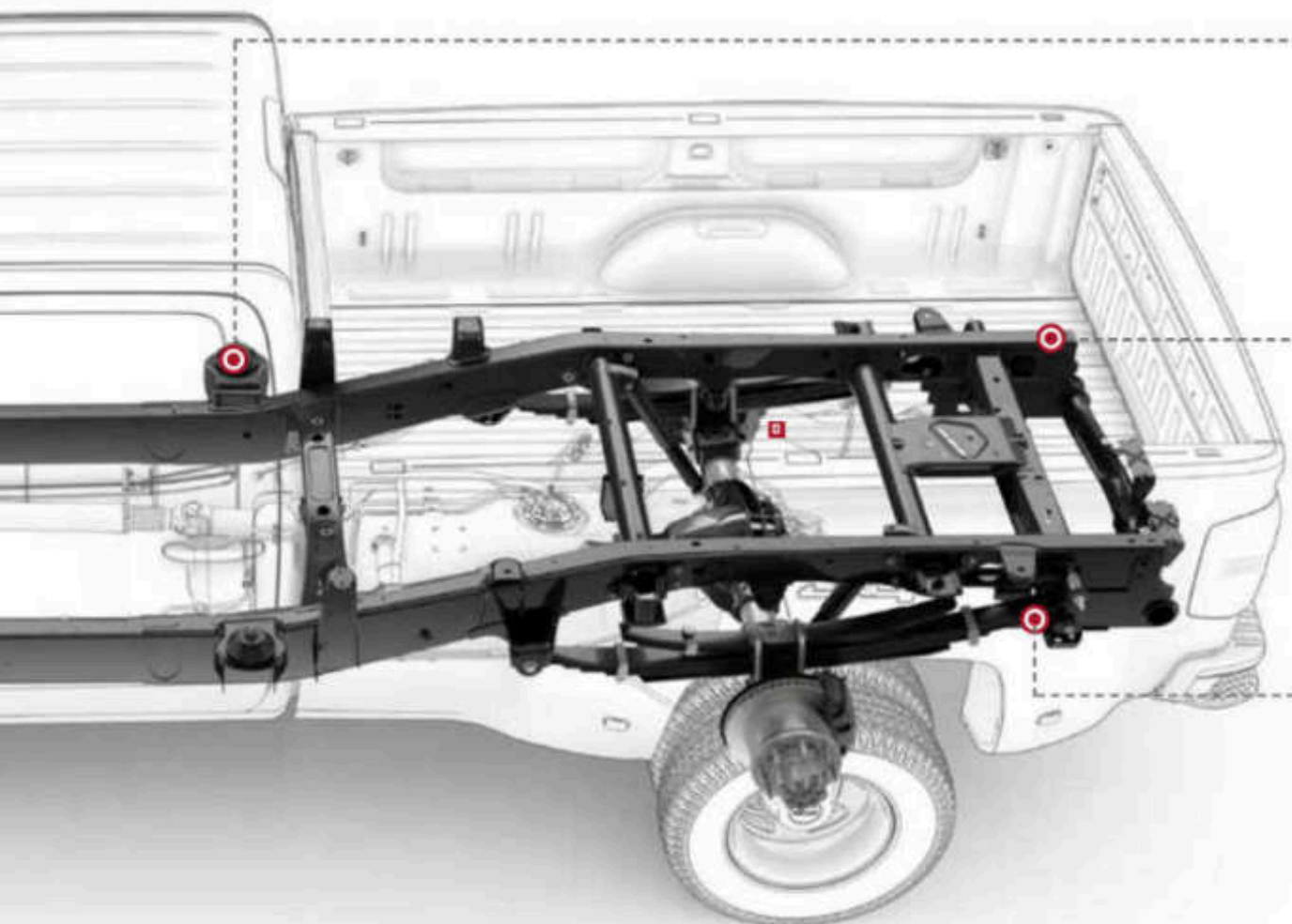

HYDRAULIC BODY MOUNTS On Crew Cab models, hydraulic body mounts improve ride quality by helping to isolate and absorb bumps.

FULLY BOXED STEEL FRAME With a fully boxed frame on pickup models, we increased the torsional rigidity and its resistance to twisting.

REAR SUSPENSION The asymmetrical leaf-spring design on pickup models (shorter in the front than in the rear) reduces "hop and shudder" and includes larger fasteners to handle the increased loads.



POWER. DEPENDABILITY. PROVEN. A MILLION TIMES OVER.

Sierra HD gets its heavy-duty power from proven sources, including the available Duramax 6.6L V-8 Turbo Diesel mated to the Allison 6-speed automatic transmission. You'll find more than 1 million Duramax diesels with Allison transmissions on the road today with more than 100 billion miles of real-world experience. The Compressed Natural Gas (CNG)/Gasoline Bi-Fuel System available on select single-rear-wheel and Chassis Cab models helps you reduce fuel costs and environmental impact.

POWER AND EFFICIENCY The available Duramax Diesel delivers 397 hp and 765 lb-ft of torque. The Duramax also offers up to 680 highway miles to a tank of fuel.¹

DIESEL EXHAUST BRAKE Our "smart" system varies the amount of engine braking needed based on the truck load and grade. It extends the life of your brakes by reducing brake heating and improves safety by reducing brake fade, even when towing heavy trailers. Included with the Duramax Diesel engine.

B20 BIODIESEL-FUEL COMPATIBLE Our Duramax 6.6L V-8 Turbo Diesel with direct injection can also run on B20 fuel (a blend of 20 percent biodiesel and 80 percent diesel).

ALLISON TRANSMISSION The available Allison 1000 6-speed automatic lets you activate Tow/Haul mode by pressing a button at the end of the shift lever. Also, by using the +/- button, you can select the range of gears for your driving conditions.

VORTEC 6.0L V-8 The standard Vortec 6.0L V-8 delivers up to 360 hp at 5400 rpm and 380 lb-ft of torque at 4200 rpm.

E85² To give you more choices at the pump, the 6.0L Vortec V-8 engine is capable of running on E85 ethanol, an advanced biofuel.

BI-FUEL 6.0L VORTEC V-8 Our 6.0L Vortec V-8 engine includes hardened exhaust valves and intake/exhaust valve seats, allowing it to run on either CNG or gasoline. The combined 17 Gasoline Gallon Equivalent (GGE) CNG tank [approx.] and 36-gallon gasoline tank [approx.] provide a range of up to 625 miles.³

5-YEAR/100,000-MILE
DIESEL POWERTRAIN
LIMITED WARRANTY⁴

DURAMAX 6.6L V-8 TURBO
DIESEL ENGINE DELIVERS
397 HP AND 765 LB-FT OF
TORQUE [AVAILABLE]

CNG FUEL SYSTEM REDUCES
COSTS AND ENVIRONMENTAL
IMPACT [AVAILABLE]

DURAMAX 6.6L V-8 TURBO
DIESEL WITH ALLISON 1000
TRANSMISSION OFFERS A
MAXIMUM HIGHWAY RANGE OF
UP TO 680 MILES¹ [AVAILABLE]



¹Based on GM testing and fuel tank capacity. Your range may be less. ²E85 FlexFuel capability is not available in AZ, CA, CT, DE, MA, MD, ME, NJ, NY, OR, PA, RI, VT and WA. E85 is a combination of 85% ethanol and 15% gasoline. Go to efdc.energy.gov/efdc/fuels to see if there is an E85 fuel station near you. ³Whichever comes first. See dealer for details. Fully transferable, no deductible.

S = Standard A = Available -- = Not Available

ENGINE AVAILABILITY	SAE NET HP @ RPM	TORQUE (LB-FT) @ RPM	EXTENDED CAB		CREW CAB	
			2WD	4WD	2WD	4WD
2.5L I-4 (260 cu. in.)	230 @ 6300	191 @ 4400	S	S	S*	--
Duramax 2.8L I-4 Turbo Diesel	181 @ 3400	368 @ 2000	--	--	A*	A*
3.6L V-6 (317 cu. in.)	305 @ 6000	265 @ 4000	A	A	A*	S*
TRANSMISSION						
5-Speed Manual			S	--	--	--
5-Speed Automatic			A	S	S	S
AXLE RATIO						
3.42 (V-6/Duramax Diesel)			A	A	A	A
4.10 (I-4)			S	S	S	--
CAPACITY						
GVMR (lbs) ¹			6400-6700	6600-6900	6600-6900	6000-6200
Payload (lbs) ²			1370-1620	1340-1590	1380-1620	1380-1590
MAX TRAILERING						
Cab Type	Extended Cab		Crew Cab			
Box Length	Long (8' 2")		Short (5' 2")		Long (8' 2")	
Engine	2.5L I-4	3.6L V-6	2.5L I-4	3.6L V-6	2.8L I-4 Turbo Diesel	3.6L V-6
Axle Ratio (2WD/4WD)	4.10/4.10	3.42/3.42	4.30/--	3.42/3.42	3.42/3.42	3.42/3.42
Maximum Trailer Weight (2WD/4WD) ³	2500/3500	7000/7000	3500/--	7000/7000	7700/7900	7000/7000
DIMENSIONS						
Cab Type	Extended Cab		Crew Cab			
Box Length	Long (8' 2")		Short (5' 2")		Long (8' 2")	
Wheelbase (in.)	128.3		128.3		140.5	
Overall Length (in.)	212.4		212.4		224.6	
Overall Width Without Mirrors (in.)	74.3		74.3		74.3	
Overall Height at Roof (in.) (excludes antenna)	70.4		70.7		70.8	
Cargo Box Length at Floor (in.)	74.0		61.7		74.0	
Cargo Box Width (in.)	57.8		57.8		57.8	
Fuel Tank Capacity in Gallons (approx.)	21		21		21	
Standard Wheels (in.)	16		16		16	

¹Not available on Crew Cab Long Box models. ²Available on SLE and SLT models. ³Standard on Crew Cab Long Box models. ⁴Standard on Crew Cab SLE, SLT and Long Box models. ⁵When properly equipped, includes weight of vehicle, passengers, cargo and equipment. ⁶These maximum payload ratings are intended for comparison purposes only. Before you buy a vehicle or use it to haul people or cargo, carefully review the vehicle loading section of the Owner's Manual and check the carrying capacity of your specific vehicle on the label on the inside of the driver's door jamb. ⁷Before you buy a vehicle or use it for trailering, carefully review the trailering section of the Owner's Manual. The weight of passengers, cargo and options or accessories may reduce the amount you can tow.

CANYON CABS & BEDS



Extended Cab | Long Box | 2WD | 4WD



Crew Cab | Short Box | 2WD | 4WD



Crew Cab | Long Box | 2WD | 4WD

S = Standard A = Available -- = Not Available

	SAE NET HP @ RPM	TORQUE [LB-FT] @ RPM	REGULAR CAB		DOUBLE CAB		CREW CAB	
			2WD	4WD	2WD	4WD	2WD	4WD
ENGINE AVAILABILITY								
4.3L EcoTec3 V-6 (262 cu. in.)	285 @ 5300	305 @ 3300	S	S	S	S	S	S
5.3L EcoTec3 V-8 (325 cu. in.)	355 @ 5800	383 @ 4100	A	A	A	A	A	A
6.2L EcoTec3 V-8 (376 cu. in.)	420 @ 5800	460 @ 4100	-	-	A	A	A	A
TRANSMISSION								
6-Speed Automatic			S	S	S	S	S	S
8-Speed Automatic			-	-	A	A	A	A
AXLE RATIO								
1.00			A	A	A	A	A	A
1.25			A	-	A	A	A	A
1.42			A	A	A	A	A	A
1.73			-	-	A	A	A	A
CAPACITY								
DVWR (lbs) ¹			6500-6800	6700-7000	6900-7400	7100-7600	6900-7400	7100-7600
Front GAWR (lbs)			3300	3950	3850	3950	3850	3950
Rear GAWR (lbs)			3800-3950	3950-3950	3950-4300	3950-4300	3950-4300	3950-4300
Payload (lbs) ²			1500-1950	1640-1900	1820-2260	1810-2220	1670-2160	1650-2130
MAX TRAILERING								
Cab Type			Regular Cab		Double Cab	Crew Cab		
Box Length			Standard	Long	Standard	Short	Standard	
Engine			5.3L EcoTec3	5.3L EcoTec3	6.2L EcoTec3	6.2L EcoTec3	6.2L EcoTec3	
Axle Ratio (2WD/4WD)			1.42/1.42	1.42/1.42	1.42/1.42	1.42/1.42	1.42/1.42	
Maximum Trailer Weight (2WD/4WD) ³			6800/6800	9600/9500	12,000/11,850	12,000/11,700	11,500/11,700	
DIMENSIONS								
Cab Type			Regular Cab		Double Cab	Crew Cab		
Box Length			Standard	Long	Standard	Short	Standard	
Wheelbase (in.)			716.0	133.0	143.5	143.5	153.0	
Overall Length (in.)			204.8	223.7	229.3	229.3	238.8	
Overall Height (in.)			73.5-74.1	73.5-74.1	73.5	72.7-74.1	72.7-74.1	
Cargo Box Length (in.)			78.9	97.8	78.9	59.3	78.9	
Overall Width (in.)			80.0	80.0	80.0	80.0	80.0	
Cab to Axle (in.)			41.4	55.4	41.5	32.0	41.5	
Fuel Tank Capacity in Gallons (approx.)			26	34	26	26	26	
Standard Wheels (in.)			17	17	17	17	17	

¹When properly equipped. Includes weight of vehicle, passengers, cargo and equipment. ²These maximum payload ratings are intended for comparison purposes only. Before you buy a vehicle or use it to haul people or cargo, carefully review the vehicle loading section of the Owner's Manual and check the carrying capacity of your specific vehicle on the label on the inside of the driver's door jamb. ³Before you buy a vehicle or use it for trailering, carefully review the trailering section of the Owner's Manual. The weight of passengers, cargo and options or accessories may reduce the amount you can tow. *2WD Sierra Crew Cab Standard Box requires Fleet order type.

SIERRA 1500 CABS & BEDS



Regular Cab | Standard Box | 2WD | 4WD



Regular Cab | Long Box | 2WD | 4WD



Double Cab | Standard Box | 2WD | 4WD



Crew Cab | Short Box | 2WD | 4WD



Crew Cab | Standard Box | 2WD | 4WD

S = Standard A = Available -- = Not Available

ENGINE AVAILABILITY	SAE NET HP @ RPM	TORQUE (LB-FT) @ RPM	REGULAR CAB		DOUBLE CAB		CREW CAB		
			2WD	4WD	2WD	4WD	2WD	4WD	
Vortec 6.0L V-8 HD (366 cu. in.)	360 @ 5400	380 @ 4200	S	S	S	S	S	S	
Vortec 6.0L CNG V-8 (366 cu. in.)	360 @ 5400 Gas 301 @ 5300 CNG	380 @ 4200 Gas 333 @ 4200 CNG	A	A	A	A	A	A	
Duramax 6.6L V-8 Turbo Diesel (402 cu. in.)	397 @ 3000	765 @ 1600	A	A	A	A	A	A	
TRANSMISSION									
6-Speed Heavy Duty Automatic with 6.0L			S	S	S	S	S	S	
8-Speed Allison Heavy-Duty Automatic with 6.6L Turbo Diesel			A	A	A	A	A	A	
AXLE RATIO									
3.73:1 (Standard with Duramax 6.6L V-8 Turbo Diesel)			A	A	A	A	A	A	
4.10:1 (6.0L V-8 engines only)			S	S	S	S	S	S	
CAPACITY									
GVWR (lbs) ¹			9300-10,000	9500-9800	9500-10,000	9500-10,000	9500-10,000	9500-10,000	
Front GAWR (lbs) Gas			4450	4400*	4400	4400-4600	4400-4800	4600*	
Front GAWR (lbs) Diesel			4800	5200*	5200	5200-5600*	5200	5200-5600*	
Rear GAWR (lbs)			5200-5700	5200	5200	5200	5200	5200	
Payload (lbs) ²			2575-4043	2754-3405	2728-3383	2331-3094	2466-3232	2287-3182	
MAX TRAILERING									
Cab Type	Regular Cab		Double Cab			Crew Cab			
Box Length	Long		Standard		Long		Standard		Long
Engine	Vortec 6.0L V-8 ³	Duramax 6.6L V-8 Turbo Diesel	Vortec 6.0L V-8 ³	Duramax 6.6L V-8 Turbo Diesel	Vortec 6.0L V-8 ³	Duramax 6.6L V-8 Turbo Diesel	Vortec 6.0L V-8 ³	Duramax 6.6L V-8 Turbo Diesel	Vortec 6.0L V-8 ³
Axle Ratio (2WD/4WD)	4.10/4.10	3.73/3.73	4.10/4.10	3.73/3.73	4.10/4.10	3.73/3.73	4.10/4.10	3.73/3.73	4.10/4.10
Maximum Conventional Trailer Weight (2WD/4WD) ⁴	14,500/14,500	14,500/14,500	13,000/13,000	13,000/13,000	14,400/14,100	14,500/14,500	13,000/13,000	13,000/13,000	14,300/13,900
Maximum Fifth-Wheel/Gooseneck Trailer Weight (2WD/4WD) ⁴	14,800/14,500	18,000/16,400	14,500/14,200	16,900/14,900	14,400/14,100	16,300/14,200	14,300/14,000	15,800/13,900	14,200/13,900
DIMENSIONS									
Cab Type	Regular Cab		Double Cab			Crew Cab			
Box Length	Long		Standard		Long		Standard		Long
Wheelbase (in.)	133.8		144.2		158.3		153.7		167.3
Overall Length (in.)	224.4		230.0		246.5		239.6		258.4
Overall Height (in.)	71.8		70.1		71.9-71.9		70.2-70.3		70.0
Cargo Box Length (in.) ⁵	87.8		79.3		81.0		76.9		81.8
Overall Width (in.)	80.5		80.5		80.5		80.5		80.5
Cab to Axle (in.)	55.2		41.3		55.2		41.3		55.2
Gasoline Fuel Tank Capacity in Gallons (approx.) ⁶	36		36		36		36		36
Standard Wheels (in.)	17		17		17		17		17

¹When properly equipped, includes weight of vehicle, passengers, cargo and equipment. ²5200 lbs with available Snow Plow Prep Package. ³5200 lbs with Standard Box and available Snow Plow Prep Package and 5600 lbs with Long Box and available Snow Plow Prep Package. ⁴10000 lbs with available Snow Plow Prep Package. ⁵These maximum payload ratings are intended for comparison purposes only. Before you buy a vehicle or use it to haul people or cargo, carefully review the vehicle loading section of the Owner's Manual and check the carrying capacity of your specific vehicle on the label on the inside of the driver's door jamb. ⁶Before you buy a vehicle or use it for trailering, carefully review the trailering section of the Owner's Manual. The weight of passengers, cargo and options or accessories may reduce the amount you can tow. ⁷See your GMC dealer for more details and availability on Vortec 6.0L CNG V-8-equipped models. ⁸See your GMC dealer for length of Cargo Box of CNG-equipped models. ⁹See your GMC dealer for additional information on CNG-model fuel tank capacities.

SIERRA 2500HD
CABS & BEDS

Regular Cab | Long Box | 2WD | 4WD

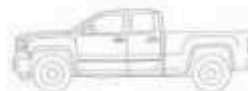

Double Cab | Standard Box | 2WD | 4WD

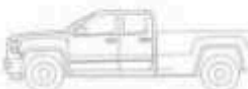

Double Cab | Long Box | 2WD | 4WD

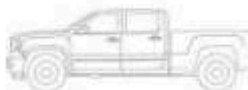

Crew Cab | Standard Box | 2WD | 4WD



Crew Cab | Long Box | 2WD | 4WD

S = Standard A = Available -- = Not Available

ENGINE AVAILABILITY	SAE NET HP @ RPM	TORQUE (LB-FT) @ RPM	REGULAR CAB				DOUBLE CAB				CREW CAB			
			3500HD SRW 2WD ¹	3500HD SRW 4WD	3500HD DRW 2WD	3500HD DRW 4WD	3500HD SRW 2WD ¹	3500HD SRW 4WD ¹	3500HD DRW 2WD	3500HD DRW 4WD	3500HD SRW 2WD ¹	3500HD SRW 4WD ¹	3500HD DRW 2WD	3500HD DRW 4WD
Vortec 6.0L V-8 HD (366 cu. in.)	360 @ 5400	300 @ 4200	S	S	S	S	S	S	S	S	S	S	S	S
Vortec 6.0L CNG V-8 (366 cu. in.)	360 @ 5400 Gas 301 @ 5000 CNG	300 @ 4200 Gas 331 @ 4200 CNG	A	A	--	--	A	A	--	--	A	A	--	--
Duramax 6.6L V-8 Turbo Diesel (402 cu. in.)	397 @ 3000	765 @ 1600	A ²	A	A ²	A	A	A	A	A	A	A	A	A
TRANSMISSION														
5-Speed Heavy-Duty Automatic with 6.0L			S	S	S	S	S	S	S	S	S	S	S	S
6-Speed Allison Heavy-Duty Automatic with 6.6L Turbo Diesel			A	A	A	A	A	A	A	A	A	A	A	A
AXLE RATIO														
3.73:1 (Standard on Duramax 6.6L V-8 Turbo Diesel)			A	A	A	A	A	A	A	A	A	A	A	A
4.30:1 (6.0L V-8 engines only)			S	S	S	S	S	S	S	S	S	S	S	S
CAPACITY														
GVWR (lbs) ³			10,400- 11,300	10,700- 11,400	13,025- 13,500	13,025- 13,400	10,700- 11,200	11,000- 11,600	13,025	13,025	10,500- 11,400	10,800- 11,600	13,025	13,025
Front GAWR (lbs) Gas			4400	4400 ⁴	4400	4400 ⁴	4400	4800 ⁴	4800	4800 ⁴	4800	4800 ⁴	4800	4800 ⁴
Front GAWR (lbs) Diesel			4800 ⁴	5200 ⁴	4800 ⁴	5200 ⁴	5200	5600 ⁴	5200	5600 ⁴	5200	5600 ⁴	5400	5600 ⁴
Rear GAWR (lbs)			7050	7050	9375-9825	9375-9825	7050	7050	9375	9375	7050	7050	9375	9375
Payload (lbs) ⁵			3735-4330	2696-4351	7853	6587-6723	3582-4272	3602-4292	5475-6234	5195-5855	3465-4147	3415-4195	5352-6111	5002-5743
MAX TRAILERING														
Cab Type	Regular Cab SRW		Regular Cab DRW		Double Cab SRW		Double Cab DRW		Crew Cab SRW		Crew Cab SRW		Crew Cab DRW	
Box Length	Long		Long		Long		Long		Standard		Long		Long	
Engine	Vortec 6.0L V-8 ⁶	Duramax 6.6L V-8 Turbo Diesel	Vortec 6.0L V-8	Duramax 6.6L V-8 Turbo Diesel	Vortec 6.0L V-8 ⁶	Duramax 6.6L V-8 Turbo Diesel	Vortec 6.0L V-8	Duramax 6.6L V-8 Turbo Diesel	Vortec 6.0L V-8 ⁶	Duramax 6.6L V-8 Turbo Diesel	Vortec 6.0L V-8 ⁶	Duramax 6.6L V-8 Turbo Diesel	Vortec 6.0L V-8	Duramax 6.6L V-8 Turbo Diesel
Axle Ratio (2WD/4WD)	4.10/4.10	NA/3.73	4.10/4.10	NA/3.73	4.10/4.10	3.73/3.73	4.10/4.10	3.73/3.73	4.10/4.10	3.73/3.73	4.10/4.10	3.73/3.73	4.10/4.10	3.73/3.73
Maximum Conventional Trailer Weight (2WD/4WD) ⁷	14,500/ 14,500	NA/ 14,500	14,300/ 14,000	NA/ 20,000	14,200/ 13,900	14,500/ 14,500	13,800/ 13,600	20,000/ 20,000	13,000/ 13,000	13,800/ 13,000	14,500/ 13,700	14,600/ 16,000	13,700/ 13,400	20,000/ 20,000
Maximum Fifth-Wheel/Scissor- neck Trailer Weight (2WD/4WD) ⁷	14,500/ 14,300	NA/ 11,600	14,500/ 13,900	NA/ 23,200	14,200/ 13,900	17,400/ 17,100	13,800/ 13,600	23,100/ 22,800	14,200/ 13,900	17,600/ 17,200	14,300/ 13,700	17,300/ 16,900	13,700/ 13,300	22,900/ 22,600
DIMENSIONS														
Cab Type	Regular Cab				Double Cab				Crew Cab					
Box Length	Long				Long				Standard					
Wheelbase (in.)	133.5				166.1				163.7					
Overall Length (in.)	224.4				248.3				235.5					
Overall Height (in.)	77.4-77.8				77.8-78.0				78.1-78.3					
Cargo Box Length (in.)	97.8				97.8				78.9					
Overall Width (in.) (SRW/DRW)	80.5/96.0				80.5/96.0				80.5/96.0					
Cab to Axle (in.)	55.2				55.2				41.3					
Fuel Tank Capacity in Gallons (approx.)	36				36				36					
Standard Wheels (in.) SRW	18				18				18					
Standard Wheels (in.) DRW	17				17				17					

¹Optional 10,000 lbs GVWR available on Single Rear Wheel 3500HD models with gas engine, except 4WD Crew Cab with Long Box. ²Steel available only with box delete. ³When properly equipped, includes weight of vehicle, passengers, cargo and equipment. ⁴5800 lbs with available Snow Plow Prep Package. ⁵6200 lbs with available Snow Plow Prep Package. ⁶These maximum payload ratings are intended for comparison purposes only. Before you buy a vehicle or use it to haul people or cargo, carefully review the vehicle loading section of the Owner's Manual and check the carrying capacity of your specific vehicle on the label on the inside of the driver's door jamb. ⁷Before you buy a vehicle or use it for trailering, carefully review the trailering section of the Owner's Manual. The weight of passengers, cargo and options or accessories may reduce the amount you can tow. ⁸See your GMC dealer for more details and availability on Vortec 6.0L CNG V-8-equipped models.

SIERRA 3500HD
SERIES SINGLE REAR WHEEL

Regular Cab | Long Box | 2WD | 4WD

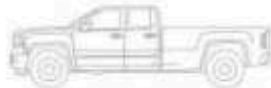

Double Cab | Long Box | 2WD | 4WD



Crew Cab | Standard Box | 2WD | 4WD

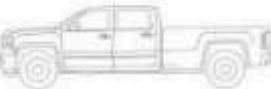

Crew Cab | Long Box | 2WD | 4WD

S = Standard A = Available -- = Not Available

ENGINE AVAILABILITY	SAE NET HP @ RPM	TORQUE [LB-FT] @ RPM	3500HD DRW REGULAR CAB		3500HD DRW CREW CAB	
			2WD	4WD	2WD	4WD
Vortec 5.0L V-8 Heavy Duty (361 cu. in.)	360 @ 5400	380 @ 4200	S	S	S	S
Vortec 5.0L CNG V-8 (361 cu. in.)	360 @ 5400 Gas 301 @ 5000 CNG	380 @ 4200 Gas 333 @ 4700 CNG	A	A	-	-
Duramax 6.6L V-8 Turbo Diesel (402 cu. in.)	397 @ 3000	765 @ 1600	A	A	A	A
TRANSMISSION						
6-Speed Heavy-Duty Automatic with 6.0L			S	S	S	S
6-Speed Allison Heavy-Duty Automatic with 6.6L Turbo Diesel			A	A	A	A
AXLE RATIO						
3.73:1 (Standard with Duramax 6.6L V-8 Turbo Diesel)			A	A	A	A
4.10:1 (I.L.D.L. V-8 only)			A	A	A	A
CAPACITY						
GVMR (lbs) ¹			13,200	13,200	13,200	13,200
Front GAWR (lbs) Gas			4400-4800	4400-5200	4400	4800
Front GAWR (lbs) Diesel			4800-5600	5200-5600	5200	5600
Rear GAWR (lbs)			8750	8750	8750	8750
Payload (lbs) ²			6332-7267	6987-6950	5829-6580	5477-6227
MAX GROSS COMBINATION WEIGHT RATING (GCWR)						
Cab Type			Regular Cab		Crew Cab	
Engine			Vortec 5.0L V-8	Duramax 6.6L V-8 Turbo Diesel	Vortec 5.0L V-8	Duramax 6.6L V-8 Turbo Diesel
Axle Ratio (2WD/4WD)			4.10/4.10	3.73/3.73	4.10/4.10	3.73/3.73
GCWR (2WD/4WD) ³			21,000/21,000	31,000/31,000	21,000/21,000	31,000/31,000
DIMENSIONS						
Cab Type			Regular Cab		Crew Cab	
Wheelbase (in.)			137.5/162.0		171.5	
Overall Length (in.)			229.5/254.0		283.5	
Overall Height (in.)			71.6		77.6	
Overall Width (in.)			95.6		95.6	
Cab to Axle (in.)			88.1/83.6		88.1	
Fuel Tank Capacity in Gallons (approx.)			63.5		63.5	
Standard Wheels (in.)			17		17	

¹When properly equipped, includes weight of vehicle, passengers, cargo and equipment. ²These maximum payload ratings are intended for comparison purposes only. Before you buy a vehicle or use it to haul people or cargo, carefully review the vehicle loading section of the Owner's Manual and check the carrying capacity of your specific vehicle on the label on the inside of the driver's door jamb. ³When properly equipped, includes weight of the vehicle and trailer combination, including the weight of driver, passengers, fuel, optional equipment and cargo in the vehicle and trailer.

SIERRA 3500HD SERIES DUAL REAR WHEEL



Regular Cab | Long Box | 2WD | 4WD



Double Cab | Long Box | 2WD | 4WD



Crew Cab | Long Box | 2WD | 4WD

SIERRA 3500HD SERIES CHASSIS CAB

Regular Cab
80" and 94" Cab-to-Axis | 2WD | 4WDCrew Cab
80" Cab-to-Axis | 2WD | 4WD

ALL YOUR EMPLOYEES SHOULD BE THIS VERSATILE.

We designed Savana Cargo Van to help you no matter what the workday brings. Choose payload and interior space combinations to suit your needs. It offers a base payload of 3247 lbs¹ and 270.4 cu. ft. of maximum cargo space²—and it now includes six new cargo D-ring tie-downs. Savana Cargo Van Extended Wheelbase models offer even more capability, with up to 3899 lbs of payload¹ and 313.9 cu. ft. of maximum cargo space.² A variety of fuel systems is available: 4.8L or 6.0L V-8 gasoline, our proven Duramax 6.6L V-8 Turbo Diesel or the dedicated CNG alternative fuel systems.

A SAVANA PRO PACKAGE Side-access storage bins on the Savana Pro Package maximize underused areas in standard vans. It provides plenty of cargo space and a flat load floor, so it easily adapts to your needs.

B REAR VISION CAMERA SYSTEM This available system places a monitor in your rearview mirror (or navigation screen, if equipped) to display a view of the area behind the vehicle, making it easier to back up to a trailer or negotiate a tight space.

C ONSTAR WITH 4G LTE AND BUILT-IN WI-FI³ HOTSPOT New available OnStar with 4G LTE and a built-in Wi-Fi hotspot includes a 3-month or 3GB data trial (whichever comes first) for a fast internet connection for Web-enabled devices from up to 50 feet around Savana. It's reliable, easy to use and handles up to seven mobile devices.

¹These maximum payload ratings are intended for comparison purposes only. Before you buy a vehicle or use it to haul people or cargo, carefully review the vehicle loading section of the Owner's Manual and check the carrying capacity of your specific vehicle on the label on the inside of the driver's door jamb. ²Cargo and load capacity limited by weight and distribution. ³Devices must be WPA2-compliant with active OnStar service and data plan. Wi-Fi devices manufactured prior to 2006 may not be compatible. Please consult your device manufacturer for information regarding the WPA2 security protocol and Wi-Fi device compatibility. Vehicle must be started or in accessory mode to access Wi-Fi. Visit onstar.com for details and system limitations.



NEW ONSTAR WITH 4G LTE AND BUILT-IN WI-FI HOTSPOT³ (AVAILABLE)

**ASSIST STEP OPTIONS:
SHORT DRIVER AND SHORT FRONT-PASSENGER SIDES;
SHORT DRIVER AND LONG FRONT-PASSENGER SIDES**

BROADEST V-8 ENGINE LINEUP IN THE SEGMENT

DURAMAX 6.6L V-8 IS THE MOST POWERFUL DIESEL ENGINE IN ITS CLASS (AVAILABLE)

5-PASSENGER CREW VAN SEATING (AVAILABLE)

120-VOLT POWER OUTLET





SAVANA 3500 CARGO VAN IN SUMMIT WHITE
shown with available equipment.

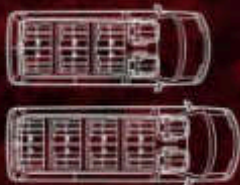

NEW DNSTAR 4G LTE WITH
WI-FI HOTSPOT¹ (AVAILABLE)

NEW COLOR TOUCH NAVIGATION
RADIO WITH INTELLILINK²
(AVAILABLE)

BROADEST V-8 ENGINE
LINEUP IN THE SEGMENT

HEAD CURTAIN SIDE-IMPACT
AIR BAGS³ HELP PROVIDE
PROTECTION FOR THE FIRST
THREE ROWS

ASSIST STEP OPTIONS:
SHORT DRIVER AND LONG
FRONT-PASSENGER

EXTENDED WHEELBASE MODELS
FEATURE THREE-LAYER SPECIAL-
TECHNOLOGY GLASS FOR THE
FOURTH AND FIFTH ROWS

120-VOLT POWER OUTLET



SAVANA 3500 PASSENGER VAN IN ONYX BLACK⁴
shown with available equipment.

SAVANA PASSENGER VAN

SAFETY ISN'T JUST A PRIORITY. IT'S YOUR BUSINESS.

We understand "safety first." Our Savana Passenger Vans include new seat-mounted side-impact air bags.² They help protect the thorax and pelvis of the driver and front passenger in a side-impact collision, while head curtain side-impact air bags³ help protect people in the front rows. On Extended Wheelbase models, enhanced-technology glass in the rearmost side windows helps protect everyone in the fourth and fifth rows. Savana also includes StabiliTrak and ABS. It can also accommodate mobility equipment such as wheelchair lifts, ramps, running boards and other driver aids, available from independent aftermarket suppliers.⁴

INTELLILINK² Included with available Color Touch Navigation,⁵ IntelliLink provides smartphone integration and voice-activated control of your communication and entertainment selections, including placing a call, changing stations, streaming Internet radio stations Pandora and Stitcher™ SmartRadio or accessing your music library. It also converts text messages into voice messages.

MULTIPLE PASSENGER CONFIGURATIONS With two wheelbase choices, two model series and two seating arrangements, Savana Passenger Vans can accommodate 12 people in 2500 and 3500 Series 135" wheelbase models or up to 15 in the 3500 Series 155" wheelbase models.



¹Devices must be WPA2-compliant with active OnStar service and data plan. Wi-Fi devices manufactured prior to 2006 may not be compatible. Please consult your device manufacturer for information regarding the WPA2 security protocol and Wi-Fi device compatibility. Vehicle must be started or in accessory mode to access Wi-Fi. Visit onstar.com for details and system limitations. ²Full functionality requires compatible Bluetooth and smartphone. Some devices require USB connectivity. Data plan rates apply. ³Always use safety belts and the correct child restraint for your child's age and size, even with air bags. Even in vehicles equipped with the Passenger Sensing System, children are safer when properly secured in a rear seat in the appropriate infant, child or booster seat. Never place a rear-facing infant restraint in the front seat of any vehicle equipped with an active frontal air bag. See your vehicle Owner's Manual and child safety seat instructions for more safety information. ⁴Equipment added by an independent supplier. See page 47 for information about alterations and warranties. Reimbursement plans are available. See dealer for details or go to gmaccessibility.com. ⁵Map coverage available in the United States, U.S. Virgin Islands, Puerto Rico and Canada.

SAVANA 3500 CARGO VAN IN SUMMIT WHITE
shown with available equipment.



AVAILABLE IN 139", 159"
AND 177" WHEELBASES

A LARGE RANGE OF GVWRs:
9900-12,300 LBS (139"
WHEELBASE), 9900-14,200
LBS (159" WHEELBASE)
AND 12,300-14,200 LBS
(177" WHEELBASE)†

COLOR TOUCH NAVIGATION*
SYSTEM WITH INTELLILINK®
[AVAILABLE]

AVAILABLE AUTOMATIC
LOCKING REAR
DIFFERENTIAL IMPROVES
LOW-SPEED TRACTION

SAVANA 3500 CUTAWAY WITH DUAL REAR WHEELS*
shown with available equipment.



SAVANA CUTAWAY

ADAPTS TO YOUR NEEDS. EXCEEDS YOUR EXPECTATIONS.

Savana Cutaway can be upfitted for various commercial applications. With a combination of remarkable payload and GVWR, along with three wheelbase lengths and dual- and single-rear-wheel options, it's the perfect solution for your needs. Opt for the 57-gallon fuel tank [approx.], available with a gas V-8 and standard with a diesel V-8, and even refueling won't slow you down.

STABILITRAK Works with Traction Control to help maintain control when driving on ice, snow, gravel, wet pavement and uneven roads. Standard on SRW models only.

EATON® AUTOMATIC LOCKING REAR DIFFERENTIAL When the available Eaton locker senses a 100 rpm difference in wheel speed between the left and right rear wheels, it locks both to turn in unison for added traction.

SAVANA MOBILE OFFICE Available features such as Bluetooth® and available OnStar 4G LTE Wi-Fi² along with a new 110-volt outlet, turn Savana into a fully functional mobile office.



CUTAWAY SCHOOL BUS¹



CUTAWAY SHUTTLE BUS¹



CUTAWAY WITH AMBULANCE BODY¹



CUTAWAY WITH UTILITY BOX¹

SAVANA 3500 CUTAWAY WITH DUAL REAR WHEELS¹ shown with available equipment.

¹When properly equipped. Includes weight of vehicle, passengers, cargo and equipment. ²Map coverage available in the United States, U.S. Virgin Islands, Puerto Rico and Canada. ³Full functionality requires compatible Bluetooth and smartphone. Some devices require USB connectivity. ⁴Equipment added by an independent supplier. See page 47 for information about alterations and warranties. Reimbursement plans are available. See dealer for details or go to gm.mobility.com. ⁵Go to my.gmc.com/learn to find out which phones are compatible with the vehicle. ⁶Devices must be WPA2-compliant with active OnStar service and data plan. Wi-Fi devices manufactured prior to 2006 may not be compatible. Please consult your device manufacturer for information regarding the WPA2 security protocol and Wi-Fi device compatibility. Vehicle must be started or in accessory mode to access Wi-Fi. Visit onstar.com for details and system limitations.

S = Standard A = Available -- = Not Available

PASSENGER						CARGO							
ENGINE AVAILABILITY	SAE NET HP @ RPM	TORQUE (LB-FT) @ RPM	2500 RWD	3500 RWD	3500 Ext RWD	ENGINE AVAILABILITY	SAE NET HP @ RPM	TORQUE (LB-FT) @ RPM	2500 RWD	2500 Ext RWD	3500 RWD	3500 Ext RWD	
Vortec 4.8L V-8	295 @ 5400	295 @ 4600	S	S	S	Vortec 4.8L V-8	295 @ 5400	295 @ 4600	S	S	S	S	
Vortec 6.0L FlexFuel V-8	342 @ 5400	373 @ 4400	A	A	A	Vortec 6.0L FlexFuel V-8	342 @ 5400	373 @ 4400	A	A	A	A	
Duramax 6.6L V-8 Turbo Diesel	300 @ 3700	525 @ 1900	--	A	A	Duramax 6.6L V-8 Turbo Diesel	300 @ 3700	525 @ 1900	A	A	A	A	
Vortec 6.0L CNG V-8	282 @ 4800	320 @ 4400	--	--	--	Vortec 6.0L CNG V-8	282 @ 4800	320 @ 4400	A	A	A	A	
TRANSMISSION						TRANSMISSION							
6-Speed Automatic			S	S	S	6-Speed Automatic			S	S	S	S	
CAPACITY						CAPACITY							
GVWR (lbs) ¹			8000	9600	9600 ²	GVWR (lbs) ¹			8000	9600	9600	9600 ²	
Front GAWR (lbs)			4100	4300	4300	Front GAWR (lbs)			4100	4100	4300	4300	
Rear GAWR (lbs)			5360	6084	6084	Rear GAWR (lbs)			5360	5360	6084	6084	
Maximum Payload (lbs) ³			2482	3401	3142	Maximum Payload (lbs) ³			3247	3073	4120	3839	
PASSENGER VAN DOOR AND SEATING CONFIGURATIONS						CARGO VAN DOOR CONFIGURATIONS							
Right-Hand Passenger Side 60/40 Swing-Out Doors			S	S	S	Right-Hand 60/40 Swing-Out Cargo Doors			S	S	S	S	
Right-Hand Passenger Side Sliding Door			A	A	A	Right-Hand Sliding Door			A	A	A	A	
Rear Swing-Out Doors			S	S	S	Rear Swing-Out Cargo Doors			S	S	S	S	
8-Passenger Seating			A	A	--	Savana Pro Side Access Panels			A	--	A	--	
12-Passenger Seating			S	S	S	5-Passenger Seating			A	A	A	A	
15-Passenger Seating			--	--	A								
MAX TRAILERING		2500		3500		2500		2500		2500		2500	
Wheelbase		135"		135"		135"		135"		135"		135"	
Engine		4.8L V-8	6.0L CNG V-8	4.8L V-8	6.0L V-8	Duramax 6.6L V-8 Turbo Diesel	4.8L V-8	6.0L V-8	6.0L CNG V-8	Duramax 6.6L V-8 Turbo Diesel	4.8L V-8	6.0L V-8	6.0L CNG V-8
Axle Ratio		3.42	3.42	3.42	3.42	3.54	3.42	3.42	3.42	3.54	3.42	3.42	3.42
Maximum Trailer Weight ⁴		8100	9600	9600	8100	9700	10,000	9700	8100	10,000	9700	10,000	10,000
PASSENGER						CARGO							
DIMENSIONS		135" WHEELBASE			155" WHEELBASE			135" WHEELBASE			155" WHEELBASE		
Overall Length (in.)		224			244			224			244		
Overall Width (in.)		79.2			79.2			79.2			79.2		
Overall Height (in.) ⁵		83.9 (2500) / 83.7 (3500)			82.9			84.6 (2500) / 84.5 (3500)			84.3 (2500) / 84.1 (3500)		
Side Door Height (in.)		47.9			47.9			47.9			47.9		
Side Door Width (in.)		44.7			44.7			45.3			45.3		
Rear Door Opening Width (in.)		67			67			67			67		
Rear Door Opening Height (in.)		49.4			49.4			49.4			49.4		
Max Cargo Space (cu. ft.) ⁶ with seats removed		216.2			252.9			270.4			313.9		
Fuel Tank Capacity in Gallons (approx.)		31			31			31			31		
Wheels (in.) 2500/3500 only		16			16			16			16		

SAVANA PASSENGER VAN



2500 | 135" WB | RWD



3500 | 135" WB | RWD



3500 | 155" WB | RWD

SAVANA CARGO VAN



2500 | 135" WB | RWD



2500 | 155" WB | RWD



3500 | 135" WB | RWD



3500 | 155" WB | RWD

SAVANA 3500 SERIES CUTAWAY



139" WB | RWD



159" WB | RWD

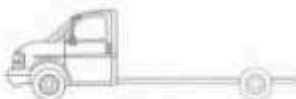

177" WB | RWD

SAVANA 4500 SERIES CUTAWAY

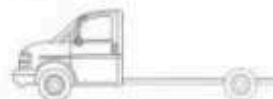

159" WB | RWD



177" WB | RWD

Wheelbase		139"	159"	177"
ENGINE AVAILABILITY	SAE NET HP @ RPM	TORQUE (LB-FT) @ RPM		
Vortec 4.8L V-8 (GVWR < 10,000 lbs)	295 @ 5400	295 @ 4600	S	A
Vortec 4.8L V-8 (GVWR > 10,000 lbs)	295 @ 5400	295 @ 4600	S	S
Vortec 6.0L FlexFuel ¹ V-8	342 @ 5400	370 @ 4400	A	S ²
Duramax 6.6L V-8 Turbo Diesel	250 @ 3700	525 @ 1800	A	A
TRANSMISSION				
6-Speed OD Automatic			S	S
CAPACITY				
GVWR (lbs) ³		9900-12,300	8900-14,200	12,300-14,200
Front GAWR (lbs)		4700-4600	4700-4600	4600
Rear GAWR (lbs)		6084-9500	6084-9500	8600-9500
Base Payload (lbs) ⁴		See gmfleet.com and click on the Body Application Guide.		

¹E85 FlexFuel capability is not available in AZ, CA, CT, DE, MA, MD, ME, NJ, NY, OR, PA, RI, VT and WA. E85 is a combination of 85% ethanol and 15% gasoline. Go to eflex.com to see if there is an E85 fuel station near you. ²When properly equipped includes weight of vehicle, passengers, cargo and equipment. ³GVWR with Duramax Diesel is 9900 lbs. ⁴These maximum payload ratings are intended for comparison purposes only. Before you buy a vehicle or use it to haul people or cargo, carefully review the vehicle loading section of the Owner's Manual and check the carrying capacity of your specific vehicle on the label on the inside of the driver's door jamb. Before you buy a vehicle or use it for trailering, carefully review the trailering section of the Owner's Manual. The weight of passengers, cargo and options or accessories may reduce the amount you can tow. ⁵Includes antennas. ⁶Cargo and load capacity limited by weight and distribution. ⁷Available on Savana 4500 Series, available on Savana 3500 Series.



YUKON

TREAT YOUR PASSENGERS TO A LUXURY SUITE.

At GMC, designing and engineering the 2016 Yukon and Yukon XL meant creating a new definition of the premium Professional Grade SUV, as well as satisfying businesses that demand a higher level of comfort, entertainment and performance. Yukon combines two powerful, efficient EcoTec3 engines and the quietest Yukon ever—quiet enough to hear your passengers' every request—with a spacious interior that's loaded with premium materials, innovative safety technologies and ingenious voice-activated infotainment systems. You and your passengers will appreciate the attention we've given to every detail of the driving experience.

QUIETLY WHISPERS PREMIUM Yukon and Yukon Denali raise the standards for solitude. You'll enjoy the quietest Yukon ever. In Yukon Denali (shown), premium surroundings abound thanks to authentic materials, a Bose® Centerpoint® surround sound system and an available four-color Head-Up Display.



NEW FOR 2016 IS SUPPORT FOR APPLE CARPLAY.™¹ IT'S THE SMARTER WAY TO USE YOUR IPHONE® INSIDE YOUR YUKON

WIRELESS CHARGING MAT ON SELECT DENALI AND SLT MODELS²

ONSTAR WITH 4G LTE AND BUILT-IN WI-FI HOTSPOT³ (AVAILABLE)

DRIVER ALERT PACKAGE NOW INCLUDES LANE KEEP ASSIST AND INTELLIBEAM (AVAILABLE)

CLASS-LEADING POWER WITH THE ECOTEC3 5.2L V-8 (DENALI)

EXCEPTIONAL FUEL EFFICIENCY* WITH THE ECOTEC3 5.3L V-8

POWER-RELEASE FOLD-AND-TUMBLE SECOND-ROW AND POWER FOLD-FLAT THIRD-ROW SEATS (AVAILABLE)

YUKON XL DENALI IN ONYX BLACK (shown with available equipment)

¹Vehicle user interface is a product of Apple® and Apple's® terms and privacy statements apply. Requires compatible smartphone. Data plan rates apply. ²The vehicle must be on or Retained Accessory Power must be active. Remove all objects from the charging pad. Place the mobile device face up on the charging symbol on the charging pad. Move the device slowly until the battery charging symbol displays on the touch-screen, indicating the device is charging. See your Infotainment System Owner's Manual. ³Devices must be WPA2-compliant with active OnStar service and data plan. Wi-Fi devices manufactured prior to 2006 may not be compatible. Please consult your device manufacturer for information regarding the WPA2 security protocol and Wi-Fi device compatibility. Vehicle must be started or in accessory mode to access Wi-Fi. Visit onstar.com for details and system limitations. *EPA-estimated mpg for 5.3L EcoTec3 engine: 16 city/23 hwy [2WD], 16 city/22 hwy [4WD].

ACADIA, THE ULTIMATE MULTITASKER.

In business, versatility is the key to success. That's why we engineered Acadia to provide the cargo capacity of a full-size SUV with the benefits of crossover-like ease of entry and exceptional highway gas mileage.¹ To help you accomplish more, Acadia offers available OnStar 4G LTE Wi-Fi.² Gain fast internet speeds by adding an available Wi-Fi hotspot to your mobile office. Acadia's spacious interior is easily configured with just one hand, allowing you to strike a balance between seating up to eight and 116.1 cu. ft. of maximum cargo space.³ The 3.6L VVT engine offers impressive power in addition to a one-tank maximum highway driving range of up to 528 miles.⁴

A ONSTAR WITH 4G LTE AND BUILT-IN WI-FI HOTSPOT² OnStar with 4G LTE and an available built-in Wi-Fi hotspot includes a 3-month or 3GB data trial (whichever comes first) for a fast internet connection for Web-enabled devices. It's reliable, easy to use and can connect up to seven mobile devices.

B CONFIGURABLE INTERIOR An adaptable interior helps balance your passenger and cargo needs. Fold the second and third rows to create a flat area for convenient loading.

C SMART SLIDE SEATING With Smart Slide second-row seating, you can slide the seats to the forward-most position with one hand. You can compact them for space with the same motion as a chaise lounge.



A



B

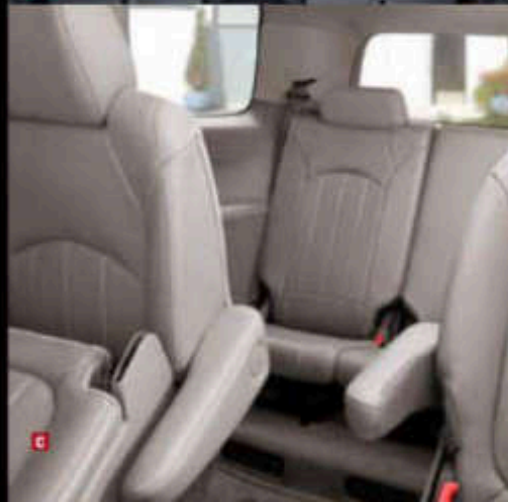

C

NEW ONSTAR WITH 4G LTE
AND BUILT-IN WI-FI HOTSPOT²
(AVAILABLE)

MORE CARGO VOLUME BEHIND
THE THIRD ROW THAN ANY
COMPETITOR¹

CONVENIENT ONE-HAND
OPERATION FOR FLAT-FOLDING
SECOND- AND THIRD-ROW SEATS

TRI-ZONE CLIMATE CONTROL
SYSTEM ACCOMMODATES
THIRD-ROW PASSENGERS
(AVAILABLE)

¹EPA-estimated mpg: 17 city/24 hwy (240), 16 city/23 hwy (AWD). ²Devices must be WPA2-compliant with active OnStar service and data plan. Wi-Fi devices manufactured prior to 2006 may not be compatible. Please consult your device manufacturer for information regarding the WPA2 security protocol and Wi-Fi device compatibility. Vehicle must be started or in accessory mode to access Wi-Fi. Visit onstar.com for details and system limitations. ³Cargo and load capacity limited by weight and distribution. ⁴Based on EPA-estimated 24 hwy mpg (FWD) and fuel tank capacity. Your range may be less.



ACADIA SLT IN CRIMSON RED TINTCOAT
shown with available equipment.



TERRAIN SLT IN CARBON BLACK METALLIC
shown with available equipment

TERRAIN

MOBILE WORK SPACE FOR
A MOBILE WORKFORCE.

The productivity of your business matters to us. Make Terrain part of your fleet and reap the benefits of a tech-savvy crossover. Available communication technologies include IntelliLink[®] and OnStar with 4G LTE[®] and an available built-in Wi-Fi hotspot that allow your workforce to stay connected. Intelligent safety technologies such as the available Forward Collision Alert and Lane Departure Warning help make navigating safer. Plus, Side Blind Zone Alert and Rear Cross Traffic Alert are available on a wider range of trim levels for 2016. Smart engineering results in head room and leg room rivaling that of a full-size SUV while offering an EPA-estimated 32 mpg highway. Innovative Multi-Flex seating lets you configure the interior to choose between Terrain's client- and customer-pleasing 39.9" of second-row leg room or 31.6 cu. ft. of cargo² space behind the second row.

A INTELLILINK[®] Available IntelliLink uses Bluetooth[®] or USB² to connect the driver's smartphone to Terrain's 7" diagonal Color Touch Radio. It provides voice activation and hands-free calling and has steering-wheel-mounted controls to operate your smartphone.

B ROOM FOR EVERYONE—AND EVERYTHING Terrain complements its generous passenger room with smart storage solutions to help you make the most of your cargo space.

UP TO 600-MILE MAXIMUM
HIGHWAY CRUISING RANGE
ON FWD 1-4 MODELS¹

ALL-WHEEL-DRIVE MODELS
OFFER BEST-IN-CLASS AWD
HIGHWAY CRUISING RANGE¹

UP TO 63.9 CUBIC FEET
OF CARGO SPACE²

TERRAIN HAS THE HEAD
ROOM AND LEG ROOM OF
A FULL-SIZE SUV

¹Range based on EPA-estimated 32 hwy mpg (FWD) and fuel tank capacity. Your range may be less. ²Range based on EPA-estimated 29 hwy mpg (AWD) and fuel tank capacity. Your range may be less. ³Cargo and load capacity limited by weight and distribution. ⁴For functionality requires compatible Bluetooth and smartphone. Some devices require USB connectivity. ⁵Devices must be WPA2-compliant with active OnStar service and data plan. Wi-Fi devices manufactured prior to 2006 may not be compatible. Please consult your device manufacturer for information regarding the WPA2 security protocol and Wi-Fi device compatibility. Vehicle must be started or in accessory mode to access Wi-Fi. Visit onstar.com for details and system limitations. ⁶Go to my.gmc.com/learn to find out which phones are compatible with the vehicle. ⁷Not compatible with all devices.

S = Standard A = Available -- = Not Available			YUKON		YUKON XL		YUKON DENALI		YUKON XL DENALI	
ENGINE AVAILABILITY	SAE NET HP @ RPM	TORQUE (LB-FT) @ RPM	2WD	4WD	2WD	4WD	2WD	4WD	2WD	4WD
5.3L EcoTec3 V-8 (325 cu. in.)	365 @ 5600	383 @ 4100	S	S	S	S	-	-	-	-
6.2L EcoTec3 V-8 (376 cu. in.)	420 @ 5600	460 @ 4100	-	-	-	-	S	S	S	S
TRANSMISSION										
6-Speed Automatic			S	S	S	S	-	-	-	-
9-Speed Automatic			-	-	-	-	S	S	S	S
AXLE RATIO										
3.08:1			S	S	S	S	-	-	-	-
3.23:1			-	-	-	-	S	S	S	S
3.42:1			A	A	A	A	-	-	-	-
CAPACITY										
GVWR (lbs) ¹			7000	7300	7300	7600	7900	7300	7300	7600
Front GAWR (lbs)			3200	3600	3500	3800	3200	3600	3500	3800
Rear GAWR (lbs)			4000	4200	4400	4400	4300	4300	4300	4300
Max Payload (lbs) ²			1762	1715	1633	1606	1576	1517	1551	1492
MAX TRAILERING										
Engine			5.3L EcoTec3	5.3L EcoTec3	5.3L EcoTec3	5.3L EcoTec3	6.2L EcoTec3	6.2L EcoTec3	6.2L EcoTec3	6.2L EcoTec3
Axle Ratio (2WD/4WD)			3.42	3.42	3.42	3.42	3.23	3.23	3.23	3.23
Maximum Trailer Weight ³			8500	8200	8300	8000	8400	8100	8100	7900
DIMENSIONS			YUKON		YUKON XL		YUKON DENALI		YUKON XL DENALI	
Wheelbase (in.)			116.0		130.0		116.0		130.0	
Overall Length (in.)			203.9		224.3		203.5		224.3	
Overall Height (in.)			74.4		74.4		74.4		74.4	
Overall Width (in.)			80.5		80.5		80.5		80.5	
Fuel Tank Capacity in Gallons (approx.)			26.0		31.0		26.0		31.0	
Standard Wheels (in.)			18		18		20		20	

¹When properly equipped. Includes weight of vehicle, passengers, cargo and equipment. ²These maximum payload ratings are intended for comparison purposes only. Before you buy a vehicle or use it to haul people or cargo, carefully review the vehicle loading section of the Owner's Manual and check the carrying capacity of your specific vehicle on the label on the inside of the driver's door jamb. ³Before you buy a vehicle or use it for trailering, carefully review the trailering section of the Owner's Manual. The weight of passengers, cargo and options or accessories may reduce the amount you can tow. ⁴Cargo and load capacity limited by weight and distribution.

YUKON/YUKON DENALI



2WD | 4WD

YUKON XL/YUKON XL DENALI



2WD | 4WD

S = Standard A = Available -- = Not Available

	ACADIA/ACADIA DENALI	
	FWD	AWD
ENGINE AVAILABILITY		
3.6L V-6 SIDI VVT	S	S
TRANSMISSION		
8-Speed Automatic, Electronically Controlled with OD	S	S
AXLE RATIO		
3.16:1	S	S
CAPACITY		
GWR (lbs) ¹	6411	6419
Payload (lbs) ²	1415-1755	1250-1600
MAX TRAILERING		
Engine	3.6L V-6 SIDI VVT	3.6L V-6 SIDI VVT
Axle Ratio	3.16	3.16
Maximum Trailer Weight ³	5200	5200
DIMENSIONS		
Wheelbase (in.)	118.9	118.9
Overall Length (in.)	200.8	200.8
Overall Height (in.) With Roof Rails	72.6	72.6
Overall Width (in.) Without Mirrors	78.9	78.9
Fuel Tank Capacity in Gallons (approx.)	22.0	22.0
Standard Wheels (in.)	18	18
Head Room (first row) (in.)	40.3	40.3
Leg Room (first row) (in.)	41.3	41.3
Shoulder Room (first row) (in.)	61.6	61.6
Hip Room (first row) (in.)	58.0	58.0
Cargo Volume Behind First Row (cu. ft.) ⁴	116.1	116.1
Cargo Volume Behind Second Row (cu. ft.) ⁴	70.1	70.1
Cargo Volume Behind Third Row (cu. ft.) ⁴	24.1	24.1

ACADIA/ACADIA DENALI



FWD | AWD

S = Standard A = Available -- = Not Available

ENGINE AVAILABILITY	SAE NET HP @ RPM	TORQUE (LB-FT) @ RPM	TERRAIN		TERRAIN DENALI	
			FWD	AWD	FWD	AWD
2.4L I-4 SIDI	152 @ 6700	170 @ 4900	S	S	S	S
3.6L V-6 SIDI	301 @ 6500	272 @ 4800	A	A	A	A
TRANSMISSION						
6-Speed D3 Automatic			S	S	S	S
AXLE RATIO						
2.77:1			A	-	A	-
3.23:1			S	-	S	-
3.39:1			-	A	-	A
3.53:1			-	S	-	S
CAPACITY						
Engine			2.4L I-4/3.6L V-6	2.4L I-4/3.6L V-6	2.4L I-4/3.6L V-6	2.4L I-4/3.6L V-6
Drivetrain			FWD	AWD	FWD	AWD
GWR (lbs) ¹			4960/5200	5075/5300	4960/5200	5075/5300
Front GAWR (lbs)			2590/2755	2590/2755	2590/2755	2590/2755
Rear GAWR (lbs)			2733/2733	2733/2621	2733/2733	2733/2621
Base Payload (lbs) ²			1107/1165	1050/1182	1075/1164	1021/1098
MAX TRAILERING						
Engine			2.4L I-4/3.6L V-6	2.4L I-4/3.6L V-6	2.4L I-4/3.6L V-6	2.4L I-4/3.6L V-6
Axle Ratio			3.23/2.77	3.53/3.39	3.23/2.77	3.53/3.39
Maximum Trailer Weight ³			1500/3500	1508/3500	1500/3500	1500/3500
DIMENSIONS						
Wheelbase (in.)			112.5	112.5	112.5	112.5
Overall Length (in.)			185.5	185.5	185.5	185.5
Overall Height (in.) Without Luggage Rack			66.3	66.3	66.3	66.3
Overall Width (in.) Without Mirrors			72.8	72.8	72.8	72.8
Fuel Tank Capacity in Gallons (I-4/V-6) (approx.)			18.8/20.9	18.8/20.9	18.8/20.9	18.8/20.9
Head Room (first row) (in.)			39.8	39.8	39.8	39.8
Leg Room (first row) (in.)			41.2	41.2	41.2	41.2
Shoulder Room (first row) (in.)			55.7	55.7	55.7	55.7
Hip Room (first row) (in.)			55.1	55.1	55.1	55.1
Cargo Volume Behind First Row (cu. ft.) ⁴			63.9	63.9	63.9	63.9
Cargo Volume Behind Second Row (cu. ft.) ⁴			31.6	31.6	31.6	31.6

¹When properly equipped, includes weight of vehicle, passengers, cargo and equipment. ²These maximum payload ratings are intended for comparison purposes only. Before you buy a vehicle or use it to haul people or cargo, carefully review the vehicle loading section of the Owner's Manual and check the carrying capacity of your specific vehicle on the label on the inside of the driver's door jamb. ³Before you buy a vehicle or use it for trailering, carefully review the trailering section of the Owner's Manual. The weight of passengers, cargo and options or accessories may reduce the amount you can tow. ⁴Cargo and load capacity limited by weight and distribution.

TERRAIN/TERRAIN DENALI



FWD | AWD

GOOD FOR BUSINESS. Whether you need to meet company-wide environmental initiatives or government standards, GMC offers alternative fuels for Savana and Sierra HD. Savana's Compressed Natural Gas (CNG) systems are designed for both low emissions and low operating costs. Sierra HD can be equipped with our new CNG/Gasoline Bi-Fuel System, helping your organization reduce costs and environmental impact.

ALTERNATIVE FUELS AVAILABILITY (see your dealer for more details)

VEHICLE	CNG	CNG BI-FUEL	E85 ¹	B20
Sierra	—	A	A	A
Savana	A	—	A	A
Canyon	—	—	—	A
Yukon	—	—	—	—
Acadia	—	—	—	—
Terrain	—	—	A ²	—

A = Available — = Not Available

¹E85 FlexFuel capability is not available in AZ, CA, CT, DE, MA, MD, ME, NJ, NY, OR, PA, RI, VT and WA. E85 is a combination of 85% ethanol and 15% gasoline. Go to efuel.energy.gov/efuel/fuels to see if there is an E85 fuel station near you. ²Limited availability. Only available in federal emissions states. ³Based on GM testing and fuel tank capacity. Your range may be less.

CNG Dedicated CNG systems are available on Savana Cargo/Passenger Vans. CNG vehicles are equipped with a specially designed 6.0L Vortec engine built for gaseous fuel, along with an integrated and warranted dedicated gaseous fuel system in place.

3- OR 4-TANK SYSTEM CNG-equipped Savanas can be outfitted with either a 3-tank or an extended-range 4-tank system. Both systems are designed to maximize efficiency while minimizing obstruction in the cargo area.

BI-FUEL GAS/CNG SYSTEM Our proven 6.0L Vortec V-8 forms the core of Sierra HD's CNG/Gasoline Bi-Fuel System (select models only). Enhanced with hardened exhaust valves and intake/exhaust seats, an in-bed CNG tank and an extensively protected fuel system, the Bi-Fuel System provides a maximum highway range of up to 625 miles.³ Sierra also offers excellent payload capacity—helping businesses reduce costs and environmental impact. GMC's Limited Warranty covers the CNG fuel delivery and storage system, providing you with peace of mind that parts will be available to keep you on the road. See your dealer for details and model availability.



GMC ACCESSORIES

Helping you do your job even better. Customize your GMC to fit your business needs. Every one of our accessories lives up to the GMC name and helps you take on the challenges of your business.



GMC BUSINESS CHOICE

GMC Business Choice is an incentive program designed for business owners like you who rely on their vehicles for their day-to-day operations. It's available when you purchase or lease an eligible, new GMC vehicle, and it offers several options, including the GM Accessory or Upfit Cash Allowance.

For complete program requirements, including information regarding offers, vehicles, equipment, options, warranties and ordering information, consult with your GMC dealer, or visit gmbusinesschoice.com.



FLEET SERVICES

You're the business, we're the dealership. In the coast-to-coast Business Elite network, each dealership is dedicated to helping you find the right vehicles for just about any job. They'll meet with you at your convenience. And every Business Elite dealership offers service facilities specialized to keep your work vehicles operating at peak performance and efficiency, helping you better serve your customers. Your Business Elite dealership has the widest selection of vehicles to fit your business needs, from the Sierra family of full-size pickups to the full line of Savana Vans, plus a wide range of work-ready vehicles to meet your needs. To find a Business Elite dealership near you, go to gmfleet.com/businesselite.



For additional Fleet & Commercial information, visit gmfleet.com.

GMC BUSINESS ELITE

Business Elite dealers provide you with a team of expert sales account specialists to help you select the right vehicles for the job. They stock a diverse lineup of vehicles that are ready for sale at a moment's notice. Plus, every Business Elite service department has the facilities, tools, equipment and certified technicians to help maintain your vehicle fleet.



Learn more about both of these programs at gmfleet.com.

GMC'S COMMITMENT GMC is committed to offering your business a hassle-free trucking experience that includes a limited warranty and a strong network of GMC dealers who are ready to answer your questions, provide authorized service, maintain a large stock of Genuine GM Parts and accessories and give you access to GMC factory personnel. For help and information, call 1-800-GMC-8782.

We have tried to make this catalog comprehensive and factual. We reserve the right, however, to make changes at any time, without notice, in prices, colors, materials, equipment, specifications, models and availability. **Specifications, dimensions, measurements, ratings and other numbers in this catalog and other printed materials provided at the dealership or affixed to vehicles are approximates based upon design and engineering drawings, prototypes and laboratory tests. Your vehicle may differ due to variations in manufacture and equipment.** Since some information may have been updated since the time of printing, please check with your GMC dealer for complete details. GMC reserves the right to lengthen or shorten the model year for any product for any reason or to start and end model years at different times. All competitive claims are based on the latest information available at the time of printing.

CORROSION PROTECTION GMC vehicles are designed and built to resist corrosion. All body and sheet metal components are warranted against rust-through corrosion for 5 years/100,000 miles (whichever comes first). Application of additional rust-inhibiting materials is not required under the corrosion coverage and none is recommended. See your GMC dealer for terms of this limited warranty.

AN IMPORTANT NOTE ABOUT ALTERATIONS AND WARRANTIES Installations or alterations to the original-equipment vehicle (or chassis) as distributed by General Motors are not covered by the General Motors New-Vehicle Limited Warranty. The special body company, assembler, equipment installer or upfitter is solely responsible for warranties on the body or equipment and any alterations (or any effect of the alterations) to any of the parts, components, systems or assemblies installed by GM. General Motors is not responsible for the safety or quality of design features, materials or workmanship of any alterations by such suppliers.

UPDATED SERVICE INFORMATION GMC dealers receive useful service bulletins about GMC products. You may purchase them from Helm Incorporated by calling 1-800-551-4123 or by visiting helminc.com.

ASSEMBLY GMC vehicles and their components are assembled or produced by different operating units of General Motors, its subsidiaries or suppliers to GM worldwide. We sometimes find it necessary to produce GMC vehicles with different or differently sourced components than originally scheduled. Since some options may be unavailable when your vehicle is assembled, we suggest you verify that your vehicle includes the equipment you ordered and that, if there were changes, they are acceptable to you.

ENGINES GMC products are equipped with engines produced by GM Powertrain or other suppliers to GM worldwide. The engines in GMC products may also be used in other GM makes and models.

TRAILERING AND OFF-ROAD INFORMATION Please carefully review the Owner's Manual for important safety information about trailering or off-road driving in your vehicle.

BUYPOWER CARD* Now it's even easier to get into the GMC of your dreams. Every purchase gives you Earnings redeemable toward part or even all of a new GMC, Chevrolet, Buick or Cadillac. Every year, enjoy 5 percent Earnings on your first \$5,000 in purchases and 2 percent unlimited Earnings after that. No expiration on Earnings and no limit on how much you can earn or redeem. Learn more at buypowercard.com. **YOUR CARD IS THE KEY.™**



NEW-VEHICLE LIMITED WARRANTY All GMC light-duty vehicles come with a fully backed 5-year/60,000-mile transferable Powertrain Limited Warranty¹ with no deductible. GM vehicles registered in the USA are covered for 3 years or 36,000 miles.¹ See your dealer for more details. The complete vehicle is covered, including tires, towing to your nearest GMC dealership and cosmetic corrosion resulting from defects. Repairs will be made to correct any vehicle defect, and most warranty repairs will be made at no charge. In addition, rust-through corrosion will be covered for 6 years or 100,000 miles.¹ See dealer for details.

A NOTE ON CHILD SAFETY Always use safety belts and the correct child restraint for your child's age and size, even with air bags. Even in vehicles equipped with the Passenger Sensing System, children are safer when properly secured in a rear seat in the appropriate infant, child or booster seat. Never place a rear-facing infant restraint in the front seat of any vehicle equipped with an active frontal air bag. See your vehicle Owner's Manual and child safety seat instructions for more safety information.

IMPORTANT INFORMATION ABOUT ONSTAR Your GMC vehicle includes the OnStar Guidance Plan (trial does not include Hands-Free Calling minutes) for 6 months. OnStar services require vehicle electrical system (including battery), wireless service and GPS satellite signals to be available and operating for features to function properly. OnStar service required. OnStar acts as a link to existing emergency service providers. Not all vehicles may transmit all crash data. Visit onstar.com for coverage maps, details and system limitations. Services vary by model and conditions.

SIRIUSXM SATELLITE RADIO SiriusXM Satellite Radio² is standard on most GMC models. It includes 3 trial months of service. SiriusXM Satellite Radio makes your drive come alive with commercial-free music channels from virtually every genre, artist-dedicated channels, live performances and more. Tune in to live play-by-play from the biggest sports, exclusive entertainment from top personalities, compelling talk, hilarious comedy, world-class news, local traffic and weather and family-friendly programming. Welcome to the world of satellite radio. Visit siriusxm.com for details.

¹Whichever comes first. See dealer for limited warranty details. ²If you subscribe after your trial period, subscriptions are continuous until you call SiriusXM to cancel. See SiriusXM Customer Agreement for complete terms at siriusxm.com. Other fees and taxes will apply. All fees and programming subject to change. For more information about NavTraffic, visit siriusxm.com/navtraffic. For more information about Travel Link, visit siriusxm.com/travelink. XM satellite service is available only to those in the 48 contiguous USA and D.C.

©2015 General Motors. All rights reserved. GM, the GM logo, GMC, the slogans, emblems, vehicle model names, vehicle body designs and other marks appearing in this catalog are the trademarks and/or service marks of General Motors, its subsidiaries, affiliates or licensors. Facebook is a registered trademark of Facebook, Inc. Twitter is a registered trademark of Twitter, Inc. YouTube is a registered trademark of Google, Inc. Sirius, XM and all related marks and logos are trademarks of SiriusXM Radio, Inc. Apple, iPhone and Apple CarPlay are registered trademarks of Apple, Inc. For more information on GMC commercial vehicles, see your GMC dealer, call 1-800-GMC-8782 or visit gmc.com.

