

1994 GMC SONOMA



GMC
TRUCK

SONOMA

STRENGTH/FRAME AND SUSPENSION	4
POWER/ENGINES	6
SAFETY	10
ENVIRONMENT/INTERIOR	12

HOW TO BUILD YOUR SONOMA/OPTIONS	14
HOW TO BUILD YOUR SONOMA/TRIM LEVELS	16
HOW TO BUILD YOUR SONOMA/SPECIFICATIONS	18
COMMITMENT PLUS	20

SONOMA SLE 4X4 CLUB COUPE IN CHERRY RED METALLIC UPPER AND STEEL GRAY LOWER, SHOWN WITH AVAILABLE EQUIPMENT.



The scene: Max Grabowsky's mechanical repair and workshop in Detroit. A small truck, chain-driven by a one-cylinder gasoline engine, rolls out onto Woodward Avenue and joins the horse-drawn traffic – and a revolution. The introduction of trucks to America. The first of over nine decades of GMC Trucks. ■ For 1994 we introduce a new GMC Truck of

innovative intent: the new Sonoma pickup. A slipstream entity that not only forecasts the aesthetic future of the pickup truck, but reaches new levels of quality and performance in critical domains of structural strength and integrity, on- and off-road ride and control, noise suppression and ergonomic fitness. ■ If Max could have seen 92 years forward, he'd have been proud. We're satisfied knowing that you'll be impressed.

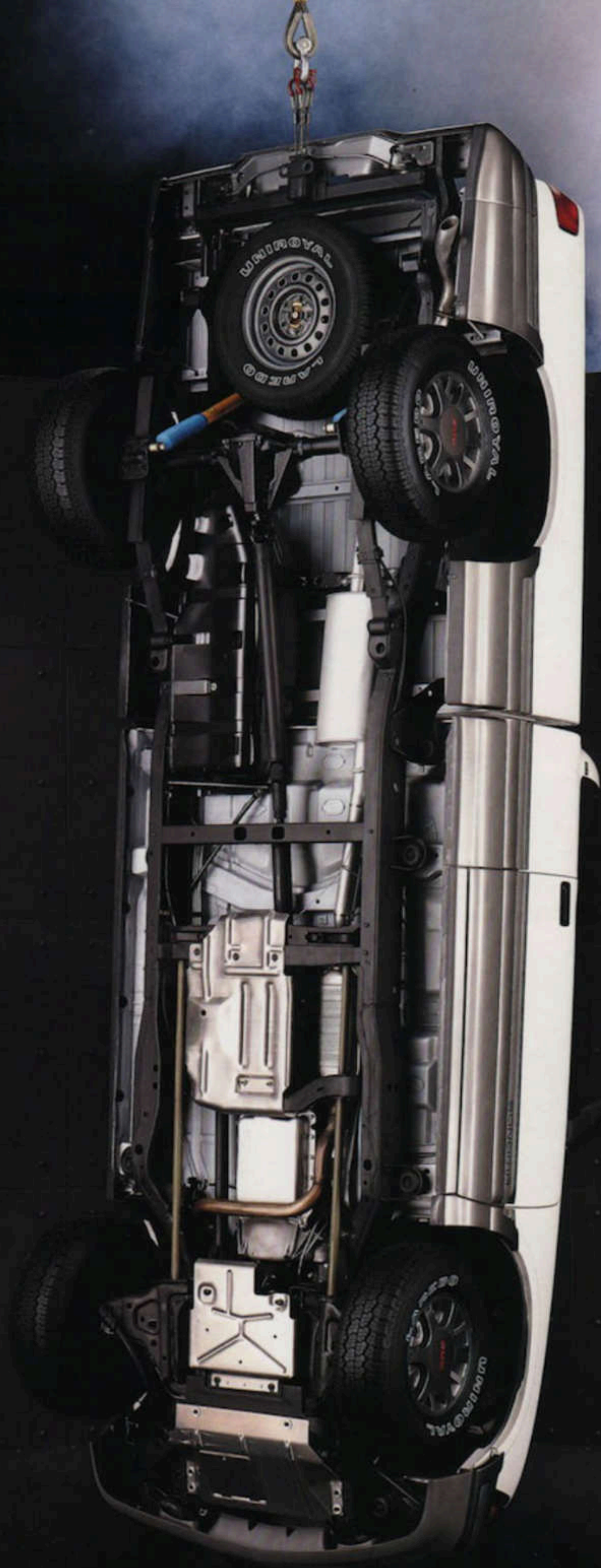

A STRONG FRAME IS THE FOUNDATION OF EVERY GMC TRUCK. IN SONOMA'S CASE, WE'VE GONE TO EXTREMES. THE NEW SONOMA HAS THE LARGEST BOXED FRAME

available on a pickup in its class. It's half again as stiff as the previous Sonoma overall; 28 percent more torsionally rigid. Naturally, it can handle a lot of payload – up to 1743 pounds.* ■ Equally significant is the choice of seven available suspension systems. For 2WD, there's one tuned to yield a smooth, solid highway ride, one that adds a razor's edge to handling and one for high payload. For 4x4, there's a solid highway

STRENGTH

ride, a high payload and two off-road packages, including the hot-looking

Highrider package. ■ So in addition to supreme capability, the new Sonoma also gives you a pickup truck tuned in to your particular passions, on the pavement or off.



DIVIDE AND CONQUER

TWO-STAGE MULTILEAF SPRINGS: LONG UPPER LEAVES HANDLE THE LOAD OF AN EMPTY BED; SHORTER, MORE RIGID INNER AND LOWER LEAVES FLEX AND SPRING UNDER PAYLOAD OR TRAILER WEIGHT.

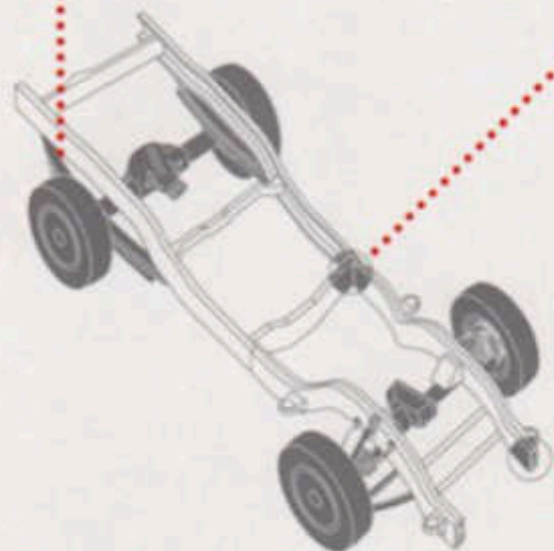

RESISTING TWISTING

C-CHANNEL RAILS AND CROSS-MEMBERS RESIST TORSIONAL TWISTING, FLEXING AND HORIZONTAL MISALIGNMENT TO HELP KEEP THE CAB AND BED TIGHT, TRACKING STRAIGHT.



STRONGBOX

PULLING A TRAILER CAN EASILY PULL A FRAME OUT OF ALIGNMENT, RESULTING IN CROOKED "DOGTRACKING." SONOMA'S BOXED FRONT END KEEPS YOU ON THE STRAIGHT AND NARROW.



*Properly equipped; includes passengers, cargo and equipment.

SONOMA 5

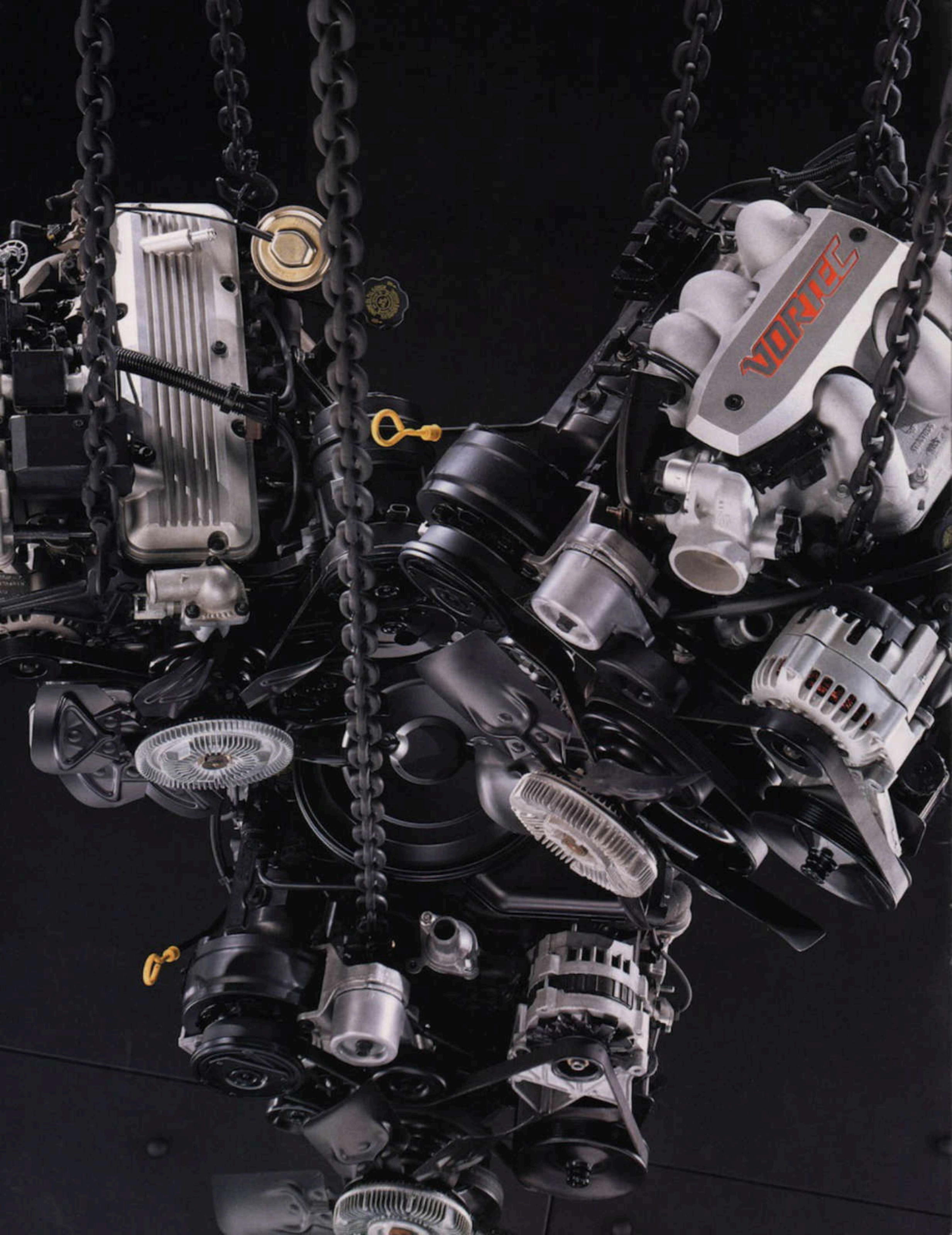

WE COULD TELL YOU THAT SONOMA IS AVAILABLE WITH AN ENGINE THAT PUTS IT AT THE UPPER BOUNDS OF POWER FOR ANY COMPACT OR MIDSIZE PICK-UP AND END THE DISCUSSION THERE. BUT THERE'S MUCH MORE TO HOLD YOUR ATTENTION IN

Sonoma's engine bay. ■ The available 262 c.i. (4.3L, if you've gone metric) V6 is throttle body-fuel injected (TBFi), for a fuel mix that burns more efficiently, the better to kick out more pure torque per unit of fuel – 235 lb-ft @ 2400 RPM, to be precise. The yield is 260 lb-ft of torque, not to mention 195 horses, from the available Enhanced V6. The look under the hood is clean and orderly, indicating an intelligent strength behind all that raw power. Your hand can get around with ease, and with tools. ■ Sonoma's new 133 c.i. (2.2L) 4-cylinder engine will give you a potent 130 lb-ft of torque off the line and 118 HP down the line. Not to mention a

POWER

precision firing pace managed by an electronic control module, and smooth, quiet performance thanks to dozens of improvements in engine mounting, componentry and sound management.

■ Whether you go with the standard four or one of the up-level sixes, these are clearly engines you'll want to take a stand on. By all means, do. We're sure you'll find the response consistently exhilarating.



SMOOTH PERFORMANCE

PISTON MASS IS REDUCED, INCREASING POWER DELIVERY AND REDUCING FRICTION WITH EACH STROKE. THIS ADDS PUNCH TO PERFORMANCE AT HIGHER RPM, WHILE HELPING TO QUIET THE ENGINE.



HEAT-RESISTING

THE VORTEC V6 ROCKER COVER IS MADE OF AN ADVANCED GLASS-FILLED POLYMER. IT RESISTS HEAT DEFORMATION FOR IMPROVED GASKET PERFORMANCE, AND CUTS ROCKER NOISE TRANSMISSION.



QUIET RIDE

WE'VE MADE THE AVAILABLE 262 c.i./4.3L VORTEC V6 A QUIET, SMOOTH PERFORMER. A BALANCE SHAFT BALANCES COMPONENT MOMENTUM WITHIN THE ENGINE, TO NEUTRALIZE VIBRATION AND NOISE.



CODED FOR COMFORT

STANDARDIZED COLOR-CODING OF OWNER-SERVICEABLE COMPONENTS MAKES SONOMA'S ENGINE BAY A PLACE WHERE YOU CAN ALMOST FEEL AT HOME.

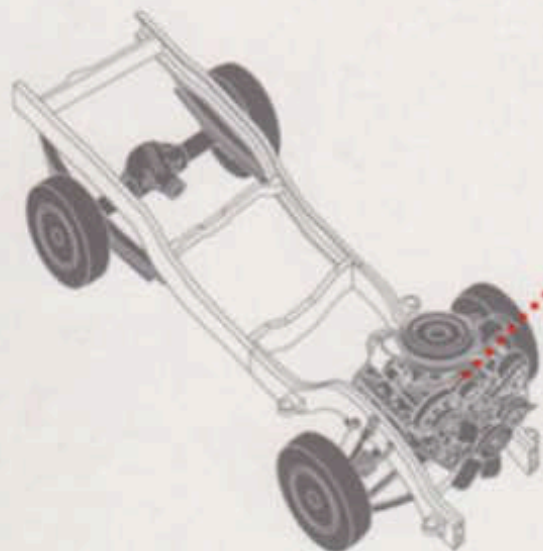



SONOMA SLS 4X4 HIGH RIDER IN BRILLIANT BLUE METALLIC, SHOWN WITH AVAILABLE EQUIPMENT.



SONOMA

GMC TRUCK

IF YOU COULD FORESEE ALL, YOU COULD AVOID ALL ACCIDENTS. WE CAN'T GIVE YOU POWERS OF PROPHECY, SO WE DO THE NEXT BEST THING: WE BUILD SONOMA'S SAFETY SYSTEMS AROUND THE PRINCIPLE OF PROTECTING YOU AND YOUR PASSENGERS

from accidents in the first place. ■ You start out with an advantage as soon as you sit down. You're seated high above the road, while your sweep of vision is improved 31 percent, compared with previous models. So you take in a view that can help keep you out of trouble developing ahead. ■ Of course, the nature of accidents is surprise, so your next line of preventive action is standard anti-lock brakes – rear wheel ABS with the 4-cylinder engine, four-wheel ABS with either V6. In Sonoma's available push-button 4x4, you have one more way to outmaneuver trouble on slick roads. ■ And in the event of an accident, your seat

SAFETY

belt is the most important safety equipment you can use. In addition, Sonoma has side-guard door beams, to partially absorb side impact and help prevent cab intrusion, frame and body crush zones that help absorb crash energy, an energy-absorbing steering column and instrument panel and a self-aligning steering wheel.

We're not prophets, either – but we thought you'd rest easier knowing these things.



REDIRECTING ENERGY

IN THE EVENT OF A CRASH, SIDE-GUARD DOOR BEAMS DEFLECT SIDE-IMPACT ENERGY TO HELP REDUCE OR PREVENT CAB INTRUSION.



ENERGY-ABSORBING

SONOMA'S STEERING COLUMN AND DASH ABSORB ENERGY TO HELP PROTECT YOUR BODY IN ACCIDENTS. BECAUSE SOMETIMES STRENGTH MEANS KNOWING WHEN TO GIVE.

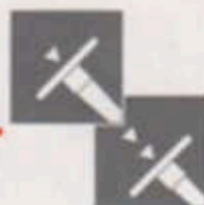

FOLDS UNDER PRESSURE

"CRUSH ZONES" CRUMPLE TO ABSORB AND DISSIPATE FRONT- AND REAR-IMPACT ENERGY OUTSIDE THE PASSENGER CAGE – TO HELP MAINTAIN PASSENGER SAFETY.

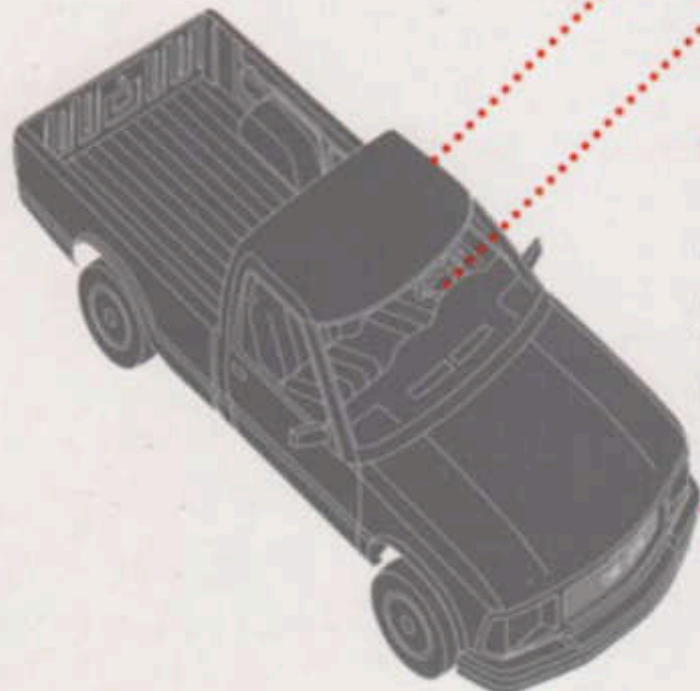

AN EVEN BRAKE

THE ANTI-LOCK SYSTEM SENSES REAR-WHEEL SLOWDOWN AND WORKS THE BRAKES, CONTROLLING THEM AS NEEDED. REAR-WHEEL ABS STANDARD WITH 4-CYLINDER ENGINES, 4-WHEEL ABS STANDARD WITH 6-CYLINDER ENGINES.





SONOMA'S ERGONOMICALLY ENGINEERED

INTERIOR OFFERS LOTS OF SPACE: LOTS OF HEAD, SHOULDER AND HIP ROOM. QUIETER SPACE, TOO. FLUSH-MOUNTED

glass cuts wind noise. The engine is quieter this year. Acoustical dampers and seals help silence the floor, doors and cowl. Tight fit and finish, and fewer parts overall, help eliminate squeaks and rattles. ■ The air conditioning and heater are 32 percent more efficient than last year. The seats are bolstered for long-distance comfort. (They're treated with Scotchgard®, too.) Cupholders are standard. ■ The instrument panel

ENVIRONMENT has full analog gages. It also has

two conveniently placed power outlets, available, ready for that notebook computer and cellular phone, or whatever other instruments you might need to power.



CONVENIENT STORAGE

THE CENTER ARMREST/CONSOLE, STANDARD WITH BUCKETS, AVAILABLE WITH THE SPLIT BENCH, HAS LOTS OF SPACE AND SOFT-LINED COMPARTMENTS.



SHIFT ON THE FLY

SONOMA 4X4 CAN SHIFT INTO 4WD ON THE FLY, AT ANY SPEED. IT'S CALLED INSTA-TRAC®. NO STOPPING. NO SPEED LIMITATION. AVAILABLE AT EVERY TRIM LEVEL. GREAT FOR OFF-ROADING. AND GREAT FOR SAFER TRACTION ON-ROAD.

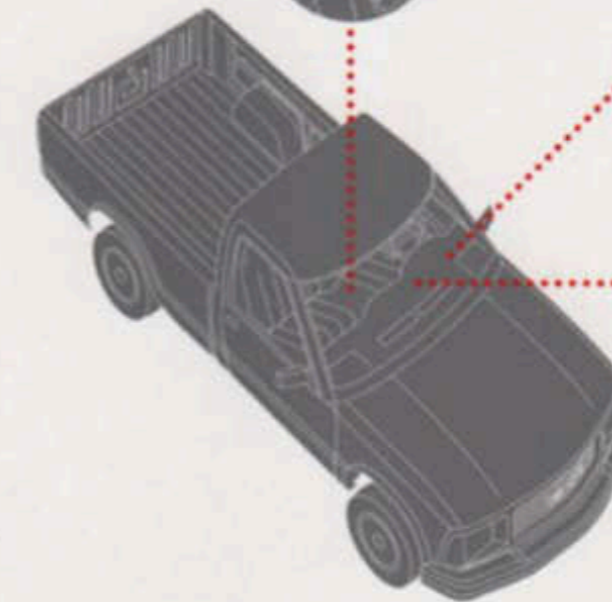

A SOFT TOUCH

TO COMPLEMENT THE QUIET RIDE, CHOOSE AN AVAILABLE SOUND SYSTEM - EVEN A CD CHOICE. SONOMA'S FINGER-FRIENDLY AIR CONDITIONING (AVAILABLE) CONTROLS ARE RIGHT AT HAND, TOO.

SIX GOOD TURNS

CLOCKWISE FROM LEFT: ■ 2WD STEEL WHEEL WITH CENTER CAP ■ 2WD STEEL WHEEL WITH BRIGHT TRIM RING AND LUG-TYPE CENTER CAP ■ 2WD ALUMINUM WHEEL WITH MATCHING METAL CENTER CAP ■ 4X4 STEEL WHEEL SHOWN WITH AVAILABLE BRIGHT TRIM RING ■ 4X4 ALUMINUM WHEEL ■ 2WD ALUMINUM WHEEL WITH LUG-TYPE CENTER CAP.

CLUB COUPE

SONOMA CLUB COUPE GIVES YOU A GREAT COMBINATION: THE CAPABILITIES OF A TRUCK WITH A SUPERB RIDE AND ADDITIONAL PASSENGER SPACE. MORE OF THE FREEDOM THAT ONLY A TRUCK CAN GIVE YOU.

BOX OPTIONS

LONG AND SHORT BOX, DEPENDING ON YOUR NEEDS OR AMBITIONS. BOTH HAVE SIDE RECESSES FOR TWO-TIER LOADING, AND THE TAILGATE IS REMOVABLE WITHOUT TOOLS.

A FIRM GRIP

AVAILABLE ON SLS AND SLE, THE LEATHER-WRAPPED STEERING WHEEL LENDS SONOMA ONE MORE TOUCH OF CLASS.

SOUND ADVICE

SONOMA'S QUIET RIDE IS MADE MORE PLEASANT YET BY THE STANDARD DELCO AM/FM STEREO. OR GO WITH THE AVAILABLE AM/FM CASSETTE OR AM/FM/CD SOUND SYSTEM.

LEADING EDGE

■ SL GRAY GRILLE ■ SLS BODY-COLORED GRILLE WITH COMPOSITE HEADLAMPS (HIGH RIDER SHOWN) ■ SLE STEEL GRAY-COLORED GRILLE WITH BRIGHT TRIM RING AND COMPOSITE HEADLAMPS.



A PICKUP THAT HAULS

THE AVAILABLE HEAVY-DUTY TRAILER HITCH AND EQUIPMENT GIVE SONOMA A LOT OF PULL.

DUAL HINDSIGHT

AVAILABLE ELECTRIC DUAL SWING-AWAY SIDE MIRRORS HELP KEEP YOU UP TO DATE ON WHAT'S GAINING ON YOU - OR WHAT'S FALLING BEHIND.

HOW TO BUILD YOUR SONOMA OPTIONS

EXTERIOR EQUIPMENT

	SLE	SLS	SL
<input type="checkbox"/> AIR DEFLECTOR AND FOG LAMPS: 2WD only	A	A	-
<input type="checkbox"/> BUMPERS, FRONT AND REAR: Gray with gray end caps	-	-	S
<input type="checkbox"/> Body-colored with matching end caps	-	S	-
<input type="checkbox"/> Steel gray metallic with matching rub strips, end caps and bright inserts	S	-	-
<input type="checkbox"/> GRILLES: Gray with standard headlamps	-	-	S
<input type="checkbox"/> Lower body-colored with composite headlamps	-	S	-
<input type="checkbox"/> Steel gray metallic, composite headlamps and bright trim	S	-	-
<input type="checkbox"/> MIRRORS, BLACK: With adjustable heads	-	-	S
<input type="checkbox"/> Below-eyeline type with pivoting arm and adjustable heads	S	S	A
<input type="checkbox"/> Dual electric below-eyeline type	A	A	-
<input type="checkbox"/> WHEELS: 2WD: Steel, painted gray with argent center cap	-	-	S
<input type="checkbox"/> Steel, painted gray with bright trim ring and argent lug-type center cap	S	S	-
<input type="checkbox"/> Aluminum with argent lug-type center cap	-	A	-
<input type="checkbox"/> Aluminum with matching brushed metal center cap	A	-	-
<input type="checkbox"/> 4x4: Steel, painted gray with matching center cap	-	-	S
<input type="checkbox"/> Steel, painted gray with matching center cap and bright trim ring	S	S	-
<input type="checkbox"/> Aluminum, argent, textured with integrated center cap	A	A	-

FUNCTIONAL EQUIPMENT

<input type="checkbox"/> COLD CLIMATE PACKAGE	A	A	A
<input type="checkbox"/> DIFFERENTIAL, LOCKING REAR: 4x4 only	A	A	A
<input type="checkbox"/> ELECTRONIC SHIFT TRANSFER CASE: 4x4 only	A	A	-
<input type="checkbox"/> SHIELD PACKAGE, UNDERBODY: 4x4 only	A	A	A

AVAILABLE OPTIONS: 1 SLIDING REAR WINDOW 2 EXTRA ELECTRICAL OUTLETS* 3 TILT STEERING WHEEL 4 INSTRUMENT PANEL WITH TACHOMETER 5 SPEED CONTROL 6 CUPHOLDERS (WITH BUCKET SEATS)

<input type="checkbox"/> SUSPENSION PACKAGES: Solid smooth ride ¹	A	A	A
<input type="checkbox"/> Heavy-duty ¹	A	A	A
<input type="checkbox"/> Sport, 2WD only ¹	A	A	A
<input type="checkbox"/> Off-road, 4x4 only ¹	A	A	A
<input type="checkbox"/> Highrider, 4x4 only ¹	-	A	-
<input type="checkbox"/> TRAILERING PACKAGE, HEAVY-DUTY: Includes platform hitch, wiring harness, heavy-duty flasher and cooling system	A	A	A

INTERIOR COMFORT AND CONVENIENCE FEATURES

<input type="checkbox"/> AIR CONDITIONING	A	A	A
<input type="checkbox"/> FLOOR COVERING: Full floor black vinyl	A	A	S
<input type="checkbox"/> Full floor color-keyed carpeting	S	S	A
<input type="checkbox"/> POWER LOCKS, WINDOWS AND DUAL ELECTRIC MIRRORS	A	A	-
<input type="checkbox"/> RADIOS: AM/FM stereo ²	S	S	S
<input type="checkbox"/> AM/FM stereo with cassette ²	A	A	A
<input type="checkbox"/> AM stereo/FM stereo with cassette and graphic equalizer ^{2,3}	A	A	A
<input type="checkbox"/> AM/FM stereo with CD player and 4 coaxial speakers ²	A	A	A
<input type="checkbox"/> SEATING: Front 3-passenger bench in custom vinyl or cloth	-	-	S
<input type="checkbox"/> High-back reclining bucket seats in deluxe cloth with center console	A	S	-
<input type="checkbox"/> 60/40 reclining split bench in deluxe cloth with folding center armrest	S	A	-
<input type="checkbox"/> TACHOMETER ⁴	A	A	A

A=Available S=Standard --=Not available

¹Not available on SL models.

²Some suspension packages are limited to certain models. See your dealer for details.

³Also includes seek-scan, digital clock, premium 4-speaker system with mast antenna.

⁴Receives C-Quam[®] AM stereo broadcasts. Check your local stations for compatibility.

⁵Standard with 4.3L V6 CFI.

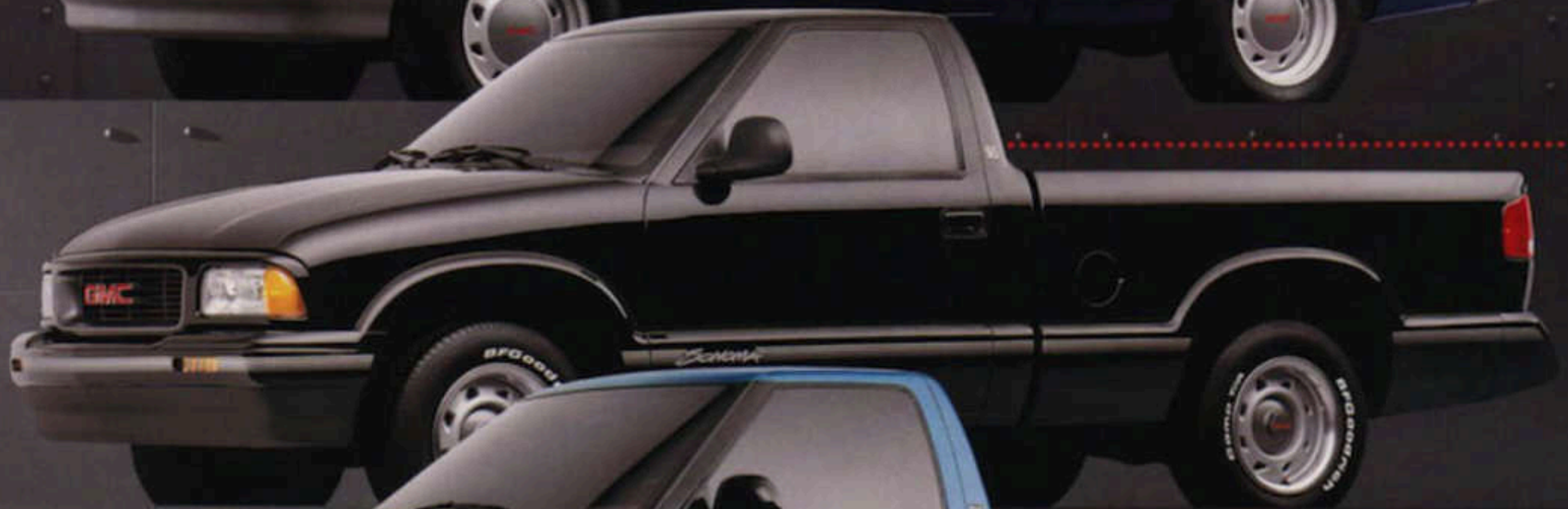

HOW TO BUILD YOUR SONOMA TRIM LEVELS



SONOMA SL

2WD IN RADAR PURPLE METALLIC
ABOVE, FULL BENCH SEAT IN MEDIUM SMOKE GRAY CUSTOM CLOTH



SONOMA SLS

2WD IN MIDNIGHT BLACK
ABOVE, RECLINING HIGH-BACK BUCKET SEATS
IN GRAPHITE DELUXE CLOTH



EXTERIOR COLORS

- RASPBERRY METALLIC
- FROST WHITE
- ULTRASILVER METALLIC
- STEEL GRAY METALLIC*
- MIDNIGHT BLACK
- RADAR PURPLE METALLIC
- BRILLIANT BLUE METALLIC
- CHERRY RED METALLIC
- BRIGHT TEAL METALLIC
- KHAKI
- APPLE RED



PAINT APPLICATIONS

FROM LEFT, SOLID PAINT AVAILABLE ON SL OR SLS; SPECIAL TWO-TONE PAINT
AVAILABLE ON SLS; CONVENTIONAL TWO-TONE PAINT STANDARD ON SLE



SONOMA HIGHRIDER

4X4 IN BRILLIANT BLUE METALLIC
ABOVE, RECLINING HIGH-BACK BUCKET SEATS IN BLUE DELUXE CLOTH



SONOMA SLE

4X4 IN CHERRY RED METALLIC UPPER, STEEL GRAY METALLIC LOWER
ABOVE, 60/40 RECLINING SPLIT BENCH IN BEIGE DELUXE CLOTH

INTERIOR/EXTERIOR COLOR COMBINATIONS

	AVAILABLE INTERIOR TRIM COLORS			
	BEIGE	BLUE	GRAPHITE	GRAY
<input type="checkbox"/> MIDNIGHT BLACK (19)	■			
<input type="checkbox"/> BRILLIANT BLUE METALLIC (22)		■		
<input type="checkbox"/> KHAKI (52)	■			
<input type="checkbox"/> RADAR PURPLE METALLIC (21)			■	
<input type="checkbox"/> RASPBERRY METALLIC (85)			■	
<input type="checkbox"/> CHERRY RED METALLIC (94)	■		■	
<input type="checkbox"/> APPLE RED (72)			■	
<input type="checkbox"/> ULTRASILVER METALLIC (96)		■	■	
<input type="checkbox"/> BRIGHT TEAL METALLIC (38)	■		■	
<input type="checkbox"/> FROST WHITE (12)	■	■	■	■

Exterior/interior color availability subject to trim level restrictions. See your dealer for details.
*Secondary color on two-tones only.

HOW TO BUILD YOUR SONOMA SPECIFICATIONS

AT A GLANCE

ENGINE	Gasoline		
CAPACITY/CONFIGURATION/CYLINDERS	2.2L I-4 (2WD only)	4.3L V6	4.3L V6
ORDERING CODE	LN2	LB4	L35
CUBIC-INCH DISPLACEMENT	133	262	262
BORE AND STROKE (IN)	3.5 x 3.46	4.0 x 3.48	4.0 x 3.48
COMPRESSION RATIO	9.0:1	9.1:1/8.3:1 ¹	9.1:1
FUEL DELIVERY	Multi-port injection	Throttle-bore injection	Central-port injection
SAE NET HORSEPOWER @ RPM	118 @ 5200	165 @ 4000	195 @ 4500
SAE NET TORQUE @ RPM	130 @ 2800	235 @ 2400	260 @ 3600
TRANSMISSIONS	5-speed manual with overdrive and 4-speed automatic with overdrive are available dependent upon engine and body style combinations and subject to emissions requirements		

TRAILERING DATA AND REAR AXLE RATIOS FOR ENGINES WITH AUTOMATIC TRANSMISSIONS

GROSS COMBINATION WEIGHT RATING (LBS.)	6000	6500	7500	8000	8500	9000	9500	10,000	10,500
2.2L I-4	3.73	4.10	—	—	—	—	—	—	—
4.3L V6	—	—	—	—	3.08	—	3.42 ²	3.73 ²	4.10
4.3L ENHANCED V6	—	—	—	—	3.08	—	3.42	3.73	4.10

TECHNICAL DATA

MODEL TYPE	2WD	4x4
GVW RATING (LBS.)	4200	4600
FRONT SUSPENSION	Independent coil springs	Independent torsion bars
AXLE CAPACITY (TOTAL LBS.)	2500 (all)	2700 (all)
SPRING CAPACITY (TOTAL LBS.)	2500 (all)	2700 (all)
TORSION-BAR CAPACITY (TOTAL LBS.)	—	1350 (all)
REAR SUSPENSION	Semi-elliptic 2-stage multileaf springs	
AXLE CAPACITY (TOTAL LBS.)	2700 (all)	2900 (all)
SPRING CAPACITY (TOTAL LBS.)	1150	1350
BRAKES	Front disc/rear drum with anti-lock rear brakes; 4-wheel anti-lock brakes with 4.3L engine	
STEERING	Variable ratio with integral power	
FUEL TANK CAPACITY	20 gallons	
FREEDOM BATTERY	12-volt, maintenance-free	
CCA RATING	Standard: 525; available: 690	
ALTERNATOR AMPS	100	

MARKETING OPTION PACKAGES

MARKETING OPTION PACKAGE 1 (SL ONLY)	Wideside pickup equipment SL decor
MARKETING OPTION PACKAGE 2 (SL ONLY)	Wideside pickup equipment SL decor Radio delete Bumper delete
MARKETING OPTION PACKAGE 3 (SLS AND SLE ONLY) ³	Wideside pickup equipment SLS Sport decor ⁴
MARKETING OPTION PACKAGE 4 (SLS AND SLE ONLY) ³	Wideside pickup equipment SLS Sport decor ⁴ AM/FM with seek-scan, cassette, clock ⁵

SUSPENSION PACKAGE INFORMATION

SUSPENSION TYPE	2WD SOLID, SMOOTH	2WD HEAVY-DUTY	2WD SPORT	4X4 SOLID, SMOOTH	4X4 HEAVY-DUTY	4X4 OFF-ROAD	4X4 HIGH RIDER
USAGE	Ride	Work vehicle	Handling	Ride	Work vehicle	Recreation	Recreation
PRIMARY ROAD USE	Paved	Gravel/unimproved	Paved	Paved/gravel	Gravel/unimproved	Off-road	Off-road
CARGO CAPACITY	Good	Maximum	Good	Good	Maximum	Good	Good
TRAILERING	Light-duty	Heavy-duty	Heavy-duty	Light-duty	Heavy-duty	Heavy-duty	Heavy-duty
RIDE	Smooth	Very firm	Smooth	Solid	Rugged/hard	Ride control	Ride control

CCA = Cold cranking amps

¹GVW above 8500.

²GCWR is reduced by 500 lbs. when truck is equipped with P235/75R15 tires.

³Aluminum wheels also available at no additional cost when properly equipped. See your dealer for details.

⁴May be upgraded to SLE decor. SLS not available with TS10803 or TT10803. See your dealer for details.

⁵May be upgraded to AM/FM/cassette with graphic equalizer or AM/FM/CD at additional cost. See your dealer for details.



WITH YOUR PURCHASE OR LEASE OF A SONOMA, YOU'LL GET A WALLET-SIZED PLASTIC CARD. IT'S THE COMMITMENT PLUS CARD, STANDARD WITH EVERY GMC TRUCK. AND IT STANDS FOR A POWERFUL PACKAGE OF BENEFITS THAT YOU'LL APPRECIATE

throughout the years you own your GMC Truck. When you acquire your truck, Commitment Plus means you get a full tank of fuel on delivery of your vehicle. We'll also see you through the first few miles with a complimentary 3000-mile inspection, lube and oil change, and ongoing contacts by your Commitment Plus representatives. Later, when you bring in your Sonoma for warranty service, your dealer will offer you Courtesy Transportation: for same-day service, a one-way shuttle to your destination up to 10 miles from the dealership; if your truck is in overnight, a free loaner vehicle or up to \$30 a day reimbursement for a rental vehicle.

COMMITMENT PLUS

And finally, Commitment Plus stays on the road with you, bringing you 24-hour Roadside Assistance in emergencies. **1-800-GMC-TRUCK** With GMC Truck Roadside Assistance, you're never more than a toll-free phone call away from a GMC Truck product specialist. And never more than a phone call away from on-the-road



service. Should you ever need help on the road, we can provide access to towing, locksmith, auto glass, tire repair, gasoline delivery, police, fire and hospital, even hotel reservations and alternative transportation. (Most services paid by owner.) And Roadside Assistance representatives can even put you in touch with the nearest local GMC Truck dealer. This is the kind of security that money can't buy – because we give it to you with your GMC Sonoma. (Some models not eligible; restrictions apply. See your dealer for complete details, terms and conditions. Available only in the continental United States and Hawaii.) **WARRANTY PROTECTION** As strong as Sonoma is, equally strong is the warranty coverage with which GMC Truck backs it. It's our Bumper to Bumper warranty. The entire vehicle is warranted for repairs, including parts and labor, to correct defects in materials or workmanship, for 3 years or 36,000 miles (excludes routine maintenance; tires are warranted by their manufacturers). The warranty covers towing to the nearest GMC Truck dealership, and there is no deductible for warranty repairs during the warranty period. The warranty transfers automatically with vehicle ownership, too, during the warranty period. Body sheet metal rust-through is covered for 6 years or 100,000 miles. (You should, of course, see your dealer for terms and conditions of this limited warranty.)



THE STRENGTH OF EXPERIENCE