

# INTERNATIONAL®



# 908 C

Vehicle illustrated may include Optional Equipment and does not necessarily include all standard equipment.

## RATINGS

MAXIMUM GROSS VEHICLE WEIGHT.....4,000 lbs.

## STANDARD EQUIPMENT

### AXLE, FRONT

FA-1 2,500-lb capacity  
Heat-treated forged-steel I beam

### AXLE, REAR

RA-18 3,500-lb capacity  
Hypoid single reduction, 8½" ring gear  
Semi-floating induction-hardened flanged shafts

Ratios: 3.31, 3.54 or 3.73

### BODY

6 ft. 8 in. regular or Bonus-Load pick-up  
with inner body tire carrier

### BRAKE, PARKING

Mechanical control of rear service brakes  
Foot pedal applied, finger lever released  
Total lining area: 81.9 sq. inches

### BRAKES, SERVICE

Self-adjusting hydraulic, dual operation  
with warning light  
Single-cylinder, single-piston front,  
single-cylinder, double-piston rear  
Size: 12 × 2" front, 11 × 1¾" rear  
Total area: 179.7 sq. inches

### CAB

All steel with safety glass windows  
and sweep-around windshield  
Door locks both sides with safety latches  
Non-glare padded instrument panel with  
ammeter, fuel, water temperature and oil  
pressure gauges  
Full-width adjustable seat with Torflex  
spring construction, vinyl upholstery  
and polyurethane foam cushion  
Acoustical roof headliner

### AXLE, REAR

RA-28 3,500-lb capacity single reduction  
with Powr-Lok limited slip differential  
Ratios: 3.31, 3.54 or 3.73

### BRAKES

Vacuum power assist

### CAB

Passenger side padded sun visor  
Left or right side arm rest  
Right side chrome mirror  
Truck type outside mirrors  
Glove compartment lock; tinted glass  
Deluxe trim package

### CAB (Continued)

Rubber floor mat with sound deadening  
insulation; seat belts and shoulder  
harness anchors  
Fresh air heater and defroster  
Padded sun visor for driver  
Ash tray; hand choke  
Two-speed non-glare electric windshield  
wipers and electric washers  
Chrome door mounted and inside rear  
view mirrors

### CLUTCH

10-inch 9-spring, single-plate  
Hydraulic control; vibration dampener

### COOLING SYSTEM

20-quart system capacity  
Radiator frontal area: 497 sq. inches  
Permanent type anti-freeze—20°F

### ELECTRICAL SYSTEM

12-volt 32-amp alternator  
50 amp-hr, 54 plate battery  
Fuse panel in glove compartment  
Dual stop and tail lights  
Dome light; single electric horn  
Directional signals: front in parking  
lights, rear in stop lights  
Traffic hazard switch  
Back-up lights  
Front side marker lamps

### ENGINE

International V-266 gasoline, V-8  
Gross BHP: 154.8 @ 4400 rpm  
Gross torque: 227.1 lb/ft @ 2800 rpm  
266 cu. in. displmt; 8.4 comp ratio

## OPTIONAL EQUIPMENT

### CAB (Continued)

Exterior trim package  
Air conditioner  
Front bucket seats with console

### CLUTCH

11-inch 9-spring

### COOLING SYSTEM

Increased capacity cooling

### ELECTRICAL SYSTEM

12-volt 61-amp alternator  
60 or 70 amp-hr battery  
Cigar lighter;  
Dual electric horns; radio

### ENGINE (Continued)

Dry-type air cleaner; full-flow oil filter  
Exhaust emission control

### FINISH

Chassis—black; bumper—white  
Cab, body and wheels: choice of  
any standard IH color

### FRAME

Pressed steel channel main rails  
6<sup>1</sup>/<sub>16</sub> × 2<sup>3</sup>/<sub>32</sub> × 0.135"  
3.68 section modulus  
Formed-channel front bumper

### FUEL TANK

19-gallon, mounted under cab

### STEERING

S-8 gear, with 17-inch steering wheel  
and collapsible column

### SUSPENSION

Semi-elliptic steel leaf springs  
Front: 2½ × 46"; 2,310-lb capacity  
Rear: 2½ × 52"; 2,210-lb capacity  
Front and rear shock absorbers

### TRANSMISSION

T-13 3-speed synchromesh, direct  
Floor mounted gear shift lever  
Ratios: 2.80, 1.85, 1.00; 4.53 rev.

### WHEELS AND TIRES

Single front and rear, with spare  
7.75 × 15, 4-PR tubeless tires  
5-stud disc wheels, with 5.50 K rims  
5½" bolt circles  
Painted hub caps, front and rear

### ENGINE

Hand throttle control; automatic choke

### FRAME

Chrome front or rear bumper  
White rear bumper

### SUSPENSION

Progressive rear springs

### TRANSMISSION

T-44 4-speed synchromesh, direct

### WHEELS AND TIRES

8.15 × 15., 4-PR tubeless tires  
Deluxe chrome hub caps, front and rear

## DIMENSIONS AND WEIGHTS WITH STANDARD COMPONENTS

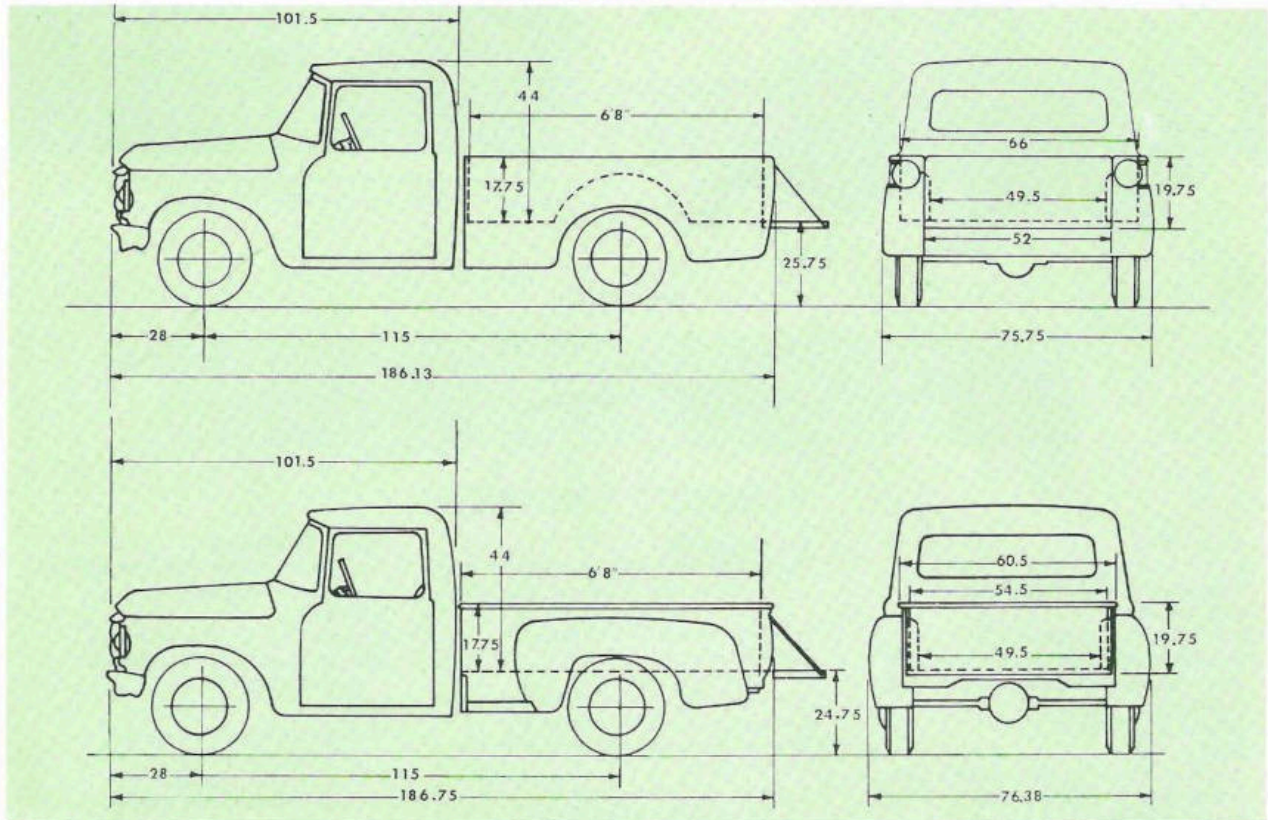

### DIMENSIONS, with 7.75 x 15 TIRES

Overall Width: 78" at front fenders	Ground Clearance: 7.0" at front axle 7.1" at rear axle	Frame Height at Rear Axle: 24.5" empty 21.3" loaded
Overall Height: 68.6" at top of cab		

### CHASSIS DIMENSIONS and WEIGHTS

WB	CHASSIS WEIGHTS, LBS. <sup>o</sup>			DIMENSIONS				TURNING RADIUS	
	Front	Rear	Total	CA	CF	AF	OAL	To Centerline of Tire	With Bumper Clearance
115"	2,105	1,350	3,455	42.0"	81.3"	39.3"	182.8"	19 ft. 4 in.	20 ft. 9 in.

*<sup>o</sup>With cab, standard equipment and tires, oil, fuel and water.*

### TIRE DIMENSIONS

TUBELESS TIRES ON DISC WHEELS		
Tire Size	7.75 x 15	8.15 x 15
Rim Size	5.50K	5.50K
Outside Width OW	69.0"	69.5"
Tread Width TW	61.4"	61.4"
Inside Width IW	53.9"	53.4"
Chain Clearance	5.1"	4.8"
Front Tread	61.4"	61.4"

*In order that product improvements may be introduced at any time specifications are subject to change without notice.*



INTERNATIONAL HARVESTER COMPANY • 401 NORTH MICHIGAN AVE. • CHICAGO, ILLINOIS 60611

CT-400-F. AD-4300-U7. 1-1-

ORDER AD SPEC. SHEETS ON AD-4130.

Litho in United States of America