

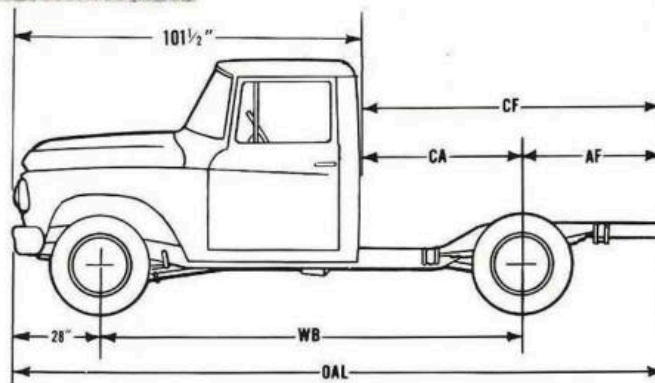

# INTERNATIONAL<sup>®</sup> C-120 (4x4) SERIES

MAXIMUM GVW, 7,000 LB.



## CHASSIS DIMENSIONS

Wheelbase (WB).....	115	119	122	131	134	140 *
Overall length w/ bumper (OAL)	186.8	186.8	186.8	204.8	204.8	208.3
Back of cab to c/l, rear axle (CA)	42.0	45.5	49.0	57.5	61.0	33.5
C/l rear axle, end of frame (AF)	43.3	39.8	36.3	45.8	42.3	39.8
Back of cab to end of frame (CF)	85.3	85.3	85.3	103.3	103.3	71.5
Turning radius (in feet) .....	24 1/4	25 1/4	25 3/4	27 1/4	27 3/4	29
Weight with cab, fuel, oil, water, standard equip., approx. (lb.)	3811	3815	3821	3939	3944	4387

\*Travelette only.

Dimensions are given in inches. The following are the same for all wheelbases, based on use of 7-17.5 tires:

Tread: Front wheels, 63.5; rear, 63.

Road Clearance: Front, 9.2; rear, 8.3.

Overall Width: Front, 78; rear, 70.3.

Maximum Height to top of frame from ground, at rear axle, loaded; 27.7.

## STANDARD SPECIFICATIONS

**Axle, Front:** Rated capacity, 2,800 lb. Single reduction, hypoid type. Fore and aft steering hook-up. Tapered roller differential bearings. Overhung pinion. Reduction, 4.1 or 4.77 to 1.

**Axle, Rear:** Rated capacity, 4,500 lb. Full-floating, single reduction, hypoid type. Hotchkiss type final drive. Induction-hardened axle shafts. Differential and wheel bearings are tapered rollers. Pinion is straddle-mounted, supported on roller bearings. Reduction, 4.1 or 4.77 to 1.

**Brake, Hand:** Pedal applied, finger released, rear wheel internal-expanding type; effective lining area, 92.2 in.

**Brakes, Service:** Hydraulic, one-way Servo front, duo Servo rear. Effective lining area, 172.9 sq. in.

**Cab:** All-steel with Sweep-Around windshield, side, rear and stainless steel-edged adjustable-tension Silent-Vent wing windows, all of safety glass. Adjustable full-width seat with nylon covered foam rubber seat cushion and cotton padded back cushion. Instrument panel with direct-reading gauges; chrome-plated control knobs. Safety type door latches; door locks both sides. Full-width floor with insulated mat. Vinyl-coated insulated headliner. Metal door trim panels. Dual two-speed electric windshield wipers. Inside overhead rear-view

mirror. Left side sun visor. Ash tray. Map compartment.

**Clutch:** Hydraulic, 11-in. diameter, 9-spring, single plate, cushion dry disc, with coil spring vibration damper. Facing area, 123.7 sq. in.

**Cooling System:** Centrifugal pump, balanced circulation with permanent by-pass for fast, even warm-up. V-belt drive. Fin-and-tube radiator. Large capsule type thermostat. Total capacity, 15 qt.

**Electrical System:** 12-volt. Pressure-centrifugal control type distributor. 50-amp.-hr. capacity battery. Ignition key solenoid-actuated, positive engagement drive starting motor. 30-amp. generator. Dual sealed-beam headlights. Nine-circuit fuse panel on firewall for wiring without circuit breakers.

**Engine:** INTERNATIONAL V-266, Y-block, short-stroke, low-friction, low-stress, eight-cylinder, gasoline, valve-in-head. Bore, 3 3/8 in.; stroke, 3 1/2 in.; displacement, 266 cu. in.; compression ratio, 8.4 to 1. Maximum brake horsepower, 154.8 at 4400 r.p.m.; maximum torque, 227.1 lb.-ft. at 2800 r.p.m. Five steel-backed, replaceable-shell, precision type main bearings. Five camshaft bearings. Nine rocker arm shaft supports. Slo-rotor exhaust valves faced with heat-resistant alloy. Exhaust valve seat inserts. Hydraulic tappets. Water-jacketed



INTERNATIONAL TRUCKS—World's Most Complete Line!

intake manifold. Balanced assembly of crankshaft, flywheel and front pulley.

**Equipment, Standard:** Front bumper. Combination tail and stop light. Parking lights. Horn. Spare wheel.

**Finish:** Frame and wheels, black. Hood, cab and fenders painted in your choice of attractive solid standard colors. Anodized aluminum grille.

**Frame:** Pressed steel channel, 7 x 3 x 3/8 in.

**Fuel System:** Horizontal diaphragm, mechanical fuel pump driven from camshaft. Fuel filter. Downdraft carburetor. Large capacity, high efficiency, oil bath air cleaner. Fuel tank, 19-gal., right side, under cab.

**Lubrication System:** Full pressure feed to all main, connecting rod and camshaft bearings. Deep sump oil pan. External gear type oil pump; wire mesh floating oil strainer. Full-flow oil filter. Oil capacity (refill), 6 qt.

**Propeller Shaft:** Large-diameter, heavy-gauge steel tubing, dynamically balanced. Needle bearing, anti-friction universal joints.

### OPTIONAL EQUIPMENT AT ADJUSTED COST

**Air Conditioner:** Efficient, quiet, low-humidity unit with dual adjustable-position nozzles.

**Axle, Rear:** Special with Powr-Lok differential, assures power flow to non-spinning wheel in mud, sand or on ice.

**Bodies:** TRAVELALL® station wagon, 4 side doors, for 3 to 9 passengers. Standard body with single full-width seat, panel type rear doors. Custom body with second full-width intermediate fold-down seat, tail gate with electrically-controlled roll-down window, deluxe trim features. Third full-width rear seat available for both bodies. Intermediate seat and tail gate also optional for Standard body . . . Pickup body, 7 or 8 1/2-ft. inside length, Standard or flush-side Bonus-Load . . . Stake or platform, 8 or 9-ft. . . . Service-Utility, 79, 89 or 100-in., with or without fully-enclosed cargo area.

**Brakes:** Hydrovac power brake system.

**Cab:** TRAVELETTE®. Four-door, six-passenger, with two full-width seats, increased rear-seat area. Available with 6-ft. Bonus-Load pickup body or 82.5-in. Service-Utility body.

**Cab or Body Equipment:** Tinted glass. Special rear-view mirrors. Arm rests. Right side sun visor. Cigar lighter. Dome light. Glove compartment lock. Special paint color.

**Chassis Equipment:** Chrome front bumper. Black rear bumper. Chrome hub caps.

**Clutch:** 10-in. diameter (for BD engine). 12-in. diameter, 12-spring (for V-8 engine).

**Electrical System:** 60 or 70-amp.-hr. battery, 50-amp. heavy-duty generator. 35 or 50-amp. charge-at-idle generator. 60-amp. AC-DC alternator. Dual stop and tail lights. Dual electric horns. Front corner and marker lights. Directional signals, Class A, front and rear; hazard switch.

**Springs:** Semi-elliptic. Front, 42 x 2 1/2 in. Rear, 52 x 2 1/2 in. Shock absorbers, direct acting, front and rear.

**Steering:** Semi-reversible, dual ratio, cam and roller-mounted twin lever gear. Four-spoke, 17-in. diameter, safety type steering wheel.

**Tires:** Front and single rear, tubeless, 7-17.5 TT, 6-ply. Tire carrier.

**Transfer Case:** Declutching type. Single control lever, four-position shifting—low range four-wheel drive, 1.96 to 1 reduction; neutral; high range four-wheel drive, direct; high range two-wheel drive, front wheels disengaged. Provision for mounting full torque power take-off at rear of input shaft.

**Transmission:** Synchromesh type, three speeds forward, one reverse. Remote control shift lever on steering post. Reductions—low, 3.039 to 1; second, 1.641 to 1; third, direct; reverse, 3.682 to 1.

**Wheels:** Disc type, 5.25 rims.

**Engine:** INTERNATIONAL BD-240, I-block, high-torque, six-cylinder, gasoline, valve-in-head. Bore, 3 3/8 in.; stroke, 4.018 in.; displacement, 240 cu. in. Maximum brake horsepower, 140.8 at 3800 r.p.m.; maximum torque, 223.5 lb.-ft. at 2000 r.p.m.

**Engine:** INTERNATIONAL V-304, Y-block, short-stroke, low-friction, low-stress, eight-cylinder, gasoline, valve-in-head. Bore, 3 7/8 in.; stroke, 3 7/8 in.; displacement, 304 cu. in. Maximum brake horsepower, 193.1 at 4400 r.p.m.; maximum torque, 272.5 lb.-ft. at 2800 r.p.m.

**Engine Equipment:** High altitude equipment . . . Increased capacity cooling . . . Governor for BD-240 . . . Hand throttle control . . . Positive crankcase ventilator . . . Heavy-duty air cleaner . . . LPG fuel system equipment, without fuel tanks, for BD-240.

**Heater and Defroster:** Recirculating and fresh air type . . . Super capacity unit.

**Power Take-Off:** Transmission or full-torque transfer case type.

**Power Steering:** Cylinder, valve, reservoir and pump.

**Radio:** Semi-transistor, center-mounted on instrument panel, with outside aerial.

**Snow Plow:** 7 or 8-ft. blade.

**Springs:** Rear, leaf type auxiliaries.

**Tires:** Tubeless or tubed, alternate sizes. Special treads. Underslung tubular or bar type tire carrier. Tire lock.

**Transmission:** Four-speed synchromesh with left side power take-off opening. Reductions—low, 6.398 to 1; second, 3.092 to 1; third, 1.686 to 1; high, direct; reverse, 7.82 to 1.

**Winch:** Ramsey 200; 150-ft. 3/8-in. cable with hook.

*Specifications subject to change without notice.*

INTERNATIONAL HARVESTER COMPANY  
180 NORTH MICHIGAN AVE. • CHICAGO 1, ILLINOIS

