

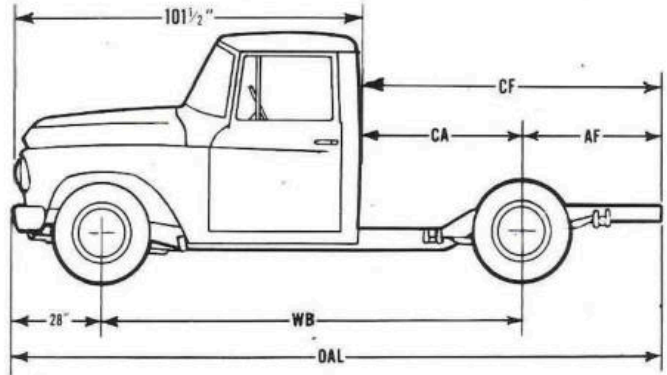

INTERNATIONAL® C-130 SERIES

MAXIMUM GVW, 8,800 LB.

MODEL	GVW RATING
C-130	7,000 lb.
C-132	8,800 lb.



CHASSIS DIMENSIONS

	122	131	134	140 *
Wheelbase (WB)	122	131	134	140 *
Overall length with front bumper (OAL)	186.8	204.8	204.8	208.3
Back of cab to c/l of rear axle (CA)	49.0	57.5	60.5	33.5
C/l of rear axle to end of frame (AF)	36.3	45.8	42.8	39.8
Back of cab to end of frame (CF)	85.3	103.3	103.3	71.5
Turning radius (in feet)	22	23 1/4	23 3/4	24 3/4
Weight with cab, fuel, oil, water, standard Model C-130, approx. (lbs.)	3630	3655	3666	4114 *

*Travelette only.

Dimensions are given in inches. The following are the same for all wheelbases, based on use of 8—17.5 tires:
Tread: Front wheels, 61.2; rear, 57.9.
Road Clearance: Front, 7.4; rear, 7.3.
Overall Width: Front, 78; rear, 67.6.
Maximum Height to top of frame from ground, at rear axle, loaded: 25.5.

STANDARD SPECIFICATIONS

Axle, Front: Rated capacity, 3,100 lb. Drop-center, I-beam, heat-treated, steel drop forging. Steering knuckles of drop-forged, heat-treated, chrome-molybdenum steel.

Axle, Rear: Rated capacity, 6,000 lb. Full-floating, single reduction, hypoid type. Hotchkiss type final drive. Induction-hardened axle shafts. Differential and wheel bearings are tapered rollers. Pinion is straddle-mounted, supported on roller bearings. Reduction, 4.3, 4.88, 5.57 or 6.16 to 1.

Brake, Hand: Pedal applied, finger released, rear wheel internal-expanding type; effective lining area, 123.2 sq. in.

Brakes, Service: Hydraulic, one-way Servo front, duo Servo rear. Effective lining area, 203.9 sq. in.

Cab: All-steel with Sweep-Around windshield, side, rear and stainless steel-edged adjustable-tension Silent-Vent wing windows, all of safety glass. Adjustable full-width seat with nylon covered foam rubber seat cushion and cotton padded back cushion. Instrument panel with direct-reading gauges; chrome-plated control knobs. Safety type door latches; door locks both sides. Full-width floor with insulated mat. Vinyl-coated insu-

lated headliner. Metal door trim panels. Dual two-speed electric windshield wipers. Inside overhead rear-view mirror. Left side sun visor. Ash tray. Map compartment.

Clutch: Hydraulic, 11-in. diameter, 9-spring, single plate, cushion dry disc, with coil spring vibration damper. Facing area, 123.7 sq. in.

Cooling System: Centrifugal pump, balanced circulation with permanent by-pass for fast, even warm-up. V-belt drive. Fin-and-tube radiator. Large capsule type thermostat. Total capacity, 15 qt.

Electrical System: 12-volt. Pressure-centrifugal control type distributor. 50-amp.-hr. capacity battery. Ignition key solenoid-actuated, positive engagement drive starting motor. 30-amp. generator. Dual sealed-beam headlights. Nine-circuit fuse panel on firewall for wiring without circuit breakers.

Engine: INTERNATIONAL V-266, Y-block, short-stroke, low-friction, low-stress, eight-cylinder, gasoline, valve-in-head. Bore, 3 5/8 in.; stroke, 3 7/8 in.; displacement, 266 cu. in.; compression ratio, 8.4 to 1. Maximum brake horsepower, 154.8 at 4400 r.p.m.; maximum torque, 227.1 lb.-ft. at 2800 r.p.m. Five steel-backed, replaceable-shell, precision type main bearings. Five camshaft



INTERNATIONAL TRUCKS — World's Most Complete Line!

bearings. Nine rocker arm shaft supports. Slo-rotor exhaust valves faced with heat-resistant alloy. Exhaust valve seat inserts. Hydraulic tappets. Water-jacketed intake manifold. Balanced assembly of crankshaft, flywheel and front pulley.

Equipment, Standard: Front bumper. Combination tail and stop light. Parking lights. Horn. Spare wheel. Bumper jack.

Finish: Frame and wheels, black. Hood, cab and fenders painted in your choice of attractive solid standard colors. Anodized aluminum grille.

Frame: Pressed steel channel, 7 x 3 x $\frac{3}{16}$ in.

Fuel System: Horizontal diaphragm, mechanical fuel pump driven from camshaft. Fuel filter. Downdraft carburetor. Large capacity, high efficiency, oil bath air cleaner. Fuel tank, 19-gal., right side, under cab.

Lubrication System: Full pressure feed to all main, connecting rod and camshaft bearings. Deep sump oil pan. External gear type oil pump; wire mesh floating

oil strainer. Full-flow oil filter. Oil capacity (refill), 6 qt.

Propeller Shaft: Large-diameter, heavy-gauge steel tubing, dynamically balanced. Needle bearing, anti-friction universal joints.

Springs: Semi-elliptic. Front, 46 x 2½ in. Rear, 52 x 2½ in. Shock absorbers, direct acting, front.

Steering: Semi-reversible, dual ratio, cam and roller-mounted twin lever gear. Four-spoke, 17-in. diameter, safety type steering wheel.

Tires: Front and single rear, tubeless, 8-17.5 TT, 6-ply. Tire carrier.

Transmission: Heavy-duty synchromesh type, three speeds forward, one reverse, conventional floor shift lever, improved shift mechanism. Reductions — low, 3.714 to 1; second, 1.871 to 1; high, direct; reverse, 4.588 to 1.

Wheels: Disc type, with 5.25 rims.

OPTIONAL EQUIPMENT AT ADJUSTED COST

Air Conditioner: Efficient, quiet, low-humidity unit with dual adjustable-position nozzles.

Brakes: Hydrovac power brake system.

Bodies: Pickup body, 8½-ft. inside length, Standard or flush-side Bonus-Load . . . Stake or platform, 8 or 9-ft. . . . Service-Utility, 89 or 100-in., with or without fully-enclosed cargo area . . . Dual rear fenders for Standard 8½-ft. pickup.

Cab: TRAVELETTE®. Four-door, six-passenger, with two full-width seats, increased rear-seat area. Available with 6-ft. Bonus-Load pickup body or 82.5-in. Service-Utility body.

Cab or Body Equipment: Tinted glass. Special rear-view mirrors. Arm rests. Right side sun visor. Cigar lighter. Dome light. Glove compartment lock.

Chassis Equipment: Chrome front bumper. Black rear bumper. Chrome front hub caps.

Clutch: 10-in. diameter (for BD engine). 12-in. diameter, 12-spring (for V-8 engine).

Electrical System: 60 or 70-amp.-hr. battery. 50-amp. heavy-duty generator. 35 or 50-amp. charge-at-idle generator. 60-amp. AC-DC alternator. Dual stop and tail lights. Dual electric horns. Front corner and marker lights. Directional signals, Class A, front and rear; hazard switch.

Engine: INTERNATIONAL BD-240, I-block, high-torque, six-cylinder, gasoline, valve-in-head. Bore, 3¾ in.; stroke, 4.018 in.; displacement, 240 cu. in. Maximum brake horsepower, 140.8 at 3800 r.p.m.; maximum torque, 223.5 lb.-ft. at 2000 r.p.m.

Engine: INTERNATIONAL V-304, Y-block, short-stroke, low-friction, low-stress, eight-cylinder, gasoline, valve-in-head. Bore, 3¾ in.; stroke, 3½ in.; displacement, 304 cu. in. Maximum brake horsepower, 193.1 at 4400 r.p.m.; maximum torque, 272.5 lb.-ft. at 2800 r.p.m.

Engine Equipment: High altitude equipment . . . Increased capacity cooling . . . Governor for BD-240 . . . Hand throttle control . . . Positive crankcase ventilator . . . Heavy-duty air cleaner . . . LPG fuel system equipment, without fuel tanks, for BD-240.

Heater and Defroster: Recirculating and fresh air type . . . Super capacity unit.

Power Steering: Cylinder, valve, reservoir and pump.

Radio: Semi-transistor, center-mounted on instrument panel, with outside aerial.

Snow Plow: 7 or 8-ft. blade.

Springs: Front, heavy-duty. Rear, heavy-duty; leaf type auxiliaries; shock absorbers.

Tires: Tubeless or tubed, alternate sizes. Dual rear. Special treads. Underslung bar type tire carrier. Tire lock.

Transmission: Four-speed synchromesh. Reductions — low, 6.398 to 1; second, 3.092 to 1; third, 1.686 to 1; high, direct; reverse, 7.82 to 1.

Transmission, Automatic: Torque converter type. Three speeds forward, one reverse. Gear drive range selector mounted on steering column has Park, Reverse, Neutral, Drive², Drive¹, and Low positions. Eliminates need for clutch and pedal . . . Oil cooling unit.

Specifications subject to change without notice.

INTERNATIONAL HARVESTER COMPANY
180 NORTH MICHIGAN AVE. • CHICAGO 1, ILLINOIS

