

'75 International. The Other Pickup.



INTERNATIONAL HARVESTER

Bonus-Load 150. Meet the all-around, all-American pickup from International. This truck-tough, smooth riding performer will make life easier for you. For fun. Work. Personal transportation. Shopping. Whatever. It handles so easily, your wife will love driving it.

The Other Pickup has a wider track than any pickup on the road: tread width—67 inches. Plus independent coil-spring front suspension, rugged U-channel frame, big rear leaf springs, and a carlike ride. And you get a choice of a 6½- or 8-foot pickup box. Standard features include electronic ignition, power front disc brakes, closed cooling system, and heavy-wall exhaust pipes with an aluminized muffler.

Selective 4-wheel drive. Add International's selective 4-wheel drive, and you're set for some of the toughest kind of off-road driving, and able to maintain stability and control on iced or rain-slicked highways.

Selective 4-wheel drive with locking hubs means you use it only when you need it. There's less wear and tear on front drive components. And you save gas when you're not using 4-wheel drive because the engine isn't turning mechanical parts in the front axle.

Order selective 4-wheel drive with automatic or manual locking hubs: with automatic locking hubs you can engage the driving front axle from inside your pickup .

Bonus-Load 200. Put a camper on The Other Pickup, and get away for a weekend, a week, as long as you like. It's built to take extra-heavy cargo over the roughest kind of terrain. It has high-capacity axles, suspension, and tires, and you can get up to 9000-GVW rating. The pickup box has double-sidewall strength, and the hood is double-paneled for rigidity and resistance to flutter.

Don't get the idea the 200 is just for carrying campers. It can do everything our 150 Series can do; it's just designed to handle more load. Your International dealer will help you meet your needs.

Travelette. Now you can combine work and play in one multi-purpose vehicle. The Travelette is part wagon, part truck, with the best parts of both. On top of a sturdy truck frame and suspension, there's a wagonlike body that holds up to six adults comfortably . . . plus a full size pickup box.

The Travelette is ideal for families who like to pull a big fifth-wheel trailer or tote a big camper. Order your Travelette with a 6½- or 8-foot pickup box. And every box features a one-hand, swing-down tailgate for easy loading.



Choice of Comanche 304-cubic-inch V-8 engine; 345-cubic-inch V-8 engine; 392-cubic-inch V8 engine.

Setback engine for better cooling, less fan noise.

Large window area gives driver excellent visibility.

Anti-penetration, collapsible steering column increases your safety in case of collision.

All-steel gas tank is outside cab for safety.

Double-wall pickup box construction for extra strength.

Single paddle release on tailgate for easy, one-hand operation.

Staggered rear shocks to reduce "power hop."

Double-panel hood for extra strength and reduction of flutter.

Electronic ignition system eliminates points and condensers and increases spark plug life.

67-inch wide-front track increases road stability and allows more angle for short 42-foot turning diameter.

3-speed fully synchronized manual transmission is standard. 3-speed automatic transmission and 4-speed fully synchronized manual transmission are optional. 2-speed transfer case is optional with selective 4-wheel drive.

Independent front coil springs for smooth ride.

Power front disc brakes for more stopping power and less fade.

Extra side struts maintain wheel alignment.

All-steel deep-channel frame to withstand hard use.

Two rubber-cushion mounts in each front corner absorb shocks and vibrations.

Underlung rear springs give a lower center of gravity.

Three-pass aluminized muffler for long life. Wire-wrapped brake lines for protection against rocks, road debris, etc.

Widest-riding Pickup. A 67-inch front track gives The Other Pickup the widest track of any pickup on the road. The wider wheel location allows more angle for short 42-foot turning diameter. We combine the wider track with independent coil spring suspension for improved roll stability, handling, and riding performance.

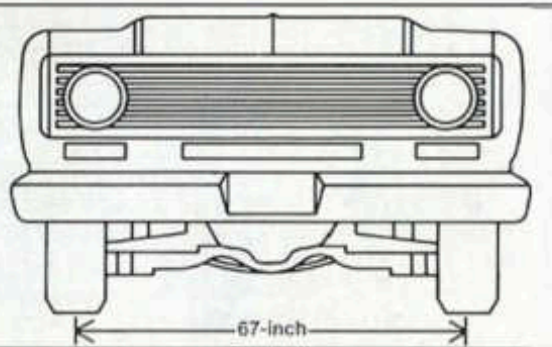

Engineered for the tough life. The Other Pickup is engineered for performance, endurance, and reliability. Whether you drive in-town, on-highway, or off-road, it's built to take lots of punishment. Standard features include heavy-duty components in chassis and engine. Tough U-channel steel frame. Heavy-duty springs, axles, shocks, and brakes. Precision-balanced crankshaft and hydraulic lifters. Oil pumps with cast iron housings. A close look at the photographic illustration will show you why The Other Pickup is truck-tough yet rides like a car.

The Other Pickup helps you get a lot more out of life.

It's built like a truck, drives like a car, and lets you have as much fun as a sports car. Whether you're loading up food and beverages for a family picnic, driving off-road to catch some scenery, or throwing on a couple of motorcycles, bicycles, or surfboards for outdoor sport, The Other Pickup helps make life a lot more fun.

But The Other Pickup has a practical side. It's the perfect vehicle for hauling a new freezer home from the appliance store. Or for borrowing and returning a tractor mower in case yours is out for repairs. For carrying a few dozen sheets of plywood or plywood paneling home for that modernization job.

For work, play, or just plain personal transportation, no other vehicle will give you the versatility, satisfaction, comfort, and durability of The Other Pickup.





Interior trim.

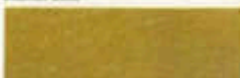

Marlin trim.



Sage.



Dark Red.



Dark Blue.



Jet Black.

Exterior color accents.



Deluxe exterior. Bright-finish side stripe matching with inset black trim; bright-finish windshield, vinyl rings, door molding; bright-finish wheel covers on Model 100 and bright-finish hub caps on Model 200; chrome front bumper; bright-finish, door-mounted rearview mirrors and stop/tail light bezel; aluminum tailgate insert.



Custom exterior. Two types of custom exterior trim. One type is the color of your choice in the side body panels. The other type is any color you want under the rocker panel trim strip and extending along the wheel wells and across the lower front of the pickup.



Optional roof. Dress up your pickup with a softy black or white simulated vinyl roof. Or if you prefer, get a roof painted in the color of your choice.

Inside The Other Pickup. Interiors are a pretty personal thing, so we want you to have the option of selecting an interior that suits your requirements and taste. That's why we offer you a choice of three interiors and four interior trim colors. We also offer a seating option of bucket seats which are not shown. Bucket seats are available with standard, deluxe, and custom interiors. A center storage console is included with bucket seats at no extra cost.



Custom interior. (Above two photos.) Big-car luxury. Thick nylon carpet for floor and kick panels. Electric window. Day/night mirror. Dual electric horns. Padded horn button. Parking brake warning light. Plus a lighting package that's legs in convenience and utility: underhood light, map light, glove box light, lighted control knobs, lighted ash tray, and rear cargo area light.

Standard interior. The foam-padded bench seat is upholstered with soft, long-wearing vinyl in a choice of four eye-pleasing, restful colors. Seat and cab interior are engineered to give up to three adults plenty of head, shoulder, hip, and leg room. You get an easy-to-read, fully instrumented padded dash, dual full-sized padded armrests and sunshades, roomy glove box, padded door release handles, wide-angle breakaway inside mirror, and a quiet, efficient fresh air heater/dehumidifier system.



Deluxe interior. Bench seat is covered with durable, easy-to-clean nylon trimmed in rich vinyl. Complete with color-keyed vinyl floor covering and soft-padded vinyl door panels. It also features door-operated dome light, cigar lighter, coat hook, and glove compartment lock.

Options to make it your personal pickup. Nobody knows better than you how much utility, convenience, and luxury you want in a pickup. We have all the options you need to customize your pickup to your requirements. After you decide on the personal options, like exterior and interior colors, type of radio, air conditioning, selective 4-wheel drive, power steering, auto-cruise control, etc., your International truck specialist is ready to help you select the proper V-8 engine, transmission, axle ratio, and GVW package. At International, we believe in matching the pickup to the man. We put the right truck in the right hands—yours.

Air conditioning. Relieve summer heat. The Other Pickup's air conditioning system provides fast, quiet, constant cooling.



Anti-skid brakes. If you start to skid when you apply brakes, anti-skid system automatically takes over and keeps the wheels from locking to assure a safer straight line stop.



AM or AM/FM radios. Take your choice of great sounding AM or AM/FM factory installed radios. For added enjoyment, ask your dealer to install an 8-track stereo tape player.



Selective 4-wheel drive/2-speed transfer case. We believe selective 4-wheel drive with locking hubs is the most practical and economical all-wheel drive system you can buy. You use it only when you need it. Which means less wear and tear on front driving components. And you save gas when you're not using 4-wheel drive because the engine doesn't have to turn mechanical parts in the front axle. The 2-speed transfer case gives you the slow-speed deep-reduction capability you need for climbing steep grades, snow-plowing, hauling heavy loads over rough terrain, or driving through deep mud, sand, snow, or ice.



Sliding rear window. Not only do you get more ventilation when you want it, but it makes communications between cab and camper much easier. Included in camper special option package.



Rear step bumper. Heavy-duty step bumper with trailer-hitch mount and trailer wiring. Makes it easier to get in and out of cargo bed when loading and unloading.



Camper special package. Just the thing when you want to get away from the crowd. A complete package that includes heavy-duty cooling and heavy-duty electrical components. Rear sway bar. Underslung tire carrier. Auxiliary fuel tank. 61-amp alternator and 73-amp/hr battery. Dual exhaust with long tail pipes. Sliding rear window. Dual low profile mirrors. 7-way camper wiring (less connector). Camper decal.



Tilt steering wheel. Seven positions for true driving comfort. Just flip a lever, and you can adjust your steering wheel to your most comfortable driving position. Adjust it again for easier entry and exit.



Slide-in toolbox. Add the convenience of this weather-resistant, made-to-fit toolbox. Built-in paddle locks. Dealer installed.



Camper insert stabilizer. Maximizes control of slide-away and forward- and backward-lurching motions. Attaches permanently to overhang of camper, and swings up and locks out of the way for storage. Adjustable length of 26 inches to 36 inches. Dealer installed.



Auto-cruise speed control. Automatically maintains speed at rate you prefer. Ideal for thruway driving. Gas-saver on long trips.



Auxiliary fuel tank. Extend the range of your pickup by ordering an auxiliary fuel tank.



Cargo light. Now you can load or unload at night with perfect safety. Part of lighting package included with custom interior.

Other options and accessories. Underslung tire carrier. Optional axle ratio. Automatic transmission. Power steering. Trailer-losing package. Tonnau cover. Pickup rails. Bumper guards.

Specifications.

Series	150		200		150-4x4		200-4x4		300 TRAVELETTE	
	STANDARD	OPTIONAL	STANDARD	OPTIONAL	STANDARD	OPTIONAL	STANDARD	OPTIONAL	STANDARD	OPTIONAL
GVM Ratings (lbs.)	4200	4500	4200	PSI, 1500-2000, 3000	4200	5000	4300	5000	4300	5000
Engines	V-6	V-304A	V-304A	V-304A	V-304A	V-304A	V-304A	V-304A	V-304A	V-304A
Clutch	11" Diaphragm	11" Angle Line	11" Diaphragm	11" Angle Line	11" Diaphragm	11" Angle Line	11" Diaphragm	11" Angle Line	11" Diaphragm	11" Angle Line
Front Suspension	Independent Coil Spring		Independent Coil Spring		Driving Hybrid w/Leaf Springs		Driving Hybrid w/Leaf Springs		Independent Coil Spring	
Chassis	3000	—	3400	—	3400	—	3600	—	4000	3800
Chassis Cap. (lbs.)	2400	—	2400	—	2400	—	2400	—	2400	2400
Spring-Cap. (lbs.)	1" Dia.	1 1/2" Dia.	1 1/2" Dia.	1 1/2" Dia.	1 1/2" Dia.	1 1/2" Dia.	1 1/2" Dia.	1 1/2" Dia.	1 1/2" Dia.	1 1/2" Dia.
Shock Absorbers	—	—	—	—	—	—	—	—	—	—
Stabilizer Bar	—	—	—	—	—	—	—	—	—	—
Rear Suspension	Full Floating Hybrid Single Reduction		Full Floating Hybrid Single Reduction		Semi Floating Hybrid Single Reduction		Semi Floating Hybrid Single Reduction		Full Floating Hybrid Single Reduction	
Chassis Cap. (lbs.)	3000	3000	3500	3500	3000	3000	3500	3500	3000	3000
Chassis	3.50	3.57	3.54	3.57	3.57	3.57	3.54	3.57	3.54	3.57
Balance	3.25	3.54	3.54	3.54	3.31	3.54	3.54	3.54	3.54	3.54
Spring-Type	Leaf Springs	Leaf Springs w/ Auxiliary	Leaf Springs	Leaf Springs w/ Auxiliary	Leaf Springs	Leaf Springs w/ Auxiliary	Leaf Springs	Leaf Springs w/ Auxiliary	Leaf Springs w/ Auxiliary	Leaf Springs w/ Auxiliary
Spring-Cap. (lbs.)	3000	3000	4000	4000	3000	3000	4000	4000	4000	4000
Shock Absorbers	1" Dia.	1 1/2" Dia.	1" Dia.	1 1/2" Dia.	1 1/2" Dia.	1 1/2" Dia.	1 1/2" Dia.	1 1/2" Dia.	1 1/2" Dia.	1 1/2" Dia.
Brakes	Front/Rear Power Disc/Drum	Front/Rear Power Disc/Drum	Front/Rear Power Disc/Drum	Front/Rear Power Disc/Drum	Front/Rear Power Disc/Drum	Front/Rear Power Disc/Drum	Front/Rear Power Disc/Drum	Front/Rear Power Disc/Drum	Front/Rear Power Disc/Drum	Front/Rear Power Disc/Drum
Electrical	Battery/AMP. Alternator/AMP.	35/47	35/47	35/47	35/47	35/47	35/47	35/47	35/47	35/47
Fuel Tank	Normal Capacity (gal.)	16	16	16	16	16	16	16	16	16
Steering	Manual	Manual	Manual	Manual	Manual	Manual	Manual	Manual	Manual	Manual
Transmissions	3-Speed Synch. Manual	4-Speed Synch. Manual	3-Speed Synch. Manual	4-Speed Synch. Manual	3-Speed Synch. Manual	4-Speed Synch. Manual	3-Speed Synch. Manual	4-Speed Synch. Manual	3-Speed Synch. Manual	4-Speed Synch. Manual
Transfer Case	—	—	—	—	—	—	—	—	—	—
Tires	Tubetype Tires—Size	H10415 LRD	—	800x16 S LRD	—	800x16 S LRD	—	800x16 S LRD	—	800x16 S LRD

*Optional tires available based on gross vehicle weight rating.

Engine Specifications	Compact V-304	V-304	V-302
Displacement (cu. in.)	300	345	300
Bore & Stroke (in.)	3 1/2" x 3 1/2"	3 1/2" x 3 1/2"	4 1/2" x 3 1/2"
Compression Ratio	8.75 to 1	8.50 to 1	8.00 to 1
Max. Rev. Torque @ RPM	141 @ 4200	158 @ 3600	172 @ 3600
Max. Net Torque (lbs./ft.) @ RPM	243 @ 2400	268 @ 2100	288 @ 2400

Model	1975 International® Pickup® Specifications		
	150	200	Travlette
Wheelbase	119" 132"	119" 132"	119"
Overall Length	204 218"	204 218"	204 218"
Overall Width	75 75"	75 75"	75 75"
Tailgate Opening	50"	50"	50"
Front Tread	57 57"	44 44"	57 57"
Rear Tread	48 48"	48 48"	48 48"
Ground Clearance (minimum)	5.8" h. & 3.1" f.	6.0" h. & 3.7" f.	7.7" h. & 7.0" f.
Turning Diameter (minimum)	40 40"	41 41"	41 41"

Exterior colors.



Bluish Blue Metallic.



Burnished Gold Metallic.



Red.



Flame Red.

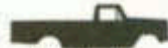

Dark Green Affair.



Gold Metallic.



Onaka Orange.



School Bus Yellow.



Glacier Blue.



Winter White.



Sunburst Yellow.



Pewter Metallic.



Granite Green.



Dark Brown Metallic.



Buckskin.



Fire Orange.



Terra Cotta.



Specifications, descriptions, photographs, and illustrative material in this literature are as accurate as known at time of publication, but are subject to change without notice. Photographs and illustrations may include optional equipment and accessories and may not include all standard equipment.