

1978 International

Scout[®] II

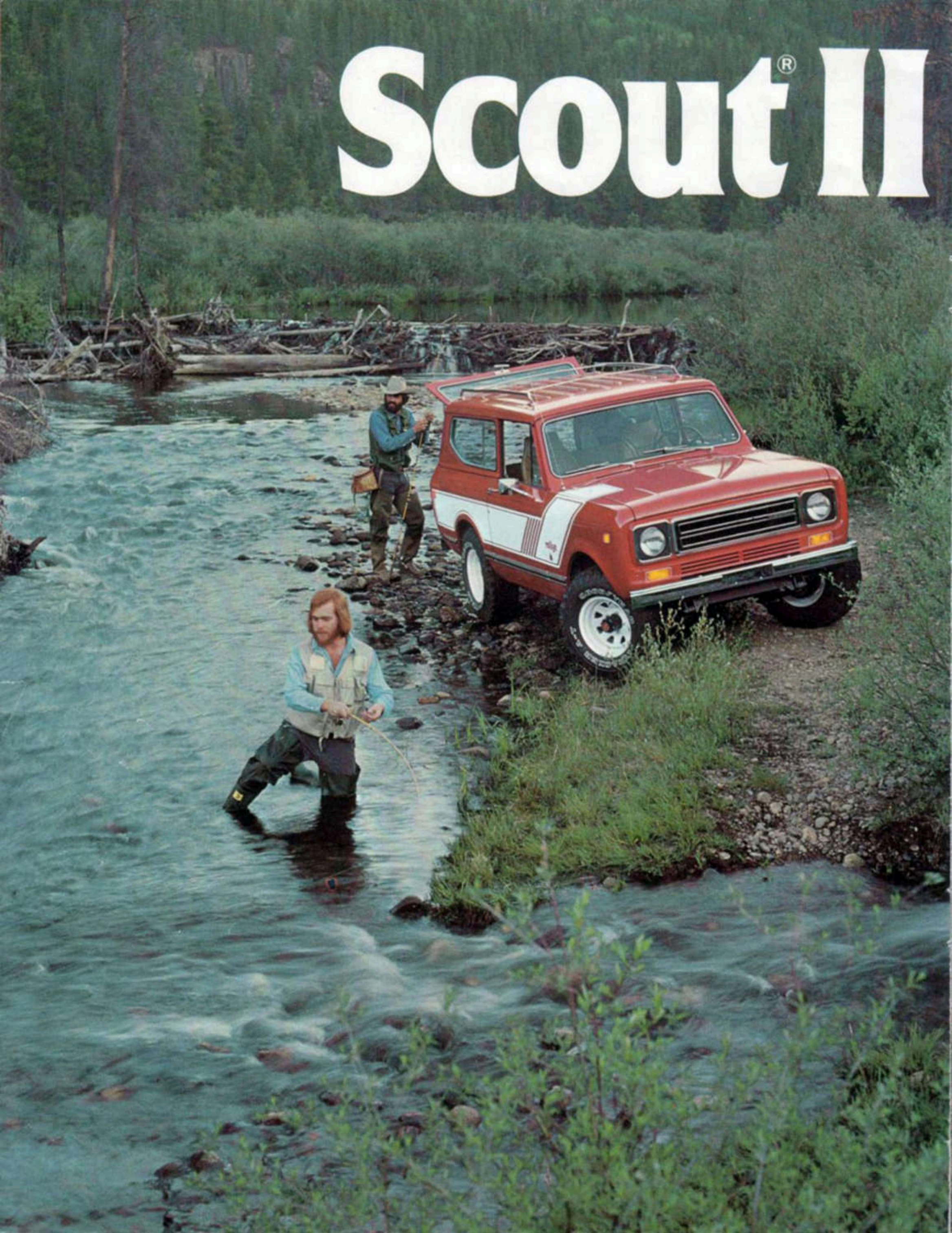

Scout II[®]



Tough 4-wheel drive Scout II. It has what it takes to get you there.



America's a big country. And much of it is hard to reach in an ordinary vehicle. So jump into a Scout II and scout the America you've been missing too long. High, winding mountain side roads. White water. Brawling rivers. Clean, sparkling lakes. Desert country.

Tough, durable, maneuverable, Scout has the raw power and stamina to take you almost anywhere you want to go. Easily. Comfortably. Safely. You could say it's your "freedom machine."

Dash-mounted 4-wheel drive controls.

The tougher the going, the more you'll appreciate Scout II's exclusive dash-mounted 4-wheel drive engagement knob or optional lever-controlled two-speed transfer case. Optional automatic locking hubs mean you don't have to get out in the mud, rain, or snow to get 4-wheelin'.



We build them tough all the way through.

We know what you want in a 4-wheel drive machine. A rugged, durable, gutsy, solid performer that can stand up to the toughest kind of off-road driving conditions. And Scout II gives it to you. Precision engineered, it has a body that's all-steel welded construction, powerful disc brakes in front that maintain straight-line control during heavy braking, self-adjusting drums in the rear, and a choice of three hard-charging gasoline engines or an economical diesel. A big 11-inch clutch and an easy-to-read functional instrument center are standard.

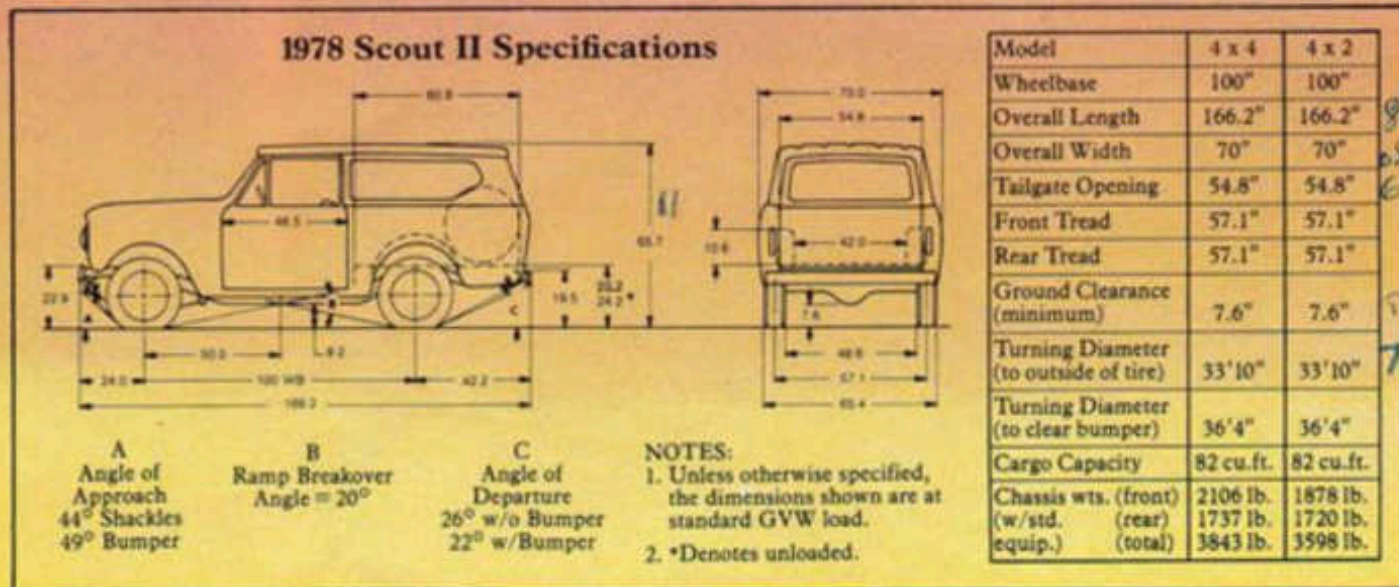

For protection against weather and chemicals in the air, the body of each Scout II goes through a very special rust prevention primer process. New electrostatic spraying techniques allow for smooth, even paint coverage. Why do we put so much into Scout II? So you can demand more out of it, and get it.

Direct-reading gauges include: temperature, ammeter, speedometer, oil pressure and fuel. All located in front of driver for easy visibility.

100-in. wheelbase means great off-the-road mobility and maneuverability.

Dash-mounted courtesy lights.

Optional second seat provides rear passengers with a maximum of 33.4 in. leg room.

Spacious cargo area is 60.8 in. long and 54.8 in. wide. Has 82-cu.-ft. capacity. With the tailgate open, you have a large 40-in. x 54.8-in. rear opening for convenient loading.

Sturdy steel roof is removable.

Optional seven-position steering wheel allows easy entrance and exit and adjusts for personal driving comfort.

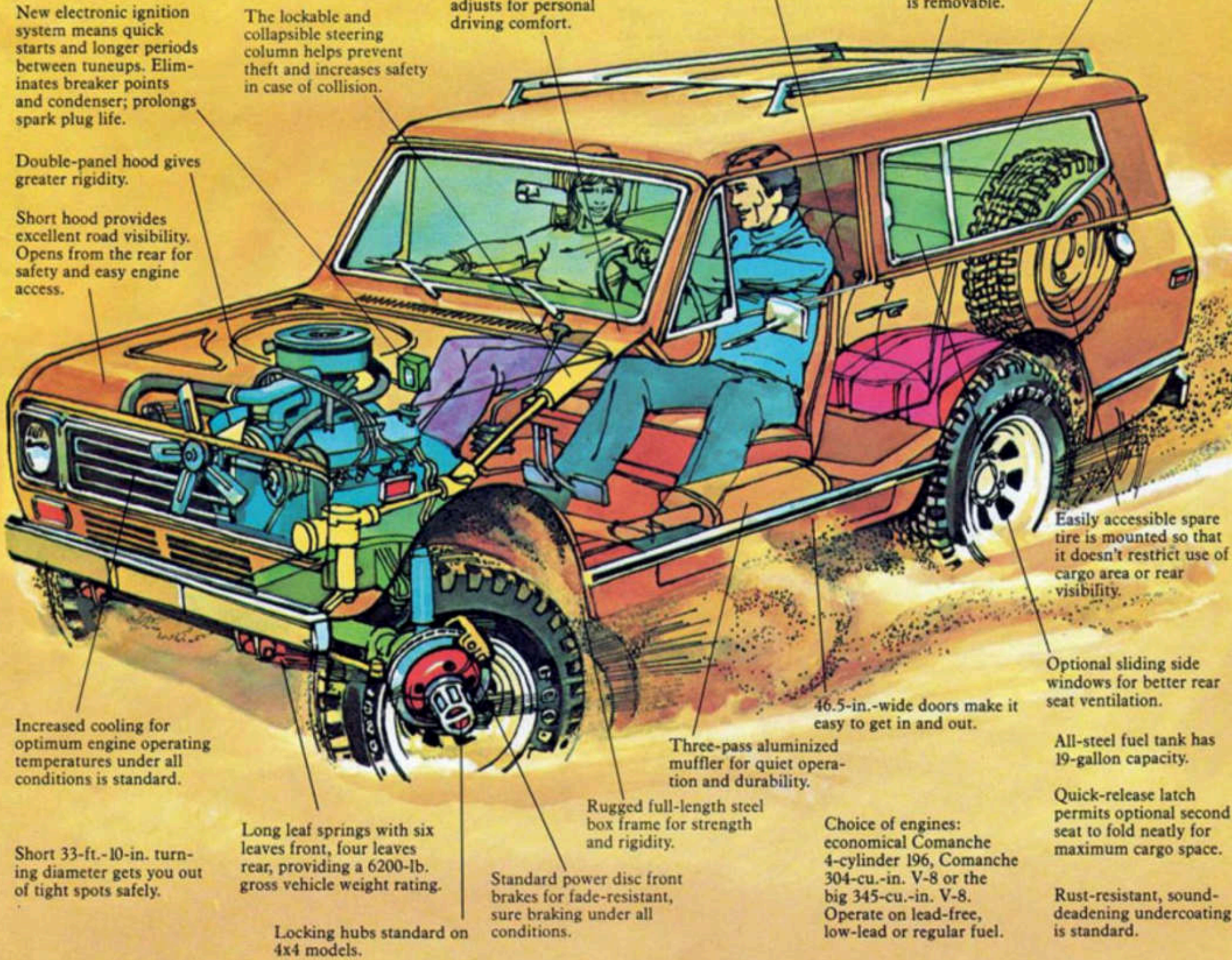

New electronic ignition system means quick starts and longer periods between tuneups. Eliminates breaker points and condenser; prolongs spark plug life.

The lockable and collapsible steering column helps prevent theft and increases safety in case of collision.

Double-panel hood gives greater rigidity.

Short hood provides excellent road visibility. Opens from the rear for safety and easy engine access.

Increased cooling for optimum engine operating temperatures under all conditions is standard.

Short 33-ft.-10-in. turning diameter gets you out of tight spots safely.

Long leaf springs with six leaves front, four leaves rear, providing a 6200-lb. gross vehicle weight rating.

Locking hubs standard on 4x4 models.

Optional seven-position steering wheel allows easy entrance and exit and adjusts for personal driving comfort.

Rugged full-length steel box frame for strength and rigidity.

Standard power disc front brakes for fade-resistant, sure braking under all conditions.

100-in. wheelbase means great off-the-road mobility and maneuverability.

Dash-mounted courtesy lights.

Optional second seat provides rear passengers with a maximum of 33.4 in. leg room.

Sturdy steel roof is removable.

46.5-in.-wide doors make it easy to get in and out.

Three-pass aluminized muffler for quiet operation and durability.

Choice of engines: economical Comanche 4-cylinder 196, Comanche 304-cu.-in. V-8 or the big 345-cu.-in. V-8. Operate on lead-free, low-lead or regular fuel.

Spacious cargo area is 60.8 in. long and 54.8 in. wide. Has 82-cu.-ft. capacity. With the tailgate open, you have a large 40-in. x 54.8-in. rear opening for convenient loading.

Easily accessible spare tire is mounted so that it doesn't restrict use of cargo area or rear visibility.

Optional sliding side windows for better rear seat ventilation.

All-steel fuel tank has 19-gallon capacity.

Quick-release latch permits optional second seat to fold neatly for maximum cargo space.

Rust-resistant, sound-deadening undercoating is standard.



Custom interior — shown with optional bucket seats and console.



Deluxe interior — shown with optional bucket seats and console.



Standard interior — shown with standard one-third/two-thirds bench seat.



A world of space with the optional folding rear seat down.

Interior trim:



Standard
Tanbark Vinyl

Tanbark
Vinyl/Nylon

Saddle
Custom Vinyl

Wedgewood Blue
Vinyl/Nylon

Parchment
Custom Vinyl

Scout Interiors. It makes getting there half the fun.

When you're driving all day in the boonies, you'll appreciate Scout comfort. Whether you select the standard interior, the impressive deluxe, or the luxurious custom, you'll go in style. Choose from five easy-on-the-eyes interior trims and good-looking, easy-care, all-vinyl upholstery or handsome, long-lasting vinyl/nylon upholstery. Standard bench seats and optional bucket seats have firm, deep-foam cushioning.

Even the standard interior is equipped with a fully instrumented dash, tinted glass, full front seat, courtesy lights, big glove compartment, color-keyed vinyl floor mats, and padded sun visors and armrests.

Whatever interior you pick, you'll find out that getting there is half the fun. Suddenly, it's fun to drive again.

Options to make the machine fit your style.

Man or woman, you want a Scout that fits your lifestyle. The way you work. And play. The places you've always wanted to go, the things you've always wanted to do. We've got the options to make a Scout just right for you. Take a look at the list of options on the left. Then choose the ones that'll give you more comfort, fun, and versatility. Scout options. They'll help you get more out of life.



Automatic locking hubs. They'll get you 4-wheeling without getting out in the weather.



Three-speed automatic transmission. Smooth, efficient three-speed automatic transmission lets you lean back and enjoy the ride.



10-15 LT LRB tires. These big, rugged tires deliver superb traction on the toughest kind of off-road situations.



Air conditioning. Keep your cool with Scout's air conditioning package. It includes a 390 CCA 12-volt battery and 61-amp alternator, and variable temperature and fan control.

AM/FM radios. Choose your sound system from a variety of factory-installed AM or AM/FM radios. And your Scout dealer can install a great sounding 8-track stereo tape player.



Cruise control. Sit back and relax while fuel-efficient cruise control with resume-speed feature takes over on those long highway stretches.



Luggage rack. Although you can haul a big load inside, the chrome luggage rack with adjustable crossbars lets you carry some more on the outside.



Seven-position tilt steering wheel. Adjustable so a driver can select a comfortable position; easier to enter and exit.



Sliding rear quarter windows. Open the sliding side windows and cool off naturally.



Heavy-duty rear step bumper. Tow up to 2000 lbs. smoothly and easily. And the step bumper makes it a cinch to load up the luggage rack.



The outside says a lot about the man inside.

If you weren't a special kind of person, you wouldn't be driving a Scout. We know that, so we paint Scout with colors that say action, color, excitement. Nine vibrant colors that are close to nature. And a selection of five sporty appliques to personalize it. You're never just part of the crowd in a Scout. You're above it.

Exterior accents with dash.



White side panels.



White accent stripe.



Black side panels.



Woodgrain side panels.



Rallye white applique. Available only with Rallye package.*

*Rallye option consists of hood and side applique, 1 1/2-inch-diameter heavy-duty shock absorbers, power steering, and choice of chrome slotted rims with steel belted radial tires or white spoke rims with on-off hi-way tires.

1978 exterior colors

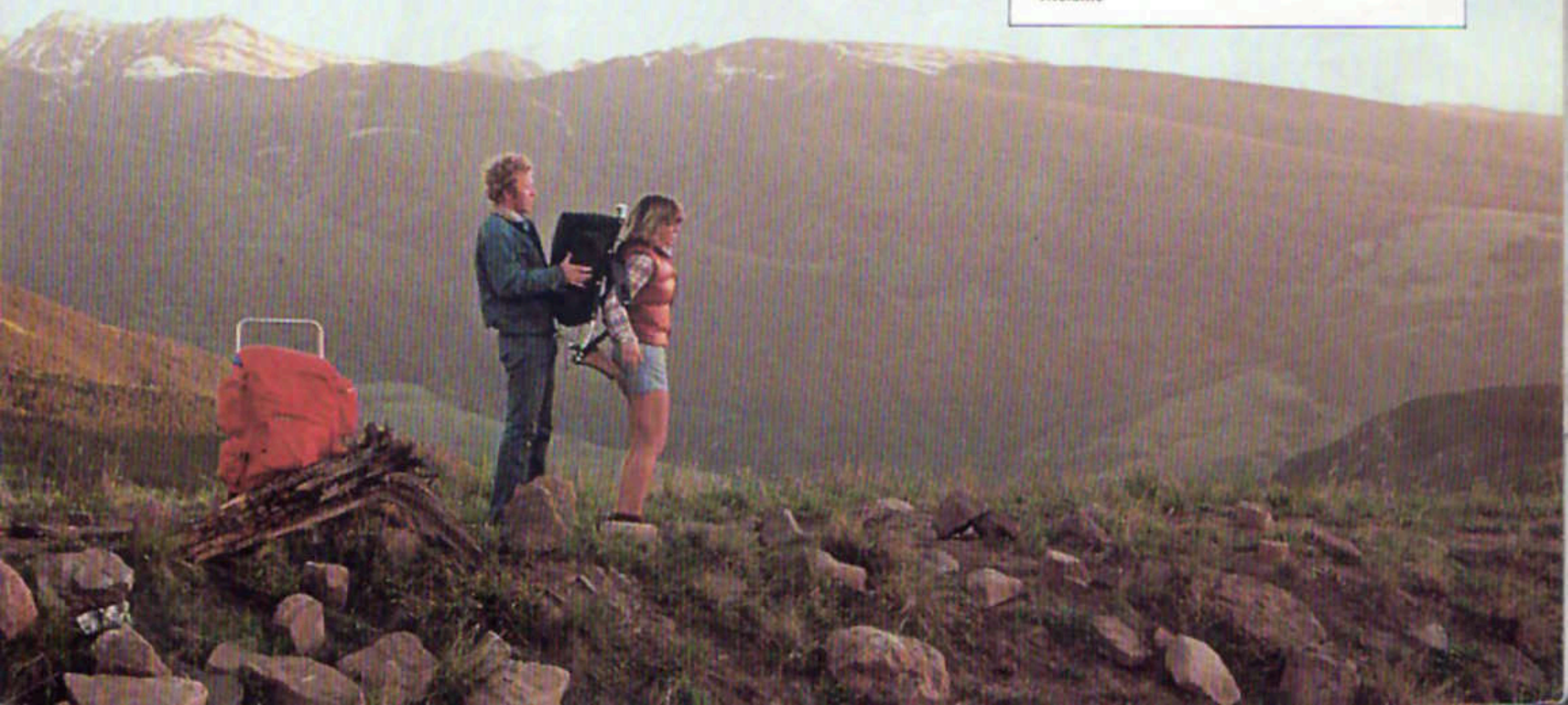

Chassis Specifications

		STANDARD	OPTIONAL
GVW Ratings (lb.)		6200	
Clutch		11" Angle Link	11" Angle Link H.D.
Front Suspension	Axle Type/Cap. (lb.)	4x2 - FA-3 Tubular Steel/3100 4x4 - FA-44 Driving Hypoid/3200	
	Springs Type/Cap. (lb.)	Leaf/3100	H.D. Leaf/3200
	Shock Absorbers	1" Diam.	1 1/8" Diam H.D.
	Stabilizer Bar	Front	
Rear Suspension	Axle Type/Cap. (lb.)	Semifloating/3500	Semifloating w/Trac-Lok/3500
	Springs Type/Cap. (lb.)	Leaf/3100	H.D. Progressive Leaf/3100
	Shock Absorbers	1" Diam.	1 1/8" Diam./H.D.
Brakes		Power Disc/Drum	
Electrical	Battery CCA	300	390 or 500
	Alternator (amp.)	37	61
Fuel Tank	Nominal Capacity (gal.)	19	
Steering	Type	Manual	Integral Power
Transfer Case		Single-Speed "Silent Drive"	2-Speed Gear Drive
Tires	Tubeless	H78x15 LRB	H78x15 LRB WSW H78x15 LRB Mud/Snow H78x15 LRB Radial WSW HR78x15 LRB Radial WSW 10-15 LT LRB On-Off Hi-way White Letter
	Tube Type		700x15 LRC Regular Tread 700x15 LRC Mud/Snow

Drive Train Combinations

Engine	Transmission	Axle Ratios	
		Standard	Optional
Comanche 4-Cylinder: 4-196	3-Speed Manual Fully Synchronized (Standard)	4.09	
	4-Speed Manual Fully Synchronized Wide Ratio (4x4 Models only)	4.09	3.54 3.73
	4-Speed Manual Fully Synchronized Close Ratio	3.54	3.73 4.09
	3-Speed Automatic		
V-8's: V-304 and V-345	3-Speed Manual Fully Synchronized (Standard)	3.54	3.73 4.09 w/V-304 only
	4-Speed Manual Fully Synchronized Wide Ratio (4x4 Models only)		
	4-Speed Manual Fully Synchronized Close Ratio	3.07	3.54 3.73 4.09 w/V-304 only
	3-Speed Automatic		

Engine Specifications

	Comanche 4-196	Comanche V-8 304A	V-8 345A
Displacement (cu.in.)	196	304	345
Bore & Stroke (in.)	4 1/8-3 1/2	3 1/4-3 1/2	3 1/4-3 1/2
Compression Ratio	8.02 to 1	8.19 to 1	8.05 to 1
SAE Net Horsepower* @ rpm	86 @ 3800	144 @ 3600	163 @ 3600
SAE Net Torque* (lb./ft.) @ rpm	157 @ 2200	247 @ 2400	292 @ 2000
SAE Net Horsepower** @ rpm	79 @ 3600	N/A	138.5 @ 3400
SAE Net Torque** (lb./ft.) @ rpm	155 @ 2000	N/A	271 @ 2000

*For all states except California

**California only

1978 Trailer Towing Recommendations

Minimum Requirements

Class	I	II	III
Loaded Trailer Weight	Up to 2000 lb.	2000 lb. to 3500 lb.	3500 lb. to 5000 lb.
Max. Gross Combined Weight	6700 lb.	8200 lb.	10,000 lb.
Trailer Hitch Type	H.D. Step Bumper	Equalizer Type	Equalizer Type
Max. Tongue Load	300 lb.	15% of Gross Trailer Weight	15% of Gross Trailer Weight
Transmission (Automatic)	T-407	T-407	T-407
Transmission (Manual)	T-332, 3-Speed w/Heavy-Duty Clutch	T-428 Close Ratio 4-Speed w/Heavy-Duty Clutch	T-428 Close Ratio 4-Speed w/Heavy-Duty Clutch
Tires	H78x15 LRB Standard	H78x15 LRB Standard	HR78x15 LRB Radial
Battery	300 CCA Standard	390 CCA w/Towing Pkg.	390 CCA w/Towing Pkg.
Alternator 6-Way Wiring	37 amp. Recommended	61 amp. w/Towing Pkg.	61 amp. w/Towing Pkg.
Heavy-Duty Closed Cooling System	Standard	Standard	Standard
Power Brakes (Disc Front)	Standard	Standard	Standard
Power Steering	Not Required	Recommended	Recommended

Engine/Axle Ratio Guidelines for Towing

Engine	Total Combined Weight, lb.				
	6200	7000	8000	9000	10000
V304	3.07	3.54	3.73	4.09	N.R.
V345	3.07		3.54	3.73	



INTERNATIONAL HARVESTER

Scout leads the way.

Specifications, descriptions, photographic and illustrative material in this literature are as accurate as known at time of publication but are subject to change without notice. Photographs and illustrations may include optional equipment and accessories and may not include all standard equipment.

AD-40587-F1

Lithographed in United States of America.