



MASERATI



*Quattroporte*



*Quattroporte*

The New Quattroporte. By Maserati.

## Over 100 years of defiance and glory.

On 1<sup>st</sup> December 1914, Alfieri, Ernesto and Ettore Maserati, set up their own business in Bologna, modifying Isotta Fraschinis for road racing. By 1926, they had produced their own racing car, the Maserati Tipo 26, which promptly won its class in the Targa Florio of that year. In the 1930s, '40s and '50s, Maserati enjoyed success after success on the racetrack, with wins that included two Indianapolis 500s, 29 victories in Formula 1, and the 1957 F1 World Championship, won by Fangio driving a 250F. 1947 saw the company turn its attention to the manufacture of passenger cars with the inspirational Maserati A6 grand tourer, followed in 1957 by the 3500 GT 2+2 sports coupé that introduced a number of important innovations, such as twin-spark ignition, disc brakes and fuel injection.

In 1963, Maserati showcased the world's first luxury four-door sports sedan the Quattroporte and, in the late '60s and '70s, launched a series of ultra-high performance supercars, the Mistral, Ghibli, Khamsin, and Bora. After several changes in ownership, Fiat acquired Maserati in 1993, giving it the financial stability that would secure its future. Now an autonomous division within Fiat Chrysler Automobiles, Maserati boasts a class-leading range that covers the entire luxury sector of the international car market, and is seeing ever-growing interest in the legendary 'Marque of the Trident'.

# HISTORY





Quattroporte.  
Race-bred engineering in a luxury sedan.  
Since 1963.

When Maserati presented the first Quattroporte at the 1963 Turin Motor Show, it not only launched the fastest four-door car in the world, but also introduced a whole new category to the marketplace: the luxury sports sedan. The concept was revolutionary for the times: take a successful Maserati racing engine and place it inside the body of a sedan; nobody had done it until then. With its exceptional handling and a race-bred V8 engine, the Quattroporte was capable of 130 mph even then.

In the following 50 years, the Quattroporte has remained as Maserati's flagship model. Forever exclusive, never mainstream, it has always been daringly different – for those who dare to be different.

The Quattroporte comes in many guises.  
Because choice is so important.

In the new Quattroporte, Maserati has created a unique and exclusive car, designed for the discerning tastes of entrepreneurial pioneers and business trailblazers – high achievers who relish the unconventional and avant-garde. Naturally, for such a demanding clientele, the Quattroporte is available in a number of different guises and with three inspirational engines.

The Quattroporte S comes with Maserati's awesome 410 HP 3.0 litre, twin-turbo V6 engine, whilst for those seeking the ultimate in traction, there is the Quattroporte S Q4, which features Maserati's highly acclaimed Q4 all-wheel drive system. However, if truly stupendous levels of power and performance are required, there can be only one solution: the uncompromising Quattroporte GTS, with its magnificent 3.8 litre twin-turbo V8 that produces an enormous 530 HP. Alternatively, diesel aficionados can opt for the Quattroporte Diesel and its decidedly sporty 275 HP 3.0 V6 turbo-diesel unit.

# RANGE





## The New Quattroporte. By Maserati.

It is an undisputed truth that Italians lead the world in car design, imbuing their cars not only with great beauty, but also adding that intangible touch of genius called 'allure'. A prime example of this is the Quattroporte: cultured and refined, it is a masterpiece of sophistication, aesthetics and aerodynamic elegance.

Despite its impressive size, the Quattroporte manages to maintain a balanced and dynamic appearance - from the restyled Maserati grille at the front to its LED light clusters at the rear. Newly designed front and rear bumpers give the car even greater authority and presence, whilst the marque's traditional three air vents are featured along the sides. Frameless doors then manage to give this executive saloon the appearance of a sleek coupé. The Quattroporte's familiar triangular C-pillar, with the celebrated Saetta logo, is another nod to the car's innate sporty character, as are the quad chrome tailpipes and the integral boot spoiler, which generates downforce at high speeds. Its aerodynamics are unsurpassed, thanks in part to its flat underbody and also to a clever Air Shutter behind the front grille that controls the passage of air through the radiator and reduces drag.

## In the front or in the rear, relax in the lap of luxury.

To ensure the comfort of its distinguished guests, the Quattroporte wants for nothing, and in terms of materials and equipment only the best will do: premium Italian leathers, fine woods, handcrafted stitching, the very latest in high-tech instrumentation and exclusive Ermenegildo Zegna Silk Edition interiors.

The sensation of wellbeing begins with the 12-way power adjustable leather front seats that ensure the perfect driving position. Ahead of the driver, on the central console, there is the very latest touch-screen infotainment system with an additional rotary control, along with a handy new phone storage box. Meanwhile, the multifunction steering wheel is a model of ergonomic efficiency and provides a highly tactile grip.

Equal attention has been focused on the occupants of the rear seats, as well. The standard Quattroporte comes with a supremely comfortable, asymmetrically folding, hand-stitched leather rear bench seat for three people, complete with a central armrest that contains a USB point and a 12V socket. The overall spaciousness of the Quattroporte is enhanced by the sleek lines of the broad dashboard, its central tunnel, and its large doors, so that all onboard are enveloped in an atmosphere of complete luxury.

# EXCLUSIVITY





# GRANLUSSO



## Irresistible style and enhanced exclusivity: GranLusso trim.

Those who seek even more exclusivity and lavish luxury in their Quattroporte can opt for the unrestrained opulence of the GranLusso trim, with an interior styled and appointed by the leading fashion house of Ermenegildo Zegna. Exquisite Italian Zegna silk, colours and top class materials combine to generate an absolute masterpiece of taste and refinement – Maserati being the only brand in the world to feature bespoke silk interiors. Other GranLusso enhancements to the cabin include a wood and leather steering wheel, wood trim, power foot pedals, a power rear sunblind, four-zone climate control, and heated rear seats. On the outside, for an even more luxurious look, the bumper inserts are in chrome, and there are body coloured sideskirts, black brake calipers and elegant 20" Mercurio wheels.





# GRANSPORT



## A sporty appearance all your own: GranSport trim.

For individuals of a sporting disposition who want their Quattroporte to reflect their more athletic lifestyles, there is the highly distinctive and dramatic GranSport trim. Exterior enhancements include front and rear new sports bumpers with exclusive black gloss features, body coloured sideskirts, 21" Titano wheels, and red brake callipers. Inside, the cabin benefits from special sports seats, gearshift paddles, Inox sport foot pedals, a new sports steering wheel, and Piano black trim.





# PERFORMANCE



## Performance under pressure.

At Maserati Powertrain, the engine developers' mission was to produce maximum power with minimum fuel consumption and emissions. Their solution: turbocharging, although in keeping with Maserati tradition, they decided to use not one turbocharger, but two - one for each cylinder bank. Maserati pioneered the use of two turbochargers in its 1981 Biturbo, an innovation that has only recently been adopted by the rest of the automotive industry.

With the mighty 410 HP 3.0 Twin Turbo V6 petrol engine, the Quattroporte S accelerates from 0 to 100 km/h in 5.1 seconds, and has a top speed of 286 km/h. However, for those who will settle for nothing less than the ultimate in power and performance, in the GTS there is Maserati's glorious 3.8 V8 engine, again featuring two turbochargers, that develops an enormous 530 HP and 710 Nm of torque, resulting in 0 to 100 km/h in 4.7 seconds and a top speed of 310 km/h. In keeping with the all-pervading sporting spirit of the brand, both petrol engines are hand-assembled by Ferrari at its Maranello plant.

When the going gets particularly tough, sometimes traction from all four wheels is required. That is when the Quattroporte S Q4 comes to the fore, providing its occupants with the highest levels of opulence on the inside, plus on-demand Q4 all-wheel drive to cope with more challenging conditions on the outside.

Alternatively, the Quattroporte is available with a highly innovative 3.0 V6 Turbo diesel, a veritable gem of an engine, boasting all the very latest in diesel technology, and a variable geometry turbocharger that minimizes turbo lag significantly. Its 275 HP and 600 Nm of torque enables it to surge from 0 to 100 km/h in just 6.4 seconds and reach a top speed of 252 km/h.

## Q4 intelligent all-wheel drive system. The power of *at-traction*.

Q4 all-wheel drive raises the thrill of driving a Quattroporte to new heights and delivers many other benefits, as well. The system manages to combine the legendary sports car performance of a Maserati with controlled and balanced handling in the snow and on ice.

The Q4 system is compact and lightweight, and continually analyses six parameters: driving style, steering angle, yaw angle, speed, wheel slip and power output. The distribution of drive torque is then varied accordingly. In normal conditions, Q4 sends all the engine's torque to the rear wheels, ensuring excellent driving dynamics and optimal fuel consumption. However, if the road surface turns slippery and grip starts to be lost, in just 150 milliseconds the intelligent all-wheel drive system transfers up to 50% of the power to the front wheels for maximum traction. Q4 therefore provides the best of both worlds: an exciting and dynamic drive in normal conditions, coupled with safety and security when needed. The Quattroporte S Q4 accelerates 0 to 100 km/h in 4.9 seconds and has a top speed of 286 km/h.

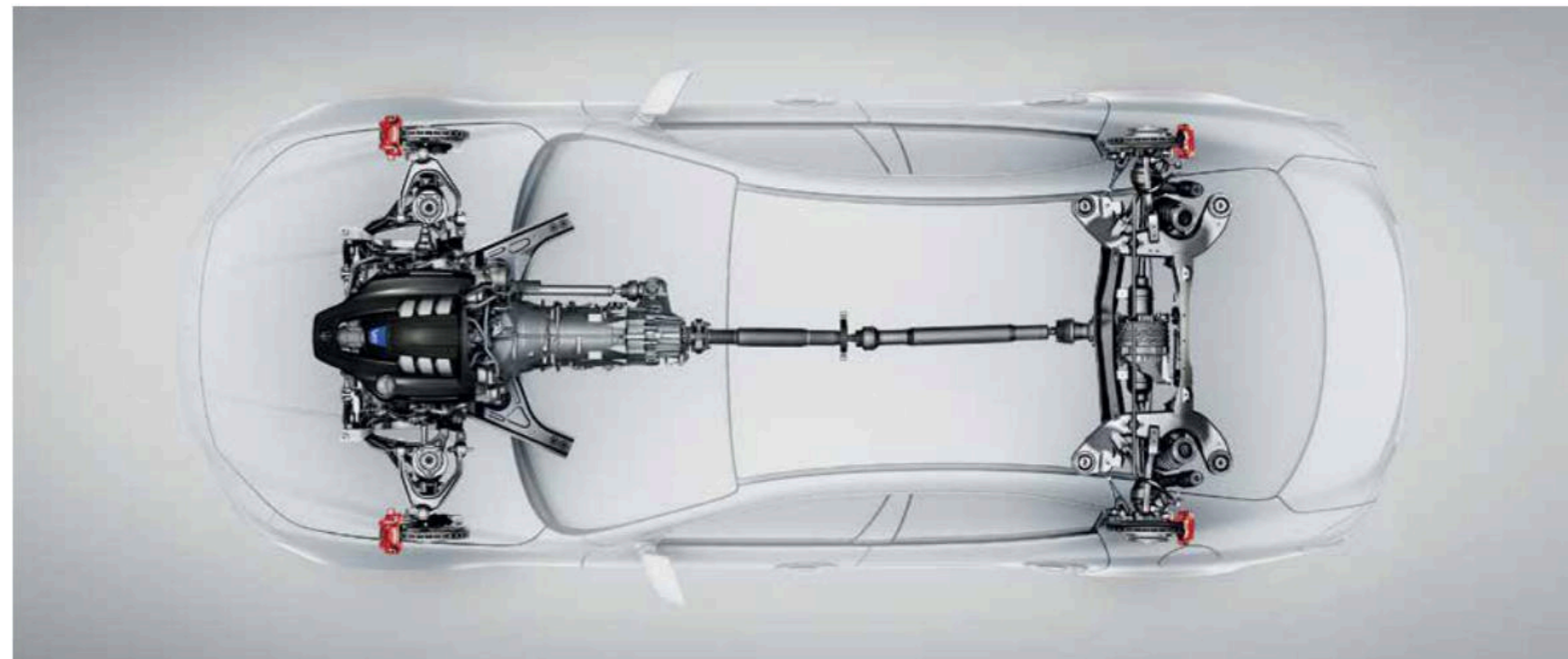

# TECHNOLOGY



## Eight-speed transmission and Skyhook suspension: supreme onboard comfort and sheer driving pleasure.

The sophisticated design of the eight-speed ZF automatic gearbox ensures precise gearchanges and exceptional performance, and comfortably manages the prodigious power of the different engines. Mounted behind the engine, it is assisted by auto-adaptive software that is able to recognise the way the car is being driven, and modifies the shifting pattern for each individual driver. There are five operating modes, selected using the buttons near the gear lever: Auto Normal, Auto Sport, Manual Normal, Manual Sport, and Increased Control & Efficiency (I.C.E) for a better control in any weather conditions and the most comfortable and quietest engine response, along with minimal fuel consumption. Upshifts are all automatic unless a manual mode is selected.

The Quattroporte offers the kind of intense driving pleasure for which the marque is famous, together with levels of handling prowess more normally associated with two-seater sports cars. Like every Maserati, it features an extremely sophisticated suspension set-up, which is combined with the latest version of the Skyhook electronic system that features continuous damping variation shock absorbers. The standard setting prioritises comfort, whereas for a more dynamic drive, the driver can press the suspension button, which stiffens the shock absorbers. In both modes, the Skyhook system stays active, and continuously adapts to the road to maximise traction.

## Priority number one: protection for all.

In designing the Quattroporte, Maserati made safety the number one priority. To provide the best possible protection for its occupants it features the latest-generation airbags and numerous state-of-the-art safety systems and devices.

### AIRBAGS AND ACTIVE HEADRESTS

The Quattroporte comes equipped with six airbags. Two front airbags, both dual-stage, shield the driver and front passenger in the event of collision, while further protection comes courtesy of side and window airbags. Working in conjunction with the airbags are active headrests on the front seats that automatically move in closer to the occupants' heads to reduce the risk of whiplash injury.

### BRAKES

All versions of the Quattroporte feature powerful Brembo brakes that have been carefully matched to the performance of their engines. To help reduce the car's unsprung mass, they feature dual-cast discs, which combine the strength of cast iron with the lightness of aluminium. As an option, the brake callipers can be specified in black, blue, silver or red.

### MASERATI STABILITY PROGRAMME

The Maserati Stability Programme is an advanced electronic stability control system that reduces torque from the engine and activates the brakes if the vehicle begins to deviate from its normal trajectory or if a skid is detected - all in a few milliseconds.

### TYRE PRESSURE MONITORING SYSTEM

The Tyre Pressure Monitoring System continuously monitors tyre pressures by means of sensors fitted inside the wheel rims. The tyre pressure is shown on the display in the centre of the dashboard, and a warning light and audio alert inform the driver if any tyre pressure drops below the optimal level, or in the event of a puncture.

# SAFETY

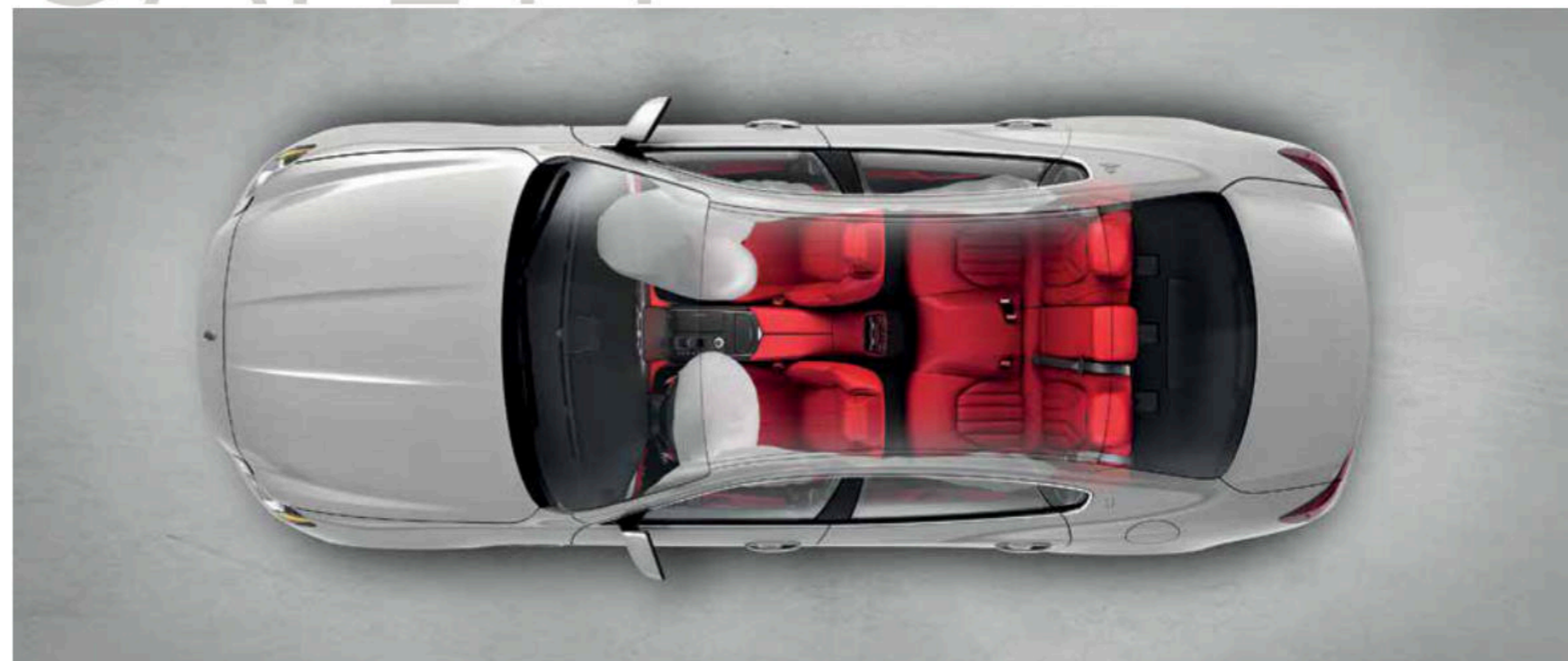

#### BI-XENON HEADLIGHTS AND ADAPTIVE FRONT LIGHTING SYSTEM

The Quattroporte features the very latest Bi-Xenon headlights with Adaptive Front Lighting System. The Adaptive Front Lighting System automatically adjusts the width, depth, and angle of the beam giving maximum light and hence providing maximum safety. This is made possible by monitoring several different parameters, including the steering wheel position, the car's speed, and the way it is being driven. The AFS system comes on automatically when driving in bad weather, on motorways, or in town. In these circumstances, the system adjusts to increase visibility (by up to 70% compared to conventional headlights) and enhance safe driving.

#### AIR QUALITY SENSOR

This feature combines an intelligent sensor and an analysis system that calculates the external pollution levels and prevents polluted air and toxic gases from entering the car's cabin, giving the occupants the cleanest and safest air to breathe. The effective filtering of particulates can significantly improve the health of all onboard.





**FRONT AND REAR PARKING SENSORS AND REVERSING CAMERA**

To assist with manoeuvring in tight spaces, the Quattroporte comes equipped with parking sensors housed in the front and rear bumpers. In addition, a rear-view camera shows what is behind the car on the central console display. Dynamic grid lines illustrate the maximum width of the vehicle and its projected path, based on the steering angle of the front wheels.

**SURROUND VIEW CAMERA**

As a parking aid and to help the driver see into blind zones, the Surround View Camera provides a clear 360° view around the car. Two lateral cameras are housed underneath the door mirrors and, in conjunction with the front and rear cameras, display what is happening in the main display screen.

**ADAPTIVE CRUISE CONTROL WITH STOP & GO**

Adaptive Cruise Control constantly monitors the amount of space between the Quattroporte and the vehicle ahead, maintaining a constant pre-set distance. With the Stop & Go function, the Quattroporte will adjust to the speed of the vehicle in front, until it comes to a complete stop. The system will continue to work if the stop is less than two seconds.



**FORWARD COLLISION WARNING**

The Forward Collision Warning, in combination with the Adaptive Cruise Control, monitors vehicles ahead by means of a camera, and warns the driver if the car's approach could escalate into a rear-end collision. This is linked to the Advanced Brake Assist system, which provides additional braking during an emergency stop. In addition, if the warning does not prompt any action from the driver, the Automated Emergency Braking system automatically applies the brakes to reduce the car's speed, thus potentially avoiding a collision.

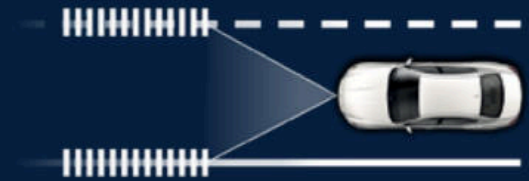

**LANE DEPARTURE WARNING SYSTEM**

Thanks to a camera located in the interior rear-view mirror that monitors the road markings ahead, the Lane Departure Warning System helps the driver keep the vehicle in the chosen lane on motorways and main roads. This reduces lane drift and the possibility of lateral collisions by warning the driver when the vehicle crosses lane markings without signaling.



**BLIND SPOT ALERT AND REAR CROSS PATH**

The Blind Spot Alert continually assesses the space between the Quattroporte and other nearby vehicles. When a side or rear blind spot is encroached upon, for instance by another driver changing lanes, illuminated icons appear in the door mirrors and an audible alert is sounded. The Rear Cross Path function works in a similar way, emitting the same warning when an unseen vehicle is detected approaching from the right or the left as the car reverses out of a parking space.



# INFOTAINMENT



## Controls for your wellbeing. Sounds for your delight.

In the middle of the Quattroporte's dashboard lies the new 8.4" Maserati Touch Control Plus unit (MTC Plus) that provides user-friendly access to the car's many systems and devices. Being both simple and intuitive, and with very few buttons plus a highly responsive interface unit, it has been designed so that the driver is not distracted from the road when using it, and mastering it takes no time at all. There are three ways of operating MTC Plus: by means of the new multi-touchscreen, via the new rotary control in the central console or through voice commands.

The Quattroporte features a powerful Harman Kardon Premium Sound System as standard, with ten speakers and 900 watts of power delivering a clear and perfectly defined audio image to all onboard. Alternatively, the optional Bowers & Wilkins Surround Sound System includes a 16-channel and 1,280-watt amplifier that blends perfectly into the car's interior design, thanks to the meticulous work on the layout of the sound sources. Fifteen speakers have been strategically located in the dashboard, doors and rear shelf to create a completely immersive sound experience, reaching every corner and every ear. Powerful advanced processing ensures that everyone in the car gets a fair hearing. The system incorporates Harman's QuantumLogic™ signal processing and a unique music restoration process called Clari-Fi that instantly scans all types of compressed audio files and intelligently corrects any deficiencies detected.

## DIMENSIONS

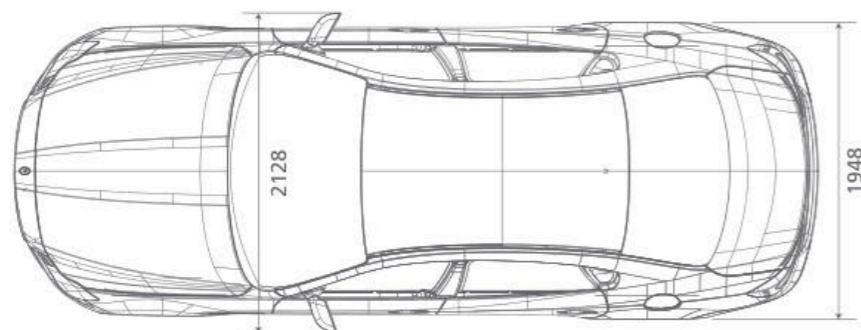
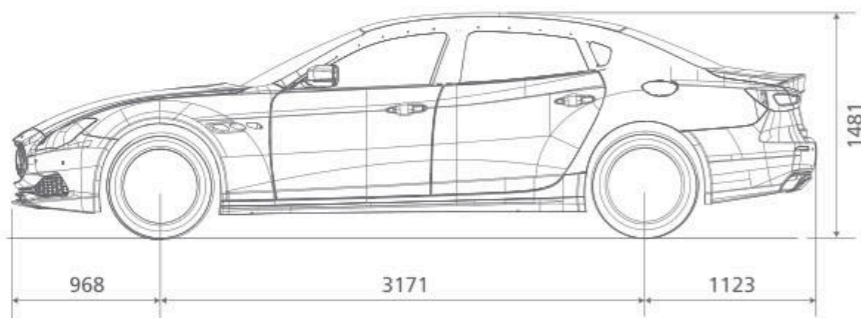
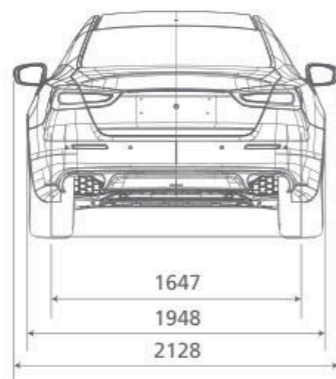
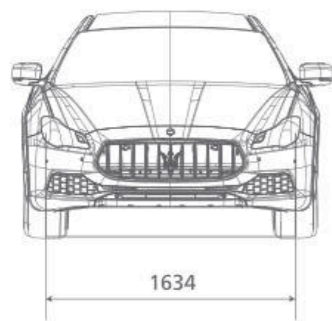

### DIMENSIONS AND WEIGHTS

Length	
Width (with side mirrors)	
Width (without side mirrors)	
Height	
Wheelbase	
Front track	
Rear track	
Front overhang	
Rear overhang	
Turning circle	
Boot capacity	
Fuel tank capacity	
Dry weight	
Vehicle weight	

### ENGINE

Number of cylinders and layout	
Displacement	
Bore	
Stroke	
Transmission	
Compression ratio	
Maximum power output	
Engine speed at maximum power output	
Peak torque	
Engine speed at peak torque	
Overboost torque	
Engine speed at overboost torque	

### PERFORMANCE

Maximum speed	
Acceleration (0 to 100 km/h)	
Stopping distance (100 to 0 km/h)	
Fuel consumption – combined cycle (l/100 km)	
Fuel consumption – urban cycle (l/100 km)	
Fuel consumption – extra urban cycle (l/100 km)	
CO <sub>2</sub> emissions – combined cycle (g/km)	
CO <sub>2</sub> emissions – urban cycle (g/km)	
CO <sub>2</sub> emissions – extra urban cycle (g/km)	
Regulation	

### QUATTROPORTE DIESEL

Length	5262 mm
Width (with side mirrors)	2128 mm
Width (without side mirrors)	1948 mm
Height	1481 mm
Wheelbase	3171 mm
Front track	1634 mm
Rear track	1647 mm
Front overhang	968 mm
Rear overhang	1123 mm
Turning circle	11.8 m
Boot capacity	530 l
Fuel tank capacity	70 l
Dry weight	1815 kg
Vehicle weight	1925 kg

### QUATTROPORTE S

Length	5262 mm
Width (with side mirrors)	2128 mm
Width (without side mirrors)	1948 mm
Height	1481 mm
Wheelbase	3171 mm
Front track	1634 mm
Rear track	1647 mm
Front overhang	968 mm
Rear overhang	1123 mm
Turning circle	11.8 m
Boot capacity	530 l
Fuel tank capacity	80 l
Dry weight	1760 kg
Vehicle weight	1860 kg

### QUATTROPORTE S Q4

Length	5262 mm
Width (with side mirrors)	2128 mm
Width (without side mirrors)	1948 mm
Height	1481 mm
Wheelbase	3171 mm
Front track	1634 mm
Rear track	1647 mm
Front overhang	968 mm
Rear overhang	1123 mm
Turning circle	11.8 m
Boot capacity	530 l
Fuel tank capacity	80 l
Dry weight	1820 kg
Vehicle weight	1920 kg

### QUATTROPORTE GTS

Length	5262 mm
Width (with side mirrors)	2128 mm
Width (without side mirrors)	1948 mm
Height	1481 mm
Wheelbase	3171 mm
Front track	1634 mm
Rear track	1647 mm
Front overhang	968 mm
Rear overhang	1123 mm
Turning circle	11.8 m
Boot capacity	530 l
Fuel tank capacity	80 l
Dry weight	1800 kg
Vehicle weight	1900 kg

### QUATTROPORTE DIESEL

Number of cylinders and layout	V6 60°
Displacement	2987 cm <sup>3</sup>
Bore	83 mm
Stroke	92 mm
Transmission	Automatic, 8 gears
Compression ratio	16.5:1
Maximum power output	275 HP (202 kW)
Engine speed at maximum power output	4000 rpm
Peak torque	600 Nm
Engine speed at peak torque	2000 - 2600 rpm
Overboost torque	—
Engine speed at overboost torque	—

### QUATTROPORTE S

Number of cylinders and layout	V6 60°
Displacement	2979 cm <sup>3</sup>
Bore	86.5 mm
Stroke	84.5 mm
Transmission	Automatic, 8 gears
Compression ratio	9.7:1
Maximum power output	410 HP (302 kW)
Engine speed at maximum power output	5500 rpm
Peak torque	550 Nm
Engine speed at peak torque	1750 - 5000 rpm
Overboost torque	—
Engine speed at overboost torque	—

### QUATTROPORTE S Q4

Number of cylinders and layout	V6 60°
Displacement	2979 cm <sup>3</sup>
Bore	86.5 mm
Stroke	84.5 mm
Transmission	Automatic, 8 gears
Compression ratio	9.7:1
Maximum power output	410 HP (302 kW)
Engine speed at maximum power output	5500 rpm
Peak torque	550 Nm
Engine speed at peak torque	1750 - 5000 rpm
Overboost torque	—
Engine speed at overboost torque	—

### QUATTROPORTE GTS

Number of cylinders and layout	V8 90°
Displacement	3799 cm <sup>3</sup>
Bore	86.5 mm
Stroke	80.8 mm
Transmission	Automatic, 8 gears
Compression ratio	9.5:1
Maximum power output	530 HP (390 kW)
Engine speed at maximum power output	6500 - 6800 rpm
Peak torque	650 Nm
Engine speed at peak torque	2000 - 4000 rpm
Overboost torque	710 Nm
Engine speed at overboost torque	2250 - 3500 rpm

### QUATTROPORTE DIESEL

Maximum speed	252 km/h
Acceleration (0 to 100 km/h)	6.4 s
Stopping distance (100 to 0 km/h)	35.5 m
Fuel consumption – combined cycle (l/100 km)	6.2 (45.6 mpg)
Fuel consumption – urban cycle (l/100 km)	7.9 (35.8 mpg)
Fuel consumption – extra urban cycle (l/100 km)	5.2 (54.3 mpg)
CO <sub>2</sub> emissions – combined cycle (g/km)	163
CO <sub>2</sub> emissions – urban cycle (g/km)	208
CO <sub>2</sub> emissions – extra urban cycle (g/km)	137
Regulation	Euro 6

### QUATTROPORTE S

Maximum speed	286 km/h
Acceleration (0 to 100 km/h)	5.1 s
Stopping distance (100 to 0 km/h)	35.5 m
Fuel consumption – combined cycle (l/100 km)	9.6 (29.4 mpg)
Fuel consumption – urban cycle (l/100 km)	13.8 (20.7 mpg)
Fuel consumption – extra urban cycle (l/100 km)	7.2 (39.2 mpg)
CO <sub>2</sub> emissions – combined cycle (g/km)	223
CO <sub>2</sub> emissions – urban cycle (g/km)	321
CO <sub>2</sub> emissions – extra urban cycle (g/km)	167
Regulation	Euro 6

### QUATTROPORTE S Q4

Maximum speed	286 km/h
Acceleration (0 to 100 km/h)	4.9 s
Stopping distance (100 to 0 km/h)	35.5 m
Fuel consumption – combined cycle (l/100 km)	9.7 (29.1 mpg)
Fuel consumption – urban cycle (l/100 km)	14.2 (19.9 mpg)
Fuel consumption – extra urban cycle (l/100 km)	7.1 (39.8 mpg)
CO <sub>2</sub> emissions – combined cycle (g/km)	226
CO <sub>2</sub> emissions – urban cycle (g/km)	330
CO <sub>2</sub> emissions – extra urban cycle (g/km)	165
Regulation	Euro 6

### QUATTROPORTE GTS

Maximum speed	310 km/h
Acceleration (0 to 100 km/h)	4.7 s
Stopping distance (100 to 0 km/h)	34 m
Fuel consumption – combined cycle (l/100 km)	10.7 (26.4 mpg)
Fuel consumption – urban cycle (l/100 km)	15.6 (18.1 mpg)
Fuel consumption – extra urban cycle (l/100 km)	7.9 (35.7 mpg)
CO <sub>2</sub> emissions – combined cycle (g/km)	250
CO <sub>2</sub> emissions – urban cycle (g/km)	363
CO <sub>2</sub> emissions – extra urban cycle (g/km)	184
Regulation	Euro 6

## The world of Maserati. Its heart races.

### MASTER MASERATI DRIVING COURSES

It is perhaps the ultimate driving experience. Driving exclusive, high-performance cars, having fun and acquiring basic skills similar to those of a professional driver. Through its exclusive Driving Courses, Maserati, which has always prioritised the quality of its cars' handling, places a special emphasis on the correct technique for driving the Brand's cars, with the aim of enabling participants to become as one with their vehicles. 8 different course types which are organized not only in Italy at the Varano de Melegari track but also in China, USA and Sweden.

### MASTER WARM-UP

The Maserati Master Warm-Up offers customers and prospects an initial taste of training in the techniques of racing track driving in high-performance cars, with the support of highly qualified, expert staff. It provides the opportunity of entering the world of Maserati as a privileged guest, at Varano de Melegari, home of the Master Maserati courses since 1998. The ½ day driving course involves a series of dynamic activities, including several on-circuit driving sessions, combined with a car-handling exercise that tests each participant's driving abilities, which can then be perfected in subsequent courses.

### MASTER GT 1 DAY

The one-day Master GT driving course has been designed to improve the participant's personal driving techniques at the wheel of different Maseratis. This intensive training programme comprises a number of exciting and dynamic sessions in high-performance cars, and is run by highly trained, specialist staff whose aim is to improve every delegate's driving skills in an environment that is enjoyable and challenging for all.

### MASTER PREMIUM

An intensive 1, 5-days program that focuses on advanced

GT handling techniques and safe, yet sporty driving. In a sequence of sessions on the circuit, the driver is taught how to control the car in different simulated road conditions (e.g. quick direction changes, controlled skids and braking techniques). The ultimate aim is to use the lessons learned to maximize the enjoyment of driving a high-performance Maserati.

### MASTER HIGH PERFORMANCE

The programme of the Master High Performance includes advanced high-speed driving and technically more complex exercises that build upon the fundamental skills acquired in the earlier Master GT and Master Premium courses. The teaching and structure of this course are adapted to the individual needs of the participants, who can improve their driving proficiency through the analysis of Formula 1-type telemetry data.

### MASTER ITALIAN LIFESTYLE EXPERIENCE

This exclusive, five-star event allows Maserati enthusiasts and their companions to experience the very best that Italy has to offer. Along with a series of Maserati racetrack sessions for the driver, both participants enjoy a programme of first-class activities and excursions in two cities steeped in history and culture: Florence and Parma.

### SNOW MASTER EXPERIENCE

Treacherous yet beautiful, maintaining full control of your car when driving on snow is always a challenging prospect. With the brand new Snow Master Experience, created to give you the unique experience of car control in extreme conditions on snow and ice, you can improve your driving skills and delight in impressive performance of the Maserati cars even in the most extreme situations. An enjoyable intensive-driving course, structured around thrilling and exciting teaching with complete safety guaranteed thanks to the experience and professionalism of the Master

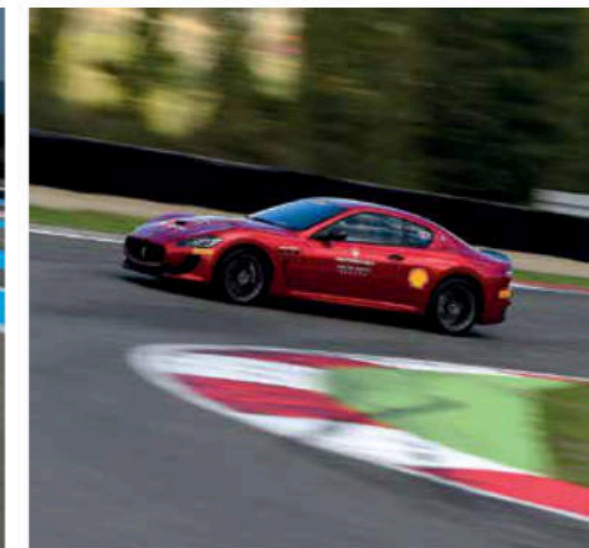

Maserati instructors. This special driving course will be held on beautiful tracks in Lapland or in the Alps.

### MASTER LEVANTE

Master Levante is the specific driving course that combines track driving techniques with the most effective approach to driving on off-road terrains. The training uses the entire Maserati range, focusing in particular on the Levante model, which represents the state-of-the-art in the Sport Utility Vehicle segment. With its amazing performances, it provides the most exciting of all driving experiences, both on track and on unpaved trails and uneven ground. A 1,5 days high-adrenalin driving course with the perfect balance between theory sessions and on-track and off-road driving practice, conceived for full enjoyment of the performances of a car that truly knows no boundaries.

### MASTER MASERATI INCENTIVE

Master Maserati Incentive courses last either half a day or a whole day, and include a series of highly stimulating activities. Aside from the thrilling driving sessions on the

track, there are practice exercises and competitions that foster team spirit — hence they provide the perfect context for corporate incentive events and team-building exercises.

For more information and registration, contact the Master Maserati Secretariat.

Telephone: +39 0525 551138 – Fax: +39 0525 551140

E-mail: [info@mastergt.it](mailto:info@mastergt.it)

[www.maserati.com/MasterMaserati](http://www.maserati.com/MasterMaserati)

**FINANCIAL SERVICES**

Official Maserati dealers will be delighted to provide you with professional guidance on the various payment options available, and create a package tailored to your individual requirements.

**FACTORY TOUR\***

Find out where and how the Maserati legend was born. Maserati offers you the opportunity of discovering its secrets from the inside, through a guided tour of the Modena production plant. Discover how the cars are created, learn their secrets, understand their engineering and really feel part of the Maserati family.

**MASERATI EXPERIENCE\*\***

For those wishing to combine their factory visit with a little more insight into the company's home city of Modena, Maserati has the perfect solution. Lasting one or more days, the Maserati Experience enables you to get to know the world of Maserati first-hand via a guided tour that allows you to discover Modena, its culture, its history and its fine food. You can tailor your Maserati experience to your own personal tastes and interests by combining these with a variety of other activities:

- A visit to the Panini Museum and/or Stanguellini Museum (famous motor museums)
- A guided tour of the town
- A guided tour of a traditional balsamic vinegar manufacturer, with tastings
- A guided tour of a winery, with tastings of local wines
- Cookery school
- A day at the Modena Golf & Country Club
- And much, much more.

**MASERATI COLLECTION**

The Maserati Collection of quality leisurewear, goods and branded merchandise has been specially created for those who share the Maserati passion, and who seek to associate with the illustrious marque. Maserati Collection items are available from all Maserati dealers, and from the Maserati Store at the Maserati showroom in Modena. Alternatively, all the articles in the collection can be purchased online at [www.maseratistore.com](http://www.maseratistore.com) and delivered directly to your home.

**MASERATI CLUB**

Joining the exclusive Maserati Club means sharing thrills and experiences with other Maserati owners, and being invited to take part in special motoring events all over the world. Drivers of cars from every era can enjoy the pleasure of driving their Maseratis in a calendar of events created specially for Maserati Club members. The Maserati Club provides the link between the past, present and future of the company.

**MASERATI GENUINE ACCESSORIES**

Specially conceived to satisfy our Customers' needs, the Maserati Genuine Accessories are a perfect combination of design and functionality. The attention to detail, style and quality of each individual accessory reveal the very essence of the Maserati brand, always searching for the

perfect balance between comfort and performance. The Quattroporte Accessory range offers customers the best in transport solutions, combined with style and design. Developed to fully enjoy the spaciousness and functionality of the car in any situation, the Maserati-branded transport systems include accessories such as the Luggage Compartment Net, Ski and Snowboard Bag and Luggage Compartment Mat. Added to the range are practical and safety accessories, such as the MGT (Maserati Genuine Tyres) Branded Tyres, Car Covers and Luggage Compartment Box. These are just some of the many products available for this car, demands the utmost attention to detail to make every experience on board unique.

**MASERATI CLASSICHE**

Created for enthusiasts and owners of vintage Maserati cars, Maserati Classiche is an organisation dedicated to those who wish to engage with the marque's glorious past. The Maserati Classiche range of products includes items that celebrate the company's history: paintings of glorious events, pictures of classic Maseratis, original reproductions of parts catalogues, owners' handbooks and old brochures, clothing, scale models and much, much more. All the latest items can be found on [www.maserati.com](http://www.maserati.com) in the Maserati – Maserati Classic section. Or for more information, email [maserati.classiche@maserati.com](mailto:maserati.classiche@maserati.com)

\*Factory tours are only arranged by appointment and can be booked through official Maserati dealers worldwide

\*\*For more information, please email us at: [maseratiexperience@maserati.com](mailto:maseratiexperience@maserati.com)

## World of Maserati.

### EUROPE

Austria  
Belgium  
Bulgaria  
Cyprus  
Czech Republic  
Denmark  
Estonia  
France & Monaco  
Germany  
Greece  
Hungary  
Israel  
Italy  
Lithuania  
Luxembourg  
Netherlands  
Norway  
Poland  
Portugal  
Romania  
Russia  
Slovenia  
Spain  
Sweden  
Switzerland  
Turkey  
Ukraine  
United Kingdom

### AFRICA & MIDDLE EAST

Bahrain  
Egypt  
Jordan  
Kuwait  
Lebanon  
Morocco  
Oman  
Qatar  
Saudi Arabia  
South Africa  
United Arab Emirates



### ASIA/OCEANIA

Australia  
Azerbaijan  
China  
Hong Kong  
India  
Indonesia  
Japan  
Kazakhstan  
Malaysia  
New Zealand  
Philippines  
Singapore  
South Korea  
Taiwan  
Thailand  
Vietnam



### NORTH AMERICA

USA  
Canada

### CENTRAL/SOUTH AMERICA

Argentina  
Brazil  
Chile  
Colombia  
Costa Rica  
Dominican Republic  
Guatemala  
Mexico  
Panama  
Puerto Rico  
Uruguay

MASERATI CONTACT CENTRE - [info@maserati.com](mailto:info@maserati.com)





The illustrations and texts contained in this brochure are based on the information available at the time of production. Some models, equipment and accessories may not be available or may only become available after the car's launch on the market. Maserati reserves the right to modify colours, designs and technical features at any time and without pre-notice. Official Maserati Dealers will be glad to provide further details and updates in this regard. Stay in touch with Maserati by visiting [www.maserati.com](http://www.maserati.com)



[WWW.MASERATI.COM](http://WWW.MASERATI.COM)

MASERATI SPA · VIALE CIRO MENOTTI, 322 · 41121 MODENA · ITALY