

AMG GT S

2016



AMG
DRIVING PERFORMANCE

 Mercedes-Benz



Before engaging in any racing or competitive driving event, carefully review the applicable provisions in your New Vehicle Limited Warranty booklet.

HANDCRAFTED BY RACERS.

Earning a name in motorsports requires more than attaching your logo to a racecar. For nearly half a century, Mercedes-AMG has been dreaming, developing, crafting—and most importantly, racing—racecars. The most successful team in DTM history, AMG has also earned a dozen GT3 championships and two Formula 1® titles. The high-performance AMG automobiles that you can relish driving home every night are developed by the same team of passionate professionals who bring trophies home from the track. For 2016, there's a new sports car developed from road to roof by Mercedes-AMG.

Fifty engineers—including AMG race drivers—flogged, flailed and fine-tuned 100 prototypes up 11,000-ft Utah mountains, at -22°F Swedish sunrises, through 122°F Death Valley heat, and over 21,000 miles on the Nürburgring Nordschleife alone. Introducing the AMG GT S: a pure sports car in perfect balance—created and crafted to send your heart racing, in every sense of the phrase.

PURELY EMOTIONAL.



A 509-lb sculpture of aluminum, magnesium and a hint of steel shapes the future of a performance legacy. The long hood and strong shoulders reveal the natural balance of the powertrain, and of its performance skill set: Lightness, with each of its 503 hp carrying just 7.3 lbs. Aerodynamics, with every intake, outlet, spoiler and diffuser feeding air in, drawing heat away, generating downforce, and luring the eye. Brilliance, with the superlative visibility and visual signature of full-LED lighting. And distinction, with gloss or matte paintwork, three styling packages, and six wheel choices, so each AMG GT S can be the pure reflection of its driver.



AMG GT S shown with optional *designo* Magno Iridium Silver paint, cross-spoke forged wheels in Black, and AMG Night Styling Package.

ONE MAN, ONE ENGINE.



The 503-hp biturbo V-8 of the AMG GT S is built using the same principles as the engines powering AMG's Formula 1[®], DTM and GT3 racecars. Each engine is hand-built by its own master craftsman, from the inspection of each part to final testing. In a sports-car first, AMG engineers have developed a completely new engine teaming dry-sump lubrication with a "hot inside V" turbo setup. With no oil pan, the V-8 is mounted 2.2" lower and further back, improving front/rear balance and lowering the car's center of gravity. The two intercooled turbos nest between the cylinder banks—a compact design that eradicates turbo lag while enhancing efficiency.

AMG GT S shown at left with optional Brilliant Blue metallic paint, cross-spoke forged wheels in Titanium, and AMG Carbon-Ceramic braking system. AMG GT S shown below with Mars Red paint and optional AMG Exterior Carbon Fiber Package. Please see endnotes on back cover.



High-pressure dry-sump lubrication

can circulate all 9.5 quarts of motor oil in the external reservoir through the engine at a rate of 4.4 quarts/second.

In addition to reducing the overall engine height to allow its low, front-mid mounting, the system's suction pump and pressure pump assure consistent oil flow even under the high g-forces of hard corners.

Cooling of the engine oil, transmission fluid and differential gear oil is managed by a separate circuit for each system.

Twin, quick-spooling turbochargers

can achieve 186,000 rpm and 16 psi of boost. Their placement in the "hot V" between the cylinder banks shortens their pumping paths, cutting pressure loss and lag.

Powerful twin intercoolers feature a dedicated cooling system that circulates up to 110 gallons/minute. They can chill the compressed charge from 280° F at the turbos' exit, to within 45° of the outside temperature as it reaches the combustion chambers—maximizing its air density.

AMG-patented NANOSLIDE® technology

plasma-sprays the cylinder walls using an electrical arc—a technology transferred from AMG's F1 racing engines. It creates a mirror-smooth, low-friction finish that's twice as hard as steel. The cylinder bores are honed with a dummy head bolted in place, for greater dimensional accuracy when the forged pistons and low-friction rings are installed. The V-8 delivers higher performance, efficiency and endurance with a best-in-class 461-lb dry weight.

Third-generation Direct Injection

pressurizes gasoline to 2,900 psi. Within milliseconds, piezo injectors can atomize the fuel in an ultra-precise pattern that's optimized in real time. Each spark plug can

rapid-fire four times in a millisecond, for the strongest, cleanest combustion. The AMG Dynamic Performance Exhaust can actively bypass its rear muffler, unleashing the compact 4.0-liter V-8's unmistakable symphony of snarling revs, open-throttle crescendos, and crackling deceleration.



POWER OF BALANCE.

The dynamically ideal 47/53 front/rear weight distribution of the AMG GT S comes from its front-mid-engine/rear-transaxle layout. Weighing less than 9 lbs, a carbon-fiber driveshaft transfers the biturbo V-8's enormous power from within a highly rigid aluminum torque tube. The transaxle unites the 7-speed dual-clutch gearbox and new electronic limited-slip differential in one housing. Every chassis element helps optimize weight, balance, agility and feedback – from the forged aluminum double-wishbone suspension to brake calipers oriented toward the car's center.



A 47/53 front/rear weight distribution

is the ideal setup for a car in motion.

At launch, it helps the 295/30R20 rear tires' turn grip into acceleration. Along with the low center of gravity, it reduces inertia when changing direction. Braking into corners—when the weight naturally shifts forward—it minimizes understeer.

And powering out of a corner, it helps you get back up to speed more quickly.

Balanced performance is the direct result of the car's ideal balance.

Lowering weight and elevating rigidity

are the simultaneous goals evident from the body structure to the running gear.

The body is 90% aluminum—strategically cast, stamped and extruded to combine extremely high longitudinal and torsional rigidity with a class-benchmark weight

of just 509 lb for the body-in-white. To minimize inertia ahead of the front axle, the upper radiator crossmember is made from even lighter, stronger magnesium.

Racing-bred AMG Adaptive Suspension

uses forged aluminum double wishbones and hub carriers at all four wheels, raising rigidity while reducing unsprung weight.

Parallel upper and lower arms, plus coil-over shocks—hub-mounted at the rear—sharpen precision. Even at the limits, they help keep handling direct, agile and highly predictable. Comfort, Sport and Sport+ modes firm up the electronically controlled shocks at progressively lower thresholds of motion, lateral g-forces and speed.

The 7-speed AMG SPEEDSHIFT® DCT

gearbox offers five modes. In the Sport, Sport+ or Race mode, its dual clutches can shift in less than 100 milliseconds.

Along with direct 7-4 and 5-2 downshifts, the time spent off-throttle is minimized.

A new electronically controlled limited-slip differential varies its locking factor to road friction, lateral acceleration and steering angle. Its greater sensitivity, precision and reaction time versus a mechanical lock help raise cornering grip and speed.²



CHOICE OF
FREEDOM.



The union of values inherent in the name Mercedes-AMG is perhaps most evident where the AMG GT S meets its driver. Technology and craftsmanship lead to confidence and control. The winglike dash and wide, V-shaped console are the epitome of man-machine interaction. A vivid 8.4" central screen responds to the touchpad controller on the console. A color display within the gauge cluster can show a variety of performance readouts, including digital speed,

gear selection, a 3-color upshift indicator, and a RACETIMER lap timer. AMG Performance seats power-conform to your physique, for optimal support in a hairpin corner or heavy traffic. The steering wheel—hand-stitched in Nappa leather, DINAMICA microsuede, or a combination of both—lures your fingertips directly to the aluminum shift paddles. The optional Black Diamond console finish is created from a plasma suspension of precious metals, vapor-deposited

at nearly 1,800°F. The console, aircraft-style dash vents, and the rear-cabin crossbar can also be trimmed in silver chrome, gloss or matte carbon fiber, or silver fiberglass. The spacious cargo area welcomes two golf bags, while you can fill the cockpit with 640 watts of lush surround sound. Burmester,[®] Germany's renowned handcrafter of high-end home audio, has created a standard 10-speaker, 10-channel system that's rich in sound yet light in weight.

HEART-SOUL COORDINATION.



Born to perform. The motorsports know-how that's engineered into every component of the AMG biturbo V-8 gives the car its racing heart. A plaque on the engine cover bears the signature of its builder. The two hands that lovingly craft each engine do more than bring it to life. They also give each AMG GT S its undeniable soul.

Instant connection. The AMG Performance seats are not merely racing-inspired, they're track-ready. Deep bolsters for the torso and thighs are power-adjustable. Along with their integrated head restraints, the seats support the driver and passenger during highly dynamic driving—from winding roads to racing circuits.





Full control. Configured to evoke the V-8 engine, the console's eight controls invite fine-tuning of the car's performance at any time. Individual pushbuttons offer a multitude of modes for the suspension, shifting, exhaust, and ECO Start/Stop. The touchpad COMAND® system unifies the audio, navigation and Cloud-based apps.³



Five drive modes. A twist of the AMG DYNAMIC SELECT knob lets you choose any of four driving setups, or create your own Individual program à la carte. Each of the Comfort, Sport, Sport+ and Race modes adapts the throttle response, shift programming, 3-stage ESP®, suspension, steering, exhaust, and ECO Start/Stop system.

AMG DYNAMIC PLUS Package.

Further extending the on-track capabilities of the AMG GT S is a suite of engineering enhancements. Tauter damping, increased negative camber and reprofiled steering deliver more direct response via an AMG Performance steering wheel hand-stitched in grippy DINAMICA microsuede. Crisp yellow gauge graphics hint at the engine's widened power band—extended to deliver maximum horsepower from 6,000 to 6,500 rpm. Revised mapping of the chassis and powertrain controls sharpens their response in Manual and Race modes. And the package's technological centerpiece is its active engine and transmission mounts. Innovative magnetorheological fluid can stiffen the mounts in 0.001 sec when electrical current is applied. By individually varying their rigidity, the mounts help to increase steering precision, stability and driver feedback during rapid revs, high cornering forces or hard braking. And since the fluid reverts to more supple isolation when the current is no longer applied, they can provide smooth comfort in everyday driving.

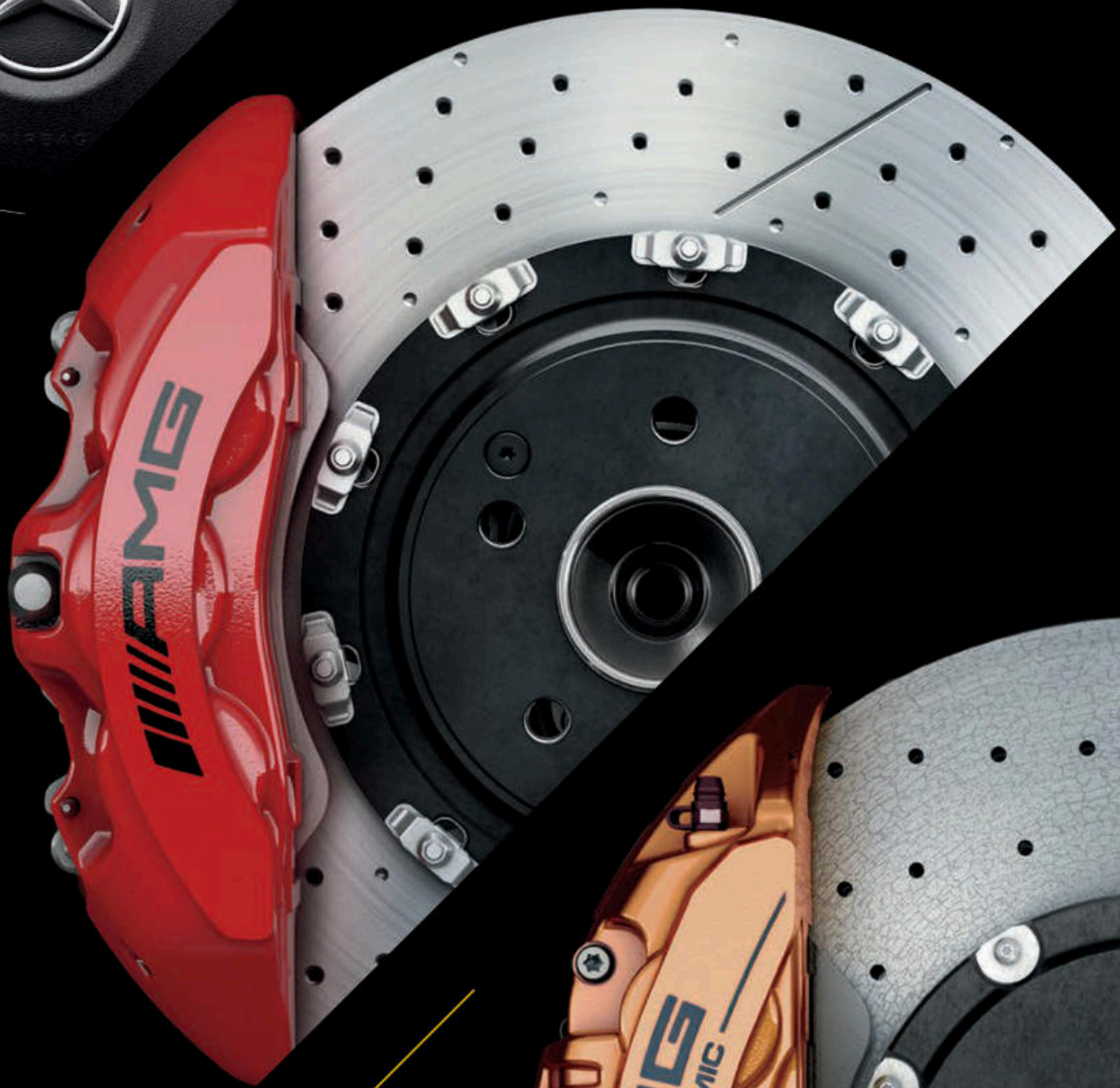

AMG High-performance Braking System. Compound front brake discs bolt perforated, ventilated and slotted 15.4" steel friction rings to lightweight aluminum centers. Red-painted fixed 6-piston front calipers apply the pads with powerful, evenly distributed force. Vented and perforated 14.2" rear discs with sizable floating calipers optimize performance and unsprung weight.⁴

AMG Carbon-Ceramic Braking System. Bronze calipers identify the ultimate performance of optional carbon-fiber-reinforced ceramic brake discs. Harder, longer-wearing, and extremely resistant to heat-induced fade, they're ideally suited to the demands of track driving. And even with larger 15.8" front discs, the overall hardware is 40% lighter—reducing unsprung mass for enhanced handling response and steering feel.⁵



CRAFTED.

Complementing the exquisite workmanship of each AMG GT S is an equally extraordinary degree of personalization. Gloss or matte paint, six wheel styles and three exterior styling packages can be mixed with a spectrum of upholstery options and ways to detail the console, rear crossbar, door sills and seat belts. There are more than a million possibilities to create an AMG GT S that's crafted just for you.

Paintwork. Advanced nanotechnology paint finishes help resist scratches and environmental damage by infusing the clearcoat with tiny ceramic particles. The palette includes deep gloss colors as well as ultramodern matte finishes.

Exterior styling packages. Numerous body details, from the front air-dam splitter to the side mirror covers and rear diffuser, can be detailed in carbon fiber, gloss black, or silver chrome.

Upholstery. Smooth and supple Nappa leather is hand-fitted to the seats and armrests. The AMG Affalterbach crest is embossed into the console lid. Also available is Exclusive Nappa leather, which further envelops the dash, doors and console. DINAMICA microsuede can also trim the seat inserts, lower dash and ceiling, set off by contrasting topstitching in any of three colors.

Cockpit trim. As many as five choices of trim can detail the center console and rear crossbar—both matching or each in its own complementary style.

Cabin details. Seat belts are offered in black, red or silver. Door sills feature stainless steel trim, or can be outfitted in carbon fiber or with the welcoming soft glow of illuminated AMG logos.

Paintwork

- Black
- Mars Red
- Magnetite Black metallic
- Iridium Silver metallic
- Brilliant Blue metallic
- designo Selenite Grey metallic
- AMG Solarbeam Yellow metallic
- designo Diamond White metallic
- designo Cardinal Red metallic
- designo Magno Selenite Grey (matte)
- designo Magno Iridium Silver (matte)

Upholstery

- Black Nappa leather or Exclusive Nappa leather
- Auburn Brown Nappa leather or Exclusive Nappa leather
- Porcelain/Black Exclusive Nappa leather
- Red Pepper/Black Nappa leather or Exclusive Nappa leather
- Silver Pearl/Black Nappa leather or Exclusive Nappa leather
- Black Exclusive Nappa leather/DINAMICA with Yellow stitching
- Black Exclusive Nappa leather/DINAMICA with Silver accents and stitching
- Black Exclusive Nappa leather/DINAMICA with Red accents and stitching
- Saddle Brown Exclusive Nappa leather with diamond stitching

Interior trim

- AMG Silver Chrome
- AMG Black Diamond
- AMG Gloss Carbon Fiber
- AMG Matte Carbon Fiber
- AMG Silver Chromeless



19" front/20" rear AMG forged 10-spoke, Titanium



19" front/20" rear AMG split 5-spoke, Titanium



19" front/20" rear AMG forged cross-spoke, Titanium



19" front/20" rear AMG twin 5-spoke, Titanium (standard)



19" front/20" rear AMG split 5-spoke, Black



19" front/20" rear AMG forged cross-spoke, Black

Option Packages

AMG DYNAMIC PLUS Package

- Dynamic engine and transmission mounts
- Widened power band (peak horsepower @ 6,000–6,500 rpm)
- Dynamically enhanced handling features (firmer damping, reprofiled steering, increased negative front-wheel camber)
- AMG Performance steering wheel in full DINAMICA
- Yellow instrument graphics

Lane Tracking Package

- Blind Spot Assist¹
- Lane Keeping Assist⁷

Exclusive Interior Package

- Included with Exclusive Nappa leather or Exclusive Nappa leather/DINAMICA upholstery*
- Black DINAMICA ceiling and pillar trim
 - Extended ambient cabin lighting

Individual Options

- AMG[®] Carbon-Ceramic braking system⁵
- DISTRONIC PLUS⁸
- Carbon fiber engine compartment cover
- Panorama roof
- Rear badge deletion
- Indoor car cover
- Burmester[®] High-End Surround Sound System, with 11 speakers and 1,000 watts total power

- AMG illuminated door sill trim
- AMG carbon fiber door sill trim

- 19" front/20" rear AMG split 5-spoke wheels, Titanium¹
- 19" front/20" rear AMG split 5-spoke wheels, Black¹
- 19" front/20" rear AMG 10-spoke forged wheels, Titanium¹
- 19" front/20" rear AMG cross-spoke forged wheels, Titanium¹
- 19" front/20" rear AMG cross-spoke forged wheels, Black¹

- Metallic paint
- *designo* metallic paint
- *designo* Magno paint (matte finish)

Exterior Styling Packages

AMG Exterior Carbon Fiber Package

Not available with Night Styling or Silver Chrome Package

- Carbon fiber front air-dam splitter, front fender-vent fins, side mirrors and rear apron insert
- Gloss Black grille crosswing surround and side window trim

AMG Night Styling Package

Not available with Exterior Carbon Fiber or Silver Chrome Package

- Gloss Black front air-dam splitter, grille crosswing surround, front fender-vent fins, side mirrors, side window trim and rear apron insert
- Black chrome tailpipes

AMG Silver Chrome Package

Not available with Exterior Carbon Fiber or Night Styling Package

- Silver Chrome front air-dam splitter
- Diamond-block grille with individually chrome-tipped pins
- Stainless steel side window trim

Interior Styling Options

Upholstery

- Nappa leather *Standard*
- Exclusive Nappa leather *Includes Exclusive Interior Package*
- Exclusive Nappa leather/DINAMICA with contrasting stitching *Includes Exclusive Interior Package*

Interior trim

- Silver Chrome *Standard*
- AMG Black Diamond
- AMG Gloss Carbon Fiber Exclusive
- AMG Matte Carbon Fiber Exclusive
- AMG Silver Fiberglass Exclusive

Rear-cabin crossbar trim

- Silver Chrome *Standard*
- Gloss Carbon Fiber
- Matte Carbon Fiber
- Silver Fiberglass

Seat belts

- Black *Standard*
- Silver
- Red

Steering wheel

- Nappa leather with DINAMICA side grips *Standard*
- Full Nappa leather *No-charge option available only with Nappa or Exclusive Nappa leather upholstery*
- Full DINAMICA *Included with Exclusive Nappa leather/DINAMICA upholstery or AMG DYNAMIC PLUS Package*

Specifications

Layout	Front-mid engine/rear transaxle with carbon fiber driveshaft in torque tube	Transmission	7-speed AMG SPEEDSHIFT [®] DCT dual-clutch with shift paddles
Engine type	Handcrafted AMG biturbo V-8 with Direct Injection and dry-sump lubrication	Drive configuration	Rear-wheel drive
Displacement	4.0 liters (3,982 cc)	Brakes	Ventilated and perforated 4-wheel disc, 15.4" front – 14.2" rear
Power	503 hp @ 6,250 rpm	Suspension	AMG Adaptive Suspension with 3-mode electronically controlled damping
Torque	479 lb-ft @ 1,750–4,750 rpm	Steering	Rack-and-pinion with hydraulic power assist
Acceleration, 0–60 mph ⁹	3.7 sec	Turning circle	37.7 ft, curb to curb
Top track speed ¹⁰	193 mph (electronically limited)	Fuel capacity	19.8 gallons
Wheels, front–rear ¹	AMG twin 5-spoke, 9.0x19" – 11.0x20"	Cargo capacity ¹¹	12.3 cu ft, with room for two full-size golf bags
Tires, front–rear ¹	265/35ZR19 – 295/30ZR20, high-performance	Curb weight	3,695 lbs

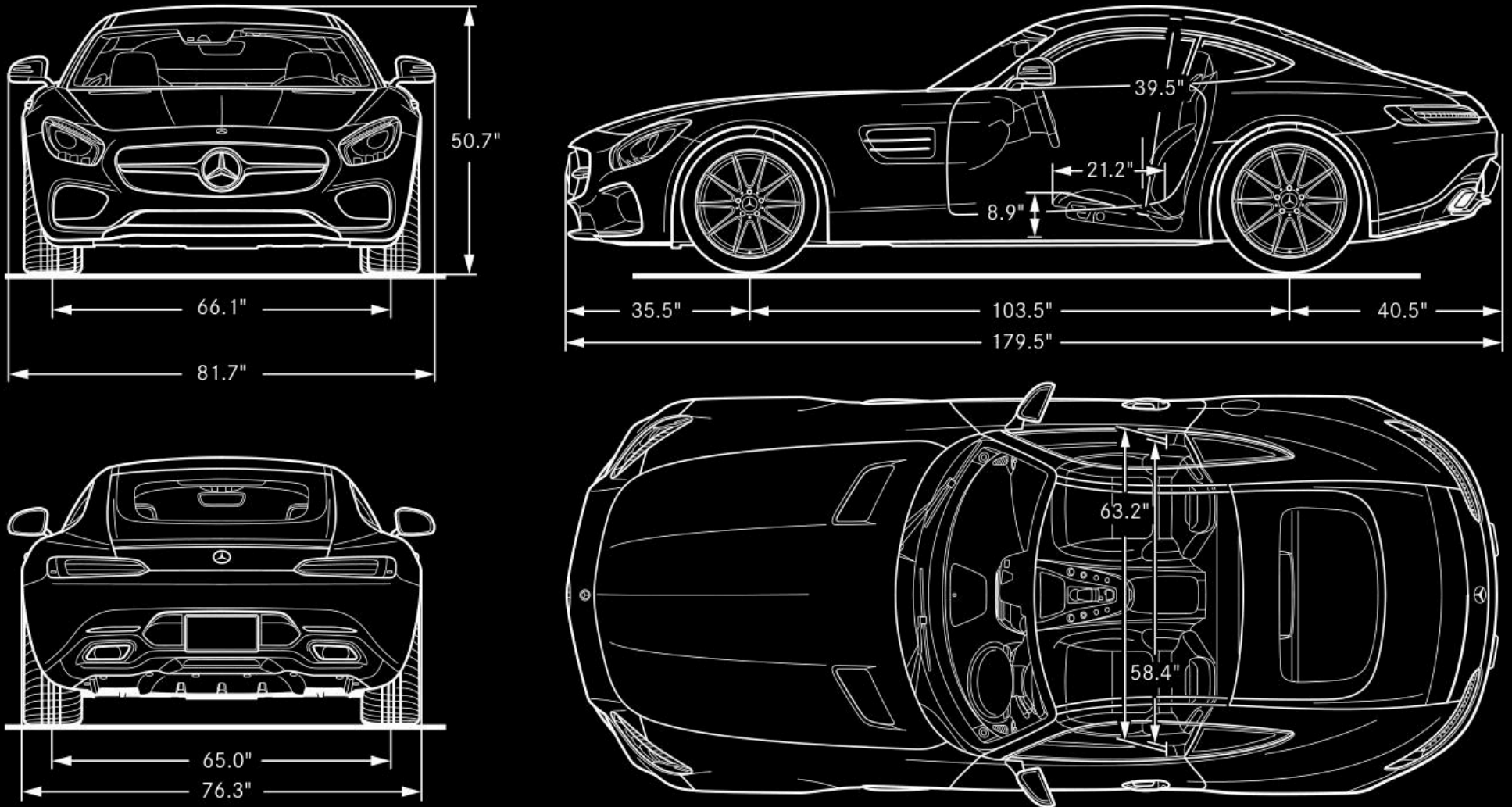

1 Lower aspect ratio tires and accompanying wheels provide substantially increased treadwear, increased tire noise and reduced ride comfort. Serious wheel and tire damage may occur if the vehicle is operated on rough or damaged road surfaces or upon encountering road debris or obstacles. These tires are not designed for use on snow and ice. Winter tires mounted on appropriately sized and approved wheels are recommended for driving in those conditions. Vehicle is provided with TIREFIT sealant and a portable air pump in lieu of a spare tire.

2 No system, regardless of how advanced, can overcome the laws of physics or correct careless driving. Please always wear your seat belt. Performance is limited by available traction, which snow, ice and other conditions can affect. Always drive carefully, consistent with conditions. Best performance in snow is obtained with winter tires.

3 All Mercedes-Benz mbrace[®] services operate only where cellular and Global Positioning System satellite signals are available, which are provided by third parties and not within the control of Mercedes-Benz USA, LLC. An mbrace Package Trial period is offered on new, Certified Pre-Owned and pre-owned sales and leases at an authorized Mercedes-Benz dealer. Subscriber Agreement is required for service to be active. Some services are only available on select vehicles. Your PIN is required in order to use certain services. Some services may be limited or restricted in some areas. Apps may be introduced and updated at varying dates, and may also require a vehicle software update. Driver is responsible for complying with traffic and other laws. See your dealer or MBUSA.com/mbrace for details, including a list of compatible smartphones. Internet-based features require an active subscription to mbrace Mercedes-Benz Apps Package. Connection may be limited by cellular signal.

4 Braking effectiveness also depends on proper brake maintenance, and tire and road conditions.

5 The carbon-ceramic brakes are designed expressly for high-performance braking. It is a characteristic of their

materials and design that brake noise/squeal may result, along with differing brake pedal feel at lower brake temperatures compared to higher operating temperatures.

6 Blind Spot Assist may not be sufficient to avoid all accidents involving vehicles in your blind spot and does not estimate the speed of approaching vehicles. It must not be used as a sole substitute for driver awareness and checking of surrounding traffic conditions. Blind Spot Assist operates at speeds above approximately 20 mph.

7 Driving while drowsy or distracted is dangerous and must be avoided. Lane Keeping Assist may be insufficient to alert a fatigued or distracted driver of lane drift and cannot be relied on to avoid an accident or serious injury. Lane Keeping Assist operates at speeds above approximately 37 mph.

8 DISTRONIC PLUS[®] is no substitute for active driving involvement. It does not adapt cruising speed in response to stationary objects, nor does it predict the curvature and lane layout of the road ahead or the movement of vehicles ahead. It is the driver's responsibility at all times to be attentive to traffic and road conditions, and to provide the steering, braking and other driving inputs necessary to retain control of the vehicle. Drivers are cautioned not to wait for the DISTRONIC Proximity Warning System before braking, as that may not afford sufficient time and distance to brake safely.

9 Stated rates of acceleration are estimated based upon manufacturer's track results and may vary depending on model, environmental and road surface conditions, driving style, elevation and vehicle load.

10 Always obey local speed and traffic laws.

11 Unsecured cargo can become hazardous in a collision. Always secure cargo and raise the standard vertical net.

©2015 Mercedes-Benz USA, LLC
 One Mercedes Drive, Montvale, NJ 07645 • 1-800-FOR-MERCEDES • MBUSA.com
 Marketing Communications. All illustrations and specifications contained in this brochure are based on the latest product information available at the time of publication. Mercedes-Benz reserves the right to make changes at any time, without notice, to colors, materials, equipment, specifications and models. Any variations in colors shown are due to reproduction variations of the printing process. Illustrations may include test situations. Some vehicles may be shown with non-U.S. equipment. Some vehicles are shown with optional equipment. Burmester is a registered trademark of Burmester Audiosysteme GmbH, Berlin, Germany.

