

The New Generation of
OLDSMOBILE



1

9

8

9

TROPÉO • TORONADO • TOURING SEDAN • NINETY EIGHT • EIGHTY EIGHT • CUSTOM CRUISER



Deville Coupe

Deville Sedan



Ultimate Touring Sedan

Ultimate Design



Eighty Eight

Ultimate Design

This is the new generation of Oldsmobile.

Today, teamwork and technology are coming together at Oldsmobile. A reawakening to the excellence of our past and the potential of our future. The result is a bold step ahead. The best of what driving used to be, combined with a vision of what driving is going to be.

This is the New Generation of Oldsmobile.

There are new cars. Then there are new expressions of automotive style and engineering excellence. The latter is what today's drivers should expect, what Oldsmobile buyers have come to expect and what committed Oldsmobile people have once again produced. Automobiles designed and built to stand toe-to-toe with the finest cars the world has to offer.

If there is one car company in America capable of the task of innovating while preserving traditions of quality, solid design and lasting value ... it is Oldsmobile. After all, as long as there have been automobiles, Oldsmobile has been the car company where automotive inspiration is transformed into cars that are right for the times, satisfying to own and drive and a step up from the ordinary in design and execution.

In a new generation of evolving life styles and demands for new measures of excellence, we present

transportation choices that exceed expectations.

We present the 1989 Oldsmobiles ... an impressive balance of style, elegant contemporary design and deeply satisfying performance. Automobiles so different from their predecessors of only a few short years ago that they truly represent the New Generation of Oldsmobile. But nevertheless, Oldsmobiles which embody the spirit, quality, and enduring value that have become the hallmark of a company that reaches back nearly five generations. Founded 91 years ago, the goal was "to build one carriage in as nearly perfect a manner as possible."

The precept was to be a step ahead of the industry. True then. True now. In the New Generation of Oldsmobile.

It's the looks that grab you first.

The new generation Oldsmobiles are stunning. But there's more to their beauty than elegant lines and the tasteful blending of metal, glass, and space-age materials. There's a sense of proportion and purpose that goes beyond mere style.

The same sweep of fender that pleases the eye also guides the wind, to minimize turbulence and increase aerodynamic efficiency.

The advanced metals that form smoothly fitting body panels also resist corrosion and weathering.

Every new generation Oldsmobile is made to look good not just today, but through years of driving.

Technology teams with the human mind.

In the studios where ideas first take form and substance, computer-aided

design combines with the experience and artistry of Oldsmobile designers.

With each component "drawn" and stored in computer memory, hundreds of variations for each component can be analyzed for fit and function. Long before the first proto-type is built, the design for every door handle, engine mount and bumper bracket is tested and retested through computer simulation to be sure it is good enough to carry the Oldsmobile name.

Computer consistency builds better cars.

Throughout the assembly process, computer-controlled robots apply thousands of welds and seals with astonishing precision.

A computerized inspection system probes and verifies critical underbody points for accuracy. Laser inspection devices precisely measure all body openings, and robotic scanners check for dimensional accuracy within thousandths of an inch.

Car builders who care.

With all that technology at work, it is still the dedication and skill of our people that make the difference.

In the final analysis, it is they who establish and maintain the standards for excellence that set this new generation of Oldsmobiles apart from the crowd.

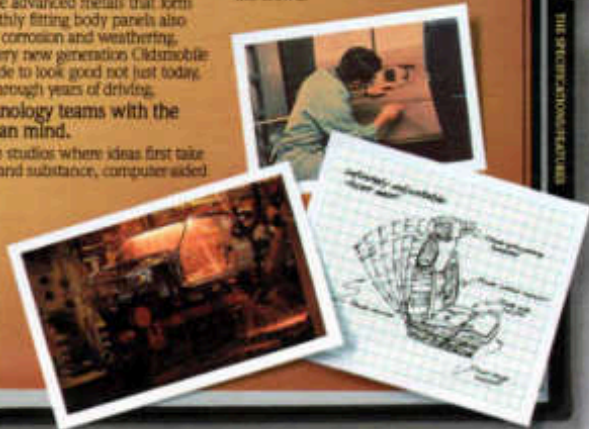

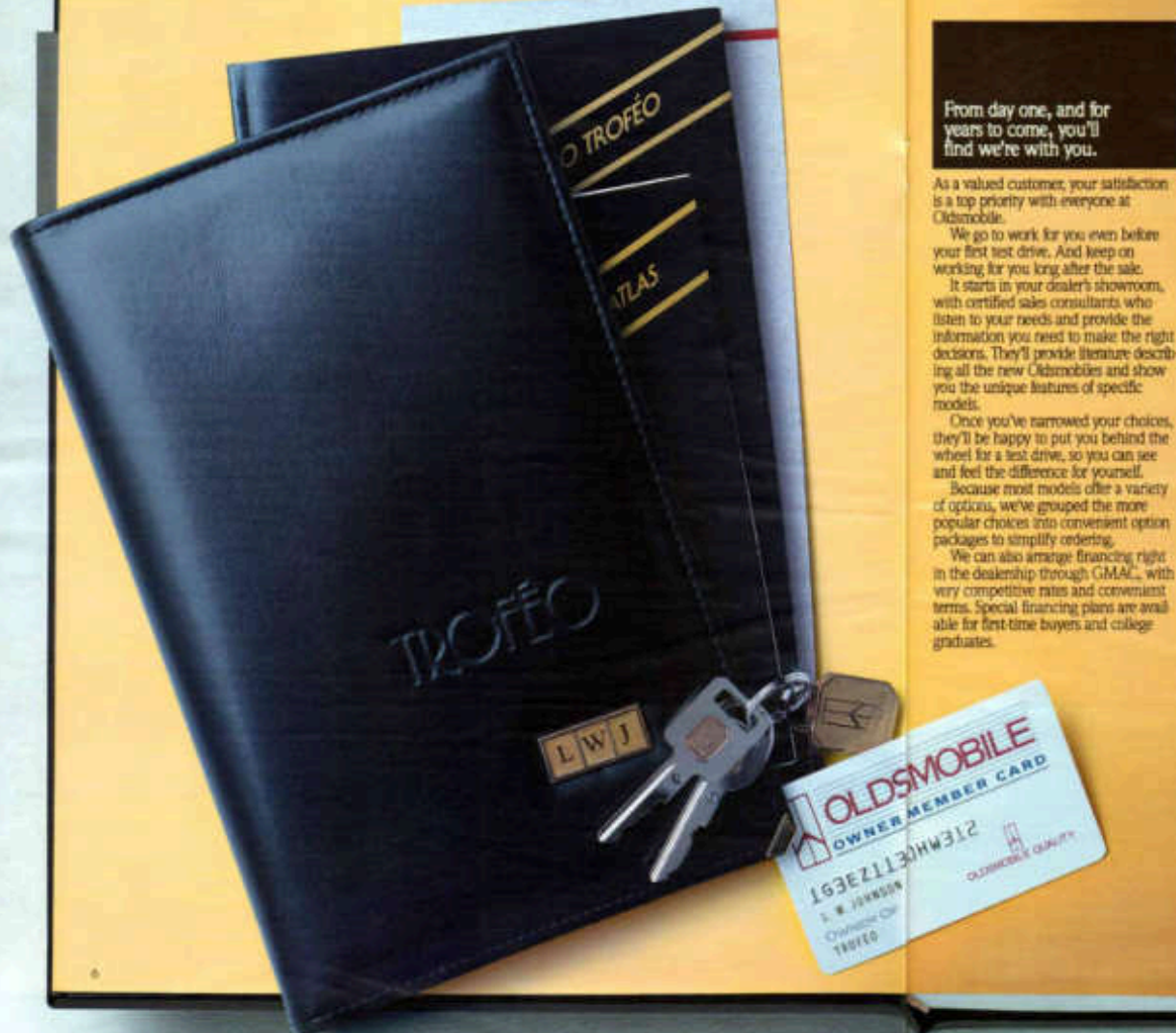

From day one, and for years to come, you'll find we're with you.

As a valued customer, your satisfaction is a top priority with everyone at Oldsmobile.

We go to work for you even before your first test drive. And keep on working for you long after the sale.

It starts in your dealer's showroom, with certified sales consultants who listen to your needs and provide the information you need to make the right decisions. They'll provide literature describing all the new Oldsmobiles and show you the unique features of specific models.

Once you've narrowed your choices, they'll be happy to put you behind the wheel for a test drive, so you can see and feel the difference for yourself.

Because most models offer a variety of options, we've grouped the more popular choices into convenient option packages to simplify ordering.

We can also arrange financing right in the dealership through GMAC, with very competitive rates and convenient terms. Special financing plans are available for first-time buyers and college graduates.

You might also want to consider GMAC leasing. Ask about the low monthly payments available through The Oldsmobile Alternative leasing program.

In most cases, your dealer will have just the car you're looking for in stock and ready to be prepared for delivery. Before it's delivered to you, it will be carefully inspected against a detailed checklist to make sure everything is as it should be.

To get you started off right, your new Oldsmobile will be delivered with a full tank of gas, a special key ring, which can be dropped into any mailbox and returned to you if you lose your keys, and an attractive portfolio including a comprehensive owner's manual, a maintenance schedule, and a copy of your tire warranty.

I think you'll be just as pleased with our service after your purchase. It starts with your dealer's service department. It's the proper place to come for warranty work, and there's no better place for regular maintenance. Stop in and look around. You'll see well-equipped facilities and trained technicians, ready to keep your Oldsmobile performing as it should.

You'll hear from us regularly in the months and years to come, as part of our Owner Communications Program. Soon after the purchase, you'll receive a set of emergency keys in a wallet-sized card, just in case you find yourself locked out of the car. They'll be accompanied by a survey asking about your experience with your dealer, to help us better serve our customers.

Next, we'll send you an Oldsmobile owner member card entitling you to discounts on car rentals and resort condominiums, and other benefits.

At the one year anniversary of ownership, you'll receive a survey inquiring about your satisfaction with Oldsmobile. Your response will help us pinpoint new ways to improve our service to you and other Oldsmobile owners.

Future mailings will include regular maintenance reminders and a news letter with driving and safety tips, information about new products and technology, and other articles of interest to Oldsmobile owners.

We want to keep in touch because we recognize that your car is a very personal possession that requires ongoing contact between Oldsmobile and you, our customers.

With that in mind, I join with all of the people of Oldsmobile in inviting you to read about, test drive and purchase a new Oldsmobile. I promise you not only a car of the highest quality, but our continuing efforts to make your Oldsmobile experience a most rewarding one.

Sincerely,

William W. Lane
Vice President,
General Motors Corporation
General Manager, Oldsmobile Division

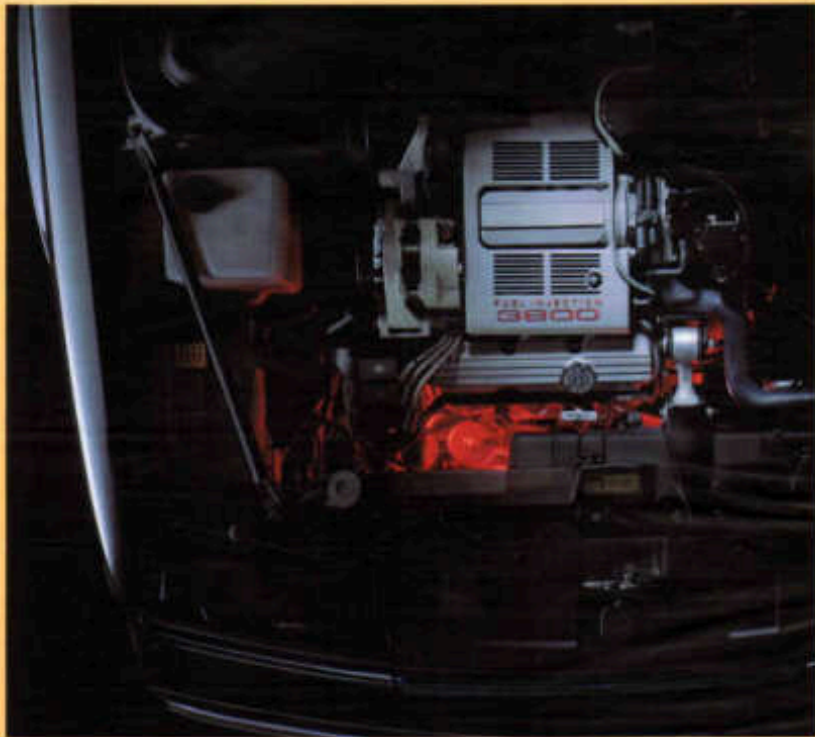

With the introduction of the high-technology 3800 V6 with SFI, optional engines became extinct.

When Oldsmobile offered the 3800 sequential port fuel-injected V6 engine in Toronado, Touring Sedan, Ninety Eight and Eighty-Eight

one year ago, it was a huge and unqualified success.

The 3800 engine has proven to be so capable that no additional engine choice need be made available.

The 3800 V6 engine with sequential port fuel injection is a highly advanced power plant incorporating lightweight metals and state-of-the-art technology that delivers outstanding performance (165 hp) and remarkably smooth and dependable operation.

Fuel is injected directly into each intake port by a high-pressure turbine pump with computer accuracy—as exactly the right time—with the right fuel/air mixture—at every

speed—for maximum performance.

When you step on the accelerator, the reaction is instantaneous. There is no hesitation, no lag. The 3800 engine moves you N/A. Confidently and smoothly. And does so with remarkable quiet.

Take the wheel of a 3800 V6-powered model, and you'll quickly discover what the New Generation of Oldsmobile is all about.

It's one great engine. And a test drive is in order.

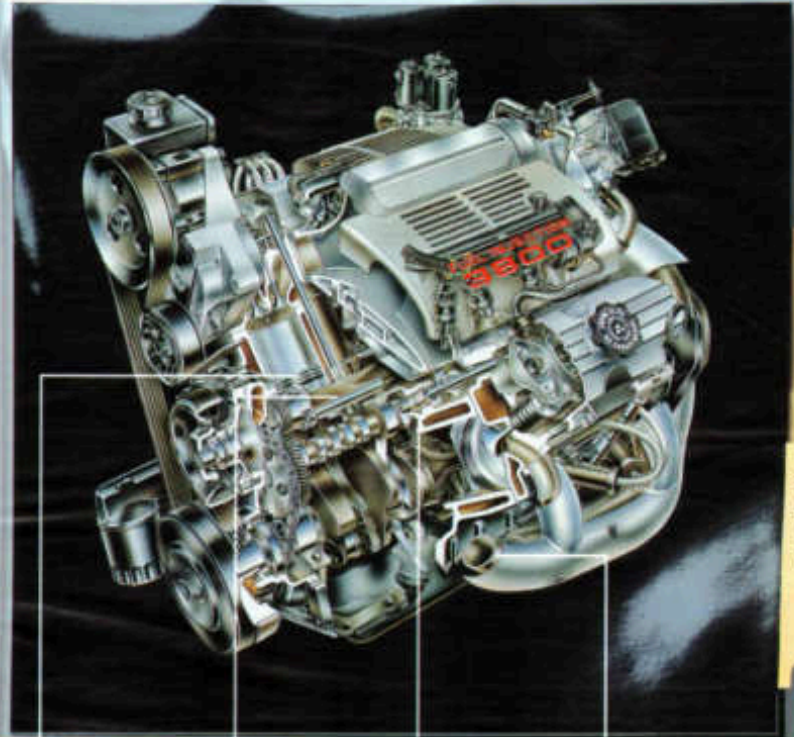

Lighter weight pistons perform with less friction and greater efficiency.

The 3800 is a 3.8-liter (231 cu. in.) displacement V6 with timing V6 configuration with sequential port fuel injection.

A counterbalancing balance shaft reduces vibration for smooth performance.

Sequential port fuel injection is activated by state-of-the-art sensors on camshaft which determine the exact timing of fuel intake for excellent cold starts and precise fuel metering.

Roller-tilt valve train and roller cams reduce power-robbing friction and contribute to smooth, efficient power.

An electronic control module determines the exact amount of fuel to be injected, based on incoming air mass, engine speed and temperature; throttle position and oxygen content in the exhaust, for efficient fuel use.

Overall performance is enhanced with forged pistons, manifold and larger diameter exhaust pipes.

Cylinder head pistons feature graphite laminate composite for excellent seal.

ROLLER-TILT VALVE TRAIN

COUNTERBALANCING BALANCE SHAFT

THE ALTIMORE

THE PERFORMANCE FEATURES



A few words about Oldsmobiles that exceed the speed limit without breaking the law.

You won't find these Oldsmobiles on Elm Street. You will find them, specially modified and tuned, on America's landmark race courses. Instead of breaking laws, they are breaking records in record numbers. On oval tracks. On drag strips. In their races.

The Oldsmobile victories keep coming, but Oldsmobile doesn't go racing just for the glory. We're there to test new ideas and their mettle, under the most grueling conditions. Oldsmobile performance is perfected on the race track, as well as the test track.

It pays off. Last year, before the revolution any Quad-4 engine entered a single show room, a specially modified, turbocharged engine was put to the test in the experimental Oldsmobile Arrowhead. On August 27, 1982 it set a new closed-course world land speed record of 257 miles per hour, breaking the eight-year-old mark set by a turbocharged V6 Mercedes-Benz. It also set a new world record of 267 mph in the drag ride. The production Quad-4 engine is now available in Cutlass Calais.

Other benefits that racing has contributed to include disc brakes, fuel injection, semi-dynamic styling, tuned manifolds and, of course, improved performance and durability.

As for the glory? Here are just a few of our recent accomplishments with specially modified Oldsmobiles—

- Oldsmobile—Trenton, national road racing champion (IMSA) the last two years.
 - Oldsmobile—National Hot Rod Association Manufacturer's Trophy winner the last four years.
 - Fourteen new NHRA records for elapsed times and top speeds last year.
 - Cutlass Supreme, winner at Darlington, considered the toughest track on the NASCAR circuit.
 - Cutlass Supreme, winner of the Winston 500 at Tallahassee, the world's fastest grandstand.
 - Cutlass Supreme wins SCCA Trans-Am Race at Long Beach, beating Porsche, Audi and Mercedes in its class.
 - In the Winston World Championship Series, Oldsmobile posted 20 first place finishes—just last year.
- The New Generation of Oldsmobile is, quite obviously, a winner!



TROFEO

MODEL: Trofeo Coupe

POWER SOURCE: 3800 V6 engine with SFI

TRANSMISSION: Four-speed automatic overdrive

SUSPENSION: Four-wheel independent with automatic load leveling

BRAKES: Four-wheel power disc, anti-lock system



T

R

O

F

E

O

12

13



TROFEO

Isn't technology beautiful?

Oldsmobile Trofeo® is, perhaps, the most technologically advanced personal performance luxury coupe in the world.

It is an exciting balance of performance, comfort and high technology, dramatically wrapped in black trim and aerodynamic lines. With hidden headlamps and special ground effect, it is fully capable of slicing through air—and medocrity—with equal ease.

The 3800 V6 engine with sequential port fuel injection thrives with computer accuracy.

Braking is state-of-the-art with a Tires four-wheel anti-lock system standard. Front seats provide individual power controls for side bolsters, back contour and lumbar support. Seat back recliners are also power actuated. Leather is standard in seating areas.

Turn the key, and Trofeo is alive with electronic technology. Available is the new Visual Information Center. It allows you to store and recall up to 51 visual displays. The VIC fully integrates with the available mobile phone, which provides convenient memory speed dialing, touch screen dialing, automatic redialing and much more. It even provides complete hands-off operation.

Leather-wrapped steering wheel with touch controls for stereo and climate control, FES luxury Car Side and Handling, Twilight Sentinel and 15-inch aluminum-styled wheels are all standard.

Trofeo might well be a driver's dream car. And fortunately, dreams can come true.



The instant reflex microtechnology is extraordinary, yet simple to monitor. The 5th away steering wheel places radio and climate controls at your fingertips. A complete message center appears at the touch of a button, which includes information on fuel economy, driving range, remaining oil life and more. A Visual Information Center available. Works with an in-ear computer to provide full color presentation of engine functions, accessory operation, navigational display and more. The available mobile phone is fully integrated with the VIC, an Oldsmobile exclusive. Provides 99 memory locations, automatic redial, hands-off operation and more.

The Oldsmobile Trofeo interior, personal and sporty, features genuine perforated Moroccan leather in the seating areas.

For added strength and durability, Doorbin vinyl trims the roof, instrument panel and door panels.

The center console is highlighted with Starflex Cross, a graphic on metal look that is both striking and contemporary.





TORONADO

Personal luxury aside,
it's the pure sport
driving you'll savor.

Automobile. Tornado has always been a driver's car. Right from the beginning, when it was the first contemporary automobile with front-wheel drive.

The new generation Tornado creates a unique and sporty driving experience for today's drivers. With retractable bulge head lamps, sleek hood and rounded corners, Tornado is the very shape of personal sport performance. And that performance is premium—provided by the powerful 3000-sequential port fuel-injected V6. A strong, smooth and proven performer.

But trying is believing, so slip inside. Adjust the 6-way power driver seat and leather-wrapped tilt-away steering wheel to your liking, nudge the console-mounted 4-speed automatic overdrive transmission lever into gear—and go. With dispatch. And complete confidence.

Four-wheel independent suspension and automatic level control smooth the lumps and bumps while you enjoy the sport, controlled ride. Tornado keeps its composure, even on surfaces least with imperfections.

To bring it all to a halt, which you'll hate to do, are four-wheel power disc brakes standard, with Teyes anti-lock brakes available.

For your convenience, the sub provides extensions for added coverage and comfort. Overhead, a storage area for sunglasses, garage door opener, or (most importantly) your driving gloves.

The 1990 Tornado is one great sport. And you're invited to participate. So take the wheel. Take a test drive.



1. Tornado's exciting contour bucket seats in Primavera (also Choice), Fun (Medium Annapolis), Dark Rosewood, Dark Sapphire Blue, Dark Camel Jet and Medium Gray. Center console with zipper included.

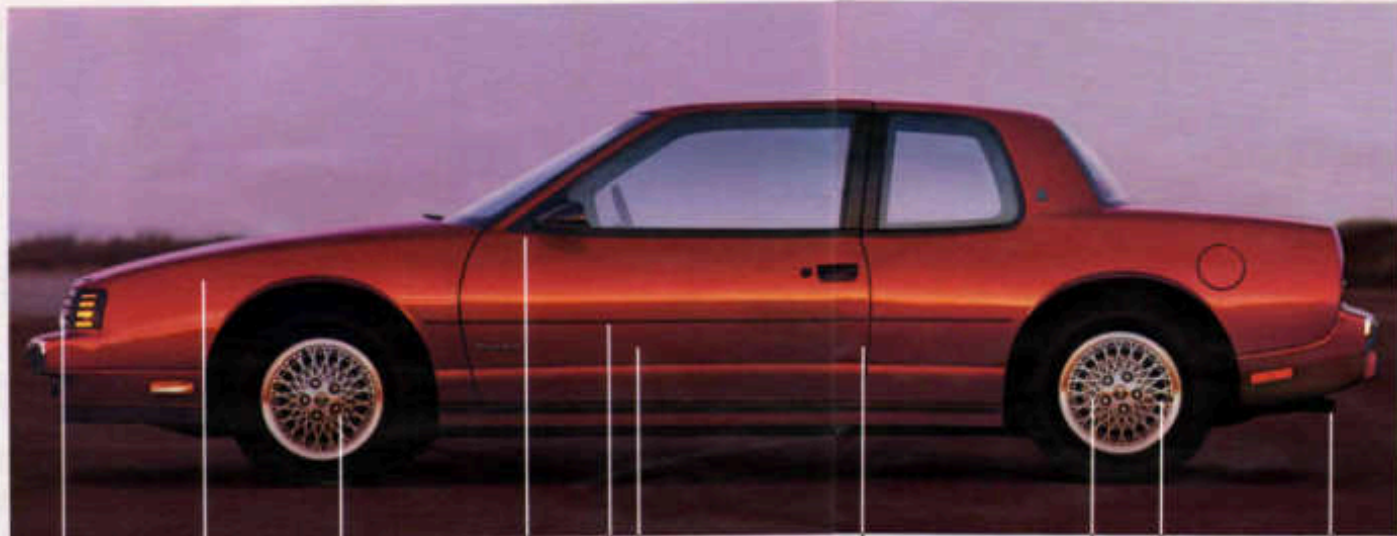

TROFEO

Advanced technology and serious engineering help make the Trofeo a driver's dream.

If you care to methodically work your way through the impressive facts, figures and specifications, they are at your disposal. And you are invited to do so.

However, there is a better and far more memorable way to acquaint yourself with this great driver's car. And that's behind the wheel.

In fact, if you're looking for some straight answers about road handling and maneuverability, behind the wheel is the only place to air.

Adjustable composite
Autogen headlamps
with four high
beam modes

3800 lb with 383

Four-wheel independent
FES Touring Car Ride
and Handling suspension

Electronic analog instrumentation
with tachometer and reminder package

Four-speed automatic
overdrive transmission

Ergonomically engineered seats

Two-sided galvanized steel
body/light composite

Four-wheel power
disc brakes
with anti-lock

Automatic
leveling system

Dual exhaust outlet

TROFEO/TORNADO POWERTRAIN SPECIFICATIONS

ENGINE	STANDARD
Displacement	3600 cc
Engine	49
Power hp (2000)	100 @ 4500
Max torque (2000)	200 @ 2500
Front (2000) (lb.)	3,800/3,400
Compression ratio	8.8 to 1
Fuel management	Electronic fuel injection (computerized)
Control system (2000)	1.8:1

DRIVELINE

Transmission	4-speed overdrive automatic
Front drive ratio	2.08 to 1

SUSPENSION/HANDLING

Front floor	4-wheel independent with FES and adjustable leveling system
Front turning diameter, curb to curb, left/right (in.)	38.0/38.0

*FES stands for FES

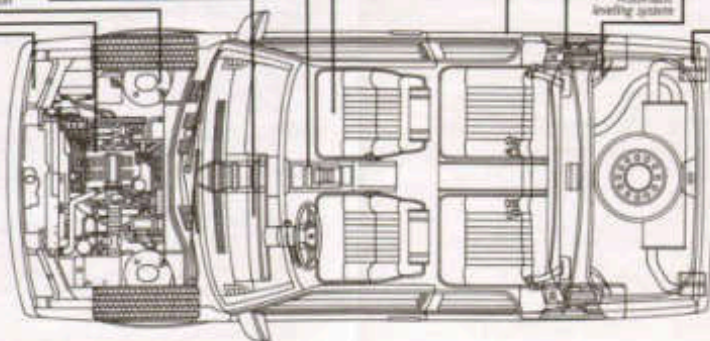

TROFEO/TORNADO DIMENSIONS

BODY/CHASSIS	COUPE
Wheelbase (in.)	107.5
Track, front/rear (in.)	55.5/55.5
Toe-in	2.75/3.5/4.15
Wheel size	13 x 5.5
Front/rear, front/rear	25.0/25.0
Front/rear (in.)	15.0
EXTERIOR	
Length (in.)	161.5
Width (in.)	73.4
Height (in.)	53.0
Curb weight (lb.)	3364
INTERIOR	
Headroom, front/rear (in.)	53.0/53.0
Legroom, front/rear (in.)	42.1/41.1
Shoulder room, front/rear (in.)	54.8/55.5
Trunk capacity	5
Passenger capacity (20, 11)	5/1

*HEADROOM IS MEASURED WITH SEATBELT IN POSITION

OLDSMOBILE TOURING SEDAN

MODEL: Oldsmobile Touring Sedan

POWER SOURCE: 3800 V6 engine with SFI

TRANSMISSION: Four-speed automatic overdrive

SUSPENSION: 4-wheel independent with automatic load leveling

BRAKES: Power front disc and rear drum, anti-lock system



O L D S M O B I L E T O U R I N G S E D A N

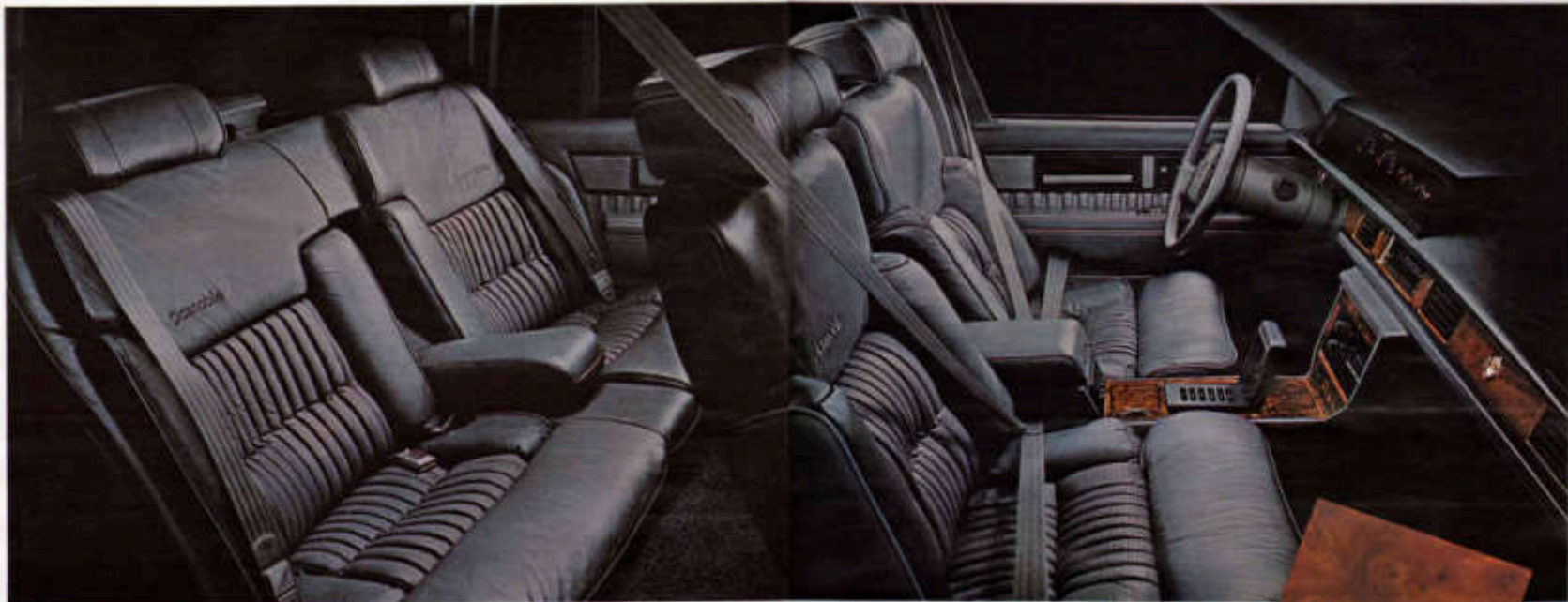

OLDSMOBILE TOURING SEDAN

Enjoy the exhilaration of world-renowned handling. And do it in absolute comfort.

The Oldsmobile Touring Sedan holds to a very lofty goal: offer an American touring car to not only equal, but surpass, such renowned nameplates as BMW 735i, Mercedes 190 and 300. Such cars pride themselves on handling, and rightly so.

The new generation Oldsmobile Touring Sedan's sophisticated suspension offers remarkable handling—as well as a most rewarding ride. You will find it comfortable, quiet, and very well controlled.



Instrumentation is complete, with calibrated tachometer, plus reminder package that includes low fuel, low coolant, low washer fluid and much more. Leather-wrapped steering wheel with touch controls for doors and climate control. 2. It power adjustments for ultimate comfort.

Inside, Touring Sedan takes ergonomics to new heights. The Lear Sleeger bucket seats are deep and thick. They feature individual controls for 11 power adjustments, including seat back recliners, side bolsters, lumbar and thigh, plus articulating headrest. Genuine leather, of course, trims the seating areas.

Touring Sedan will change your perception of what a road car can be—and will do so in comfort. Absolutely.



The genuine article. Like few cars in the world, Oldsmobile Touring Sedan provides rich bust without an instrument panel and center console.

For strength and durability, seats and door panels are trimmed in Dacron vinyl.

Give-it-thy Manasco perforated leather graces the seating areas. Impressive luxury refined details.



OLDSMOBILE TOURING SEDAN

Few cars look this good
on paper.

Or at the country club, for that matter. Oldsmobile Touring Sedan is beautifully styled and flawlessly engineered, inside and out.

Take the wheel and expect much of the Touring Sedan. On high speed expressways or challenging back roads, Oldsmobile Touring Sedan will not disappoint.

In fact, with your very first test drive, you'll know that this magnificent piece of machinery takes a back seat to no one.



High capacity cooling system

3800 lbs with V-7

Quick ratio rack and pinion power steering

Four-wheel independent, FES Steering Car Ride and Handling suspension. Automatic load leveling

Precision transmission with lockshifter

Four-speed automatic overdrive transmission

Two-sided patented steel for added corrosion protection

Four-wheel disc ABS braking system

Luggage compartment cargo net

OLDSMOBILE TOURING SEDAN POWERTRAIN SPECIFICATIONS

ENGINE	STANDARD
Displacement	3800 cc
Engine	V-6
Power (SAE) (CVT)	165 @ 4800
Net torque (SAE) (ft. lb.)	210 @ 2000
Compression ratio	9.8 to 1
Fuel Management	Electronic Fuel Injection (EFI) (Electronic Port)
Cooling system (SAE)	11.7

DRIVE/VEHICLE

Transmission	4-speed overdrive automatic
Front drive shaft	2.08 to 1

SUSPENSION/HANDLING

Front/Rear	4-wheel independent with FES and automatic leveling system
Front steering geometry: cast to curb, left/right (°)	304/403

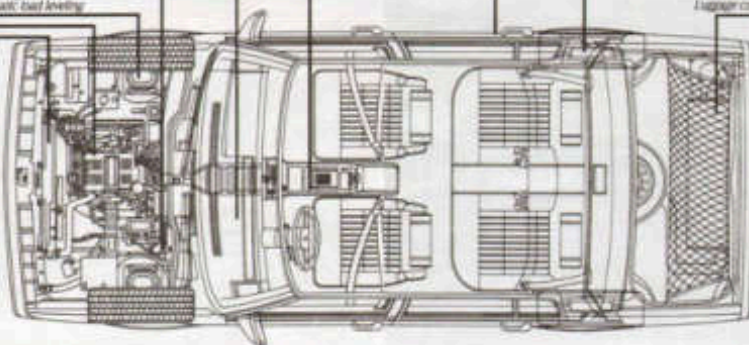

OLDSMOBILE TOURING SEDAN DIMENSIONS

BODY/CHASSIS	SEDAN
Wheelbase (in.)	112.0
Track, front/rear (in.)	56.0/56.0
Tire size	P215/60R16
Wheel size	16 x 7
Brake type, front/rear	Disc/Drum
Fuel tank capacity (U.S. gal.)	18.0

EXTERIOR	SEDAN
Length (in.)	188.4
Width (in.)	72.4
Height, incl. antenna (in.)	55.1
Curb weight (lbs.)	3,800

INTERIOR	SEDAN
Seating, front/rear (in.)	36.7/36.7
Seating, front/rear (in.)	43.4/43.3
Shoulder room, front/rear (in.)	56.0/54.0
Seating capacity	5
Front passenger (in.)	36.4

*Dimensions in inches unless otherwise noted.

NINETY-EIGHT REGENCY

MODELS: Ninety-Eight Regency Brougham Sedan (shown),
Ninety-Eight Regency Sedan
POWER SOURCE: 3800 V6 engine with SEI
TRANSMISSION: Four-speed automatic overdrive
SUSPENSION: Four-wheel independent with automatic load leveling
BRAKES: Power front disc and rear drum. Anti-lock system available

NOTE: Standard and available equipment varies, depending on the model you choose.
See the specifications and equipment section located on pages 44-52 of this catalog.



N I N E T Y - E I G H T R E G E N C Y



NINETY-EIGHT REGENCY BROUGHAM

Understatement of the year.

Ninety-Eight Regency Brougham is neither glitz nor show business. It is all business. It is, in fact, the last word in understated elegance.

Of course, all the expected conveniences are there. Electronic air conditioner, power-door locks, tilt-away steering wheel, Cruise Control, and 3600 V6 with SPI—all standard on this top-of-the-line sedan.

But beyond all that is the room and quiet you require. Driver and front passenger can adjust their seats individually. Additionally,

the driver side provides six-way power controls.

Ninety-Eight Regency Brougham. Every bit as logical as it is luxurious. Prove that to yourself. Test drive it. Then, test price it.

1. Individually adjustable SPI-45 Brougham front seat. 2. New driver-side Supplemental Inflatable Restraint system, designed into the steering wheel, is available. 3. Ninety-Eight Regency models offer a divided seat in 3100 1/2 sedan with center console.



Pretweave weaver fabrics highlight Regency Brougham's interior and are available in Dark Sapphire Blue, Medium Gray, Dark Garnet Red, Medium Antelope and Dark Rosewood.

Wood-grain applique adds a gracious note of elegance to the instrument and door panels.

Seams-grain leather is available in the seating areas (shown above). Color-matched Donkin's vinyl is used where heavy wear and ease of cleaning are important.





NINETY-EIGHT REGENCY

Its available anti-lock braking system could be the most logical luxury of all.

You're driving in a heavy rainstorm. Or the snow is flying—and accumulating on the road. Or you're in heavy, fast-moving traffic, and the driver in front of you suddenly applies the brakes. The available 3-wheel anti-lock braking system assists you and your Ninety-Eight Regency in stopping as quickly as possible, under most road conditions, while helping you maintain steering control.

When you apply the brakes in an emergency situation, ABS goes to work for you. A microprocessor assists you by sending electronic commands to modulate brake pressure up to 15 times per second. The system makes instant and automatic corrections to provide stable stopping power—when you need it most.

And that can be almost as comforting as the lengthy list of value-adding standard features. Air conditioner, power side windows, power door locks, tinted glass, 18-way power driver seat, AM/FM stereo with cassette, digital clock, 3800 sequential port fuel injected V6, automatic overdrive transmission, and four-wheel independent suspension with automatic load leveling are all included.

A new supplemental inflatable restraint system is available for the driver side.

And since you're so relaxed and comfortable, why not lean back and enjoy the remarkable sound of the electronically-tuned Decca stereo sound system. Or enjoy the ultimate in recorded sound with the available new Decca compact disc 6-speaker directional sound system.

All this at a price that is music to your ears. The logical and affordable Ninety-Eight Regency. What could be more in tune with today?

Photos, above left: Decca anti-lock braking system, electronic drawing. Wet pavement proving instant braking aid. Left: Ninety-Eight Regency sedan.

NINETY-EIGHT REGENCY

Beneath its gleaming high gloss finish, you see the logic of it all.

The closer you look, the more logical the Ninety-Eight Regency becomes.

It offers solid engineering, painstaking attention to detail, as well as bountiful luxury and an impressive array of standard power and convenience features.

But Ninety-Eight Regency also has its practical side—with two-sided galvanized body panels for added corrosion protection—and a price you'll find surprisingly affordable. Thousands of dollars less than many other luxury cars, foreign and domestic.*

Ninety-Eight Regency, a logical choice indeed.

*Comparison based on MSRP levels of equipment lists.



NINETY-EIGHT REGENCY POWERTRAIN SPECIFICATIONS

	STANDARD
ENGINE	
Displacement	3800 cc
Engine	V6
Block type (cc)	191 cc/4800
Net torque (lb-ft)	215 @ 2000
Net torque (N·m)	2,900 @ 2,700
Stroke (in.)	8.5 to 1
Compression ratio	
Fuel management	Dynafuel fuel injection (Sequential port)
Control methods	11.7
DRIVELINE	
Transmission	4 speed, overdrive automatic
Final drive ratio	1.98 to 1
SUSPENSION/HANDLING	
Front flex	4 wheel independent with electronic leveling system
Front turning diameter, curb to curb, left/right (ft.)	39.4/40.0

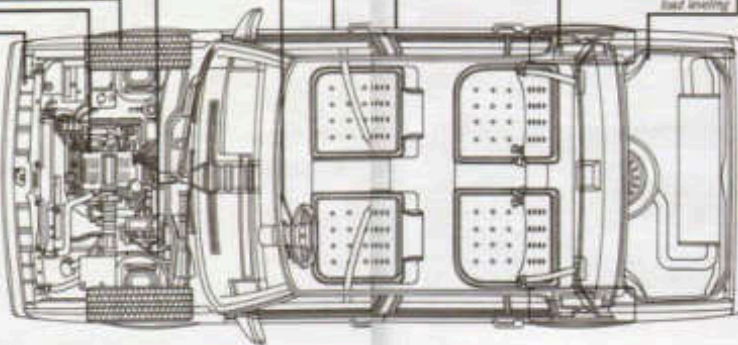

NINETY-EIGHT REGENCY DIMENSIONS

SEDAN	SEDAN
Wheelbase (in.)	110.0
Track, front/rear (in.)	60.5/60.0
Tire size	P195/70HR14
Wheel size	14 x 9
Steering type, front/rear	Disc/Steer
Fuel type (gas/diesel)	18.0
EXTERIOR	
Length (in.)	196.4
Width (in.)	72.4
Height (in.)	56.1
Curb weight (lb.)	3334
INTERIOR	
Passenger, front/rear (in.)	38.7/39.1
Legroom, front/rear (in.)	42.4/41.0
Shoulder room, front/rear (in.)	56.8/56.0
Seating capacity	5
Curb weight (lb.)	35.4

*Based on 1998 MSRP. Excludes a limited list of equipment.

EIGHTY-EIGHT ROYALE

MODELS: Eighty-Eight Royale Brougham Sedan (shown below and right), Eighty-Eight Royale Brougham Coupe (shown far right), Eighty-Eight Royale Sedan, Eighty-Eight Royale Coupe

POWER SOURCE: 3800 V6 engine with SFI

TRANSMISSION: Four-speed automatic overdrive

SUSPENSION: Four-wheel independent

BRAKES: Power front disc and rear drum. Anti-lock system available

NOTE: Standard and available equipment varies, depending on the model you choose. See the specifications and equipment section located on pages 44-52 in this catalog.



E I G H T Y - E I G H T R O Y A L E



EIGHTYEIGHT ROYALE BROUGHAM

Now every tourist can
travel first class.

It's big and roomy. Solid and substantial. Eighty-Eight Royale Brougham is a long-standing favorite of American families. For good reason. Here is first-class comfort for six.

Top-of-the-line Brougham features a 55/45 divided front seat with individual controls and full foam construction.

The ride, of course, is big and smooth with four-wheel independent suspension.

But your needs go beyond room and comfort. And so does Eighty-Eight Royale

Brougham. For performance, the 3600 V6 engine with 5F1 and four-speed automatic overdrive transmission are standard. Both are so smooth and quiet as to go virtually unnoticed. Yet, acceleration is outstanding.

On sedan models, a Supplemental Inflatable Restraint system is available for the driver's side. An anti-lock brake system is also available.

Standard air conditioning and stereo with extended range speakers add to the value.



1. All Eighty-Eight Sedans may be ordered with the Supplemental Inflatable Restraint system, and also on the driver side and designed into the steering wheel. 2. Royale Brougham owners can order optional leather for the seating areas. 3. Custom floor mats are standard on all Royale models. Available in Lucerne and winter in Dark Sapphire Blue, Medium Gray, Dark Garnet Red and Medium Beechwood.

Interior shown shown equipped with Supplemental Inflatable Restraint system.

The Royale Brougham interior is highlighted with elegant, yet hard-wearing and easy-cleaning Summit Knit vinyl. Choose from Dark Sapphire Blue, Medium Gray, Dark Garnet Red and Medium Beechwood.

Division vinyl door and seat trim looks smart, wash well, and wipes clean with a damp cloth.

Handsome and contemporary Sheffield Case brushed aluminum accents highlight throughout.





EIGHTY EIGHT ROYALE

At the flick of a wrist, this perfectly respectable Royale can turn into an exciting road machine.

You may well be a family provider. But you can still reward your instincts as a serious driver.

Transforming this fine family steed into a road-hugging performance vehicle is really easy to do.

Simply order the available FE3 Tuning Car Rate and Handling package.

With FE3, the resulting ride is nothing less than spectacular. Lean and sway are reduced to a pretense. Steering is quick and precise. The ride, steady and sure.

In short, a big ride can also be big fun.

With the premium performance of the standard 3800 V6 with SPI, acceleration, especially at lower speeds, is outstanding. In fact, with a new 2.64 transaxle ratio, it's quicker than ever!

All this from an automobile that has been a family favorite for years. First and foremost, Eighty-Eight Royale is a roomy, substantial car, solidly built for years of dependable service. Curb weight: over 3,100 pounds. Trunk capacity: over 16 cubic feet. Passenger capacity room for six in comfortable and supportive full foam seats.

Eighty-Eight Royale is a lot of car for the money. As a matter of fact, the following features are all standard. Air conditioner, AM/FM stereo radio with extended range rear speakers, digital clock, trip odometer, power steering and brakes, headlamp-on reminder, side window detaggers, tinted glass, composite halogen headlamps, body side molding, deluxe wheel discs, and more.

Head on down to your Oldsmobile dealer and take a test drive. You'll find that an FE3-equipped Eighty-Eight Royale can handle a winding stretch of pavement as admirably as it handles groceries, the kids, Aunt Nellie and the family dog.

Left, Eighty-Eight Royale Coupe. Above left, Eighty-Eight Royale Sedan.

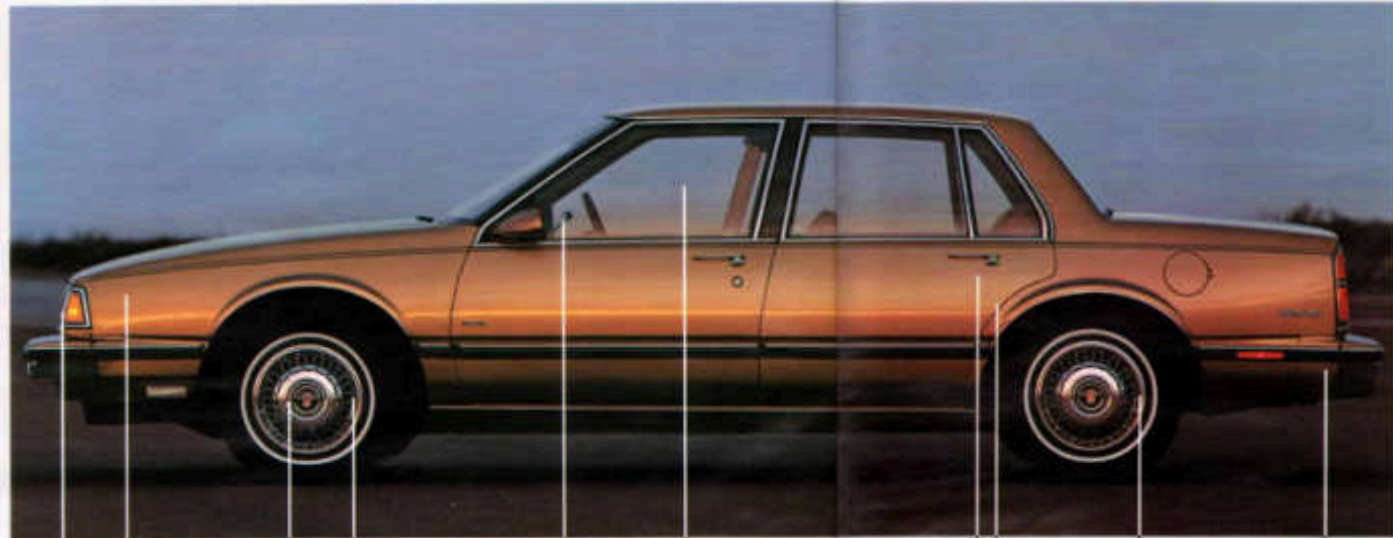

EIGHTY EIGHT ROYALE

It's filled with the features that fill today's family needs.

For most cars today, comfortably accommodating six passengers is more than a tall order. It is out of the question. With a new generation Oldsmobile Eighty-Eight Royale, however, it's simply a matter of fact.

Add Eighty-Eight Royale's impressive performance and smooth, substantial ride, and it is one tough act—and value—to match.

And maybe best of all, Eighty-Eight Royale is built to keep on delivering, year after year. It's more than just another pretty face. It's one tough cookie.

1800 cc with 12V
Composite headlamps

Front wheel drive

Lower rack and pinion steering

Four speed automatic overdrive transmission

Divided glass all around

Multicolor/high-gloss enamel finish

Two-stud advanced steel for added corrosion protection

Four-wheel independent suspension

Long-life stainless steel exhaust system

EIGHTY-EIGHT ROYALE POWERTRAIN SPECIFICATIONS

ENGINE	STANDARD
Displacement	2800 cc
Engine	190 cc 4850
Stroke (in./mm)	7.0/177.8
Peak Torque (ft.-lb./kg.)	3.0/41.2
Compression ratio	8.5 to 1
Fuel management	Electronic Fuel Injection (Research Jet)
Control system (cc)	11.7
DRIVE/LINE	
Transmission	4-speed automatic
Front drive shaft	1.98 to 1
SUSPENSION/HANDLING	
Front/Rear	4-wheel independent
Front turning diameter, curb to curb, left/right (ft.)	30.4/40.0

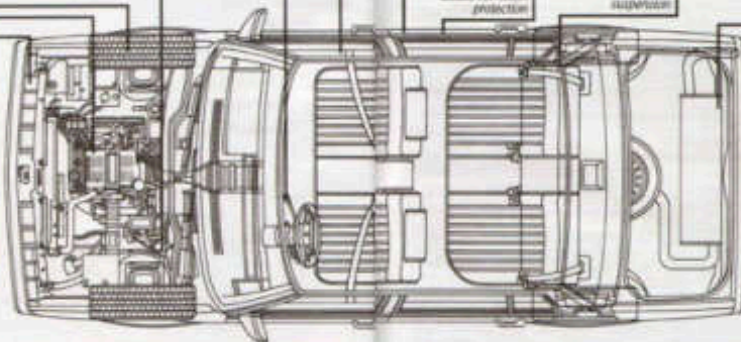

EIGHTY-EIGHT ROYALE DIMENSIONS

BODY/CHASSIS	COUPE	SEDAN
Wheelbase (in.)	108.1	108.1
Track, front/rear (in.)	54.7/54.7	54.7/54.7
Wheel size	P205/75R14	P205/75R14
Wheel size	14 x 6	14 x 6
Front fender, front/rear	Dist./Dist.	Dist./Dist.
Front fender, center	19.0	19.0
EXTERIOR		
Length (in.)	196.1	196.1
Width (in.)	72.4	72.4
Height (in.)	54.7	54.7
Curb weight (lbs.)	3794	3929
	3944 lb.	3943 lb.
INTERIOR		
Headroom, front/rear (in.)	38.1/38.0	38.0/38.0
Legroom, front/rear (in.)	42.4/42.4	42.4/42.4
Shoulder room, front/rear (in.)	53.2/53.2	53.2/53.2
Trunk capacity (cu. ft.)	6	6
Trunk capacity (cu. ft.)	16.2	16.2



CUSTOM CRUISER

Get "two" luxury vehicles for the price of one.

Place your left hand over the rear section of the Custom Cruiser pictured to the left, and it becomes a big, smooth-riding luxury car. Which it is.

Take your hand away, and Custom Cruiser becomes one of the largest, most capable station wagons on earth. Which it also is.

As a workhorse, its Clydesdale size. With 82.2 cubic feet of cargo space, it can easily handle a lawnmower or the materials for almost anything you can build.

But when the workday is done, Custom Cruiser goes high life. You'll relax and unwind on full-bam seats and be swept away with an Oldsmobile ride as big as Custom Cruiser itself.

Power is provided by a 5.0-liter V8 engine and four-speed automatic overdrive transmission, so you're never shortchanged on performance. It's impressive.

Incidentally, Custom Cruiser is ideal for long trips. Equipped for towing, you can hitch up your boat or trailer and go with confidence.

Custom Cruiser. It has what it takes to meet the needs of the day. Or night. And do so in Oldsmobile style.



CUSTOM CRUISER CARGO AREA DIMENSIONS

3-BEAT MODELS

Maximum cargo weight (lbs.)	81.7
Floor length from back of front seat to end of floor surface (in.)	90.2
Floor length from back of second seat to end of floor surface (in.)	105.6
Maximum horizontal distance from top of rear load seat back to inside of edge of left (in.)	87.0
Maximum distance between anchorages of floor ties (in.)	48.2
Floor and opening width at left (in.)	48.2
Maximum height of rear loading, tie-down (in.)	26.1
Maximum cargo height (in.)	29.7

1. The 45135 divided front seat is flared when selected. Choose from Dark Sapphire Blue, Medium Gray, Dark Green and Medium Birchwood. 2. Passenger capacity for eight, with standard rear-facing third seat. 3. Tilted storage area for your valuables. 4. The flat, fully carpeted cargo floor is 90.2 inches long from back of the front seat to the end of the floor surface. 5. Available roof rack provides added carrying capacity.



THE FINISHING TOUCH

Standard and available 1989 wheel trim.

For 1989, Oldsmobile offers a wide range of wheel trim choices. Some sporty. Some

formal. All tastefully styled to be a beautiful finishing touch. One is just right for your new Oldsmobile.

■ **7. Aluminum Spoke Wheel with Lock, 15"** Standard on Toronado and Regency. ■ **2. Aluminum Spoke Wheel with Lock, 16"** Standard on Touring Sedan. ■ **3. Aluminum Spoke Wheel with Lock, 15" (FR)** Available on all Eighty-Eight models (includes P205/70R15 Side Blackwall tire) and Ninety-Eight Regency models. Standard on Ninety-Eight Regency Brougham (includes P205/70R15 Side Blackwall tire). Also included with FE3. ■ **4. Simulated Wire Wheel Disc with Lock (FR)** Available on all Eighty-Eight models

(includes P205/75R14 White-Slope tire) and Ninety-Eight Regency Brougham models (includes P205/70R15 White-Slope tire). Standard on Ninety-Eight Regency Sedan. ■ **5. Deluxe Wheel Disc.** Standard on all Eighty-Eight models. ■ **6. Simulated Wire Wheel Disc with Lock (FR)** Available on Custom Cruiser. ■ **7. Deluxe Wheel Disc.** Standard on Custom Cruiser.

AFFORDABLE OPTION PACKAGES TO PERSONALIZE YOUR NEW GENERATION OLDSMOBILE.

EIGHTY-EIGHT REGAL OPTION PACKAGES (All Orders must include one ONE Option Package)		Eighty-Eight Regal			Eighty-Eight Regal Brougham			
		15A	15B	15C	15D	15A	15B	15C
Seat, 55-45 Divided Bench with Dual Consoles (Includes Armrest, Front Seat Storage)		•	•	•	•			
Wiper System, Pulse (Required with A12)		•	•	•	•			
Cruise Control, Electronic with Resume and Acceleration Features		•	•	•	•			
Steering Wheel, Tilt-Away (Required with A12) (Required with A13 or U32—Brougham)		•	•	•	•			
Convenience Group, includes Under Hood and Trunk Lamps, Mirror, Vanity Mirror and Chrome Trim		•	•	•	•			
Door Locks, Power		•	•	•	•			
Windows, Power Side (Required with U74 or U10—Brougham)		•	•	•	•			
Floor Mats, Auxiliary front and Rear Carpet		•	•	•	•			
Moldings, Door Edge Guard—Bright		•	•	•	•			
Armrests, Power Rear Quarter		•	•	•	•			
Seat Backs, Reclining Manual—Driver and Passenger Side		•	•	•	•			
Seat Adjuster, 6-Way Power, Divided Bench Seat—Driver Side		•	•	•	•			
Trunk-Lid Lock Release, Power		•	•	•	•			
Reminder Package, includes indicators for Low Fuel, Low Coolant, Low Oil Pressure, High Engine Temperature and Brake Warning (Required with U29)		•	•	•	•			
Convenience Mirror Group, includes Illumination Package for Front Door Locks and Interior, Color-Coordinated, Electrically Operated Outside Driver and Passenger Side Mirrors, Passenger Side Illuminated Vanity Mirror, Front Fender Cornering Lamps, and Interior Lamps—includes Front Header Douchette and Dual Lane Reading Feature		•	•	•	•			
Air Conditioning, Automatic Electronic Comfort Control (Required with U52)						•		
Lamp, Open Entrance							•	

CUSTOM CRUISER OPTION PACKAGES

(All Orders must include one ONE Option Package)

CUSTOM CRUISER OPTION PACKAGES		Custom Cruiser			
		15A	15B	15C	15D
Driver Convenience Package, includes Wiper System, Pulse, Cruise Control, Electronic with Resume and Acceleration Features and Steering Wheel Tilt-Away			•	•	•
Wheel Discs, Simulated Wire with Locks			•	•	•
Moldings, Door Edge Guard—Bright—includes in Body Side and Taggate Wood Grain Paneling Molding (Package 15C or 15D)—color Brown			•	•	•
Floor Mats, Auxiliary front and Rear Carpet			•	•	•
Mirrors, Chrome, Electrically Operated, Outside—Driver and Passenger Side			•	•	•
Seat Back, Reclining Manual—Passenger Side			•	•	•
Armrests, Power Rear Quarter			•	•	•
Reminder Package, includes indicators for Low Fuel, Low Coolant, Low Oil Pressure, High Engine Temperature and Brake Warning (Required with U14)			•	•	•
Deluxer, Chrome Rear Bumper			•	•	•
Accent Strips, Body—Color Code Selection (Required on Accent Strip Section of Wholesale Car Order (WCA with Package 15A, 15C or 15D)			•	•	•
Door Locks, Power—includes Taggate Lock Release			•	•	•
Windows, Power Side			•	•	•
Luggage Carrier, (Roof)—Chrome—includes Rear Window Air Deflector			•	•	•
Moldings, Lower Body Side			•	•	•
Mirrors, Illuminated Mirror Vanity—Driver and Passenger Side			•	•	•
Seat Adjuster, 6-Way Power, Divided Bench Seat—Driver Side			•	•	•
Radio, Delco 670 AM/FM Stereo with Seek-Scan, Auto Reverse Cassette and Digital Display Clock			•	•	•
Body Side and Taggate Paneling, Wood-Grained Vinyl—includes Door Edge Guard Molding—color Brown (Standard Body Side Molding absent when ordered)			•	•	•
Air Conditioning, Temperature			•	•	•
Lamps, Combination Dome and Dual Lane Reading			•	•	•
Illumination Package, Front Door Locks and Interior			•	•	•
Lamps, Front Fender Cornering			•	•	•
Mirror, Exterior Lamps, Front and Rear			•	•	•
Seat Adjuster, 6-Way Power, Divided Bench Seat—Passenger Side			•	•	•

NINETY-EIGHT REGENCY/TOURING SEDAN OPTION PACKAGES

(All Orders must include one ONE Option Package)

NINETY-EIGHT REGENCY/TOURING SEDAN OPTION PACKAGES		Ninety-Eight Regency		Ninety-Eight Regency Brougham		Touring Sedan		
		15A	15B	15C	15A	15B	15C	15A
Floor Mats, Auxiliary front and Rear		•	•		•	•		

NIGHT-DRIVING ASSISTANCE PACKAGE (All Options must include only ONE Option Package)	Heavy-Duty Tires			Heavy-Duty Tires			Starting Price
	15A	15B	15C	15A	15B	15C	
Power Mirrors, Auxiliary Front and Rear							
Wiper System, Power (Required with A23)		*	*		*	*	
Cruise Control, Electronic with Resume and Acceleration Features		*	*		*	*	
Steering Wheel, 10-Away (Required with A23)		*	*		*	*	
Trunk Lid Lock Release (And Trunk Lid Pull-Down—Sbaughtry) Power		*	*		*	*	
Antenna, Power Rear Quarter		*	*		*	*	
Mirrors, Automated View-Mirrors—Driver and Passenger Side		*	*		*	*	
Seat Belts, Buckling Mirrors—Driver and Passenger Side		*	*		*	*	
All-Conditions, Automatic Electronic Climate Control (Required with M02)		*	*		*	*	
Seat Adjuster, 5-Way Power, Heated Bench Seat—Passenger Side		*	*		*	*	
Lamps, Front/Fender Cornering		*	*		*	*	
Information System, Driver—processes Digital Readout (English/Metric) for Fuel Economy, Instantaneous and Average, Range and Fuel Used, Time and Distance, Time, plus Average Miles Per Hour, Date, Estimated Time of Arrival and Total Distance to Destination. Also provides automated service reminder showing Estimated Oil Life remaining (with rest of Oil Change is required). Digital gauge information for Tachometer, Waterfall and Coolant Temperature		*	*		*	*	
Convenience Mirror Group, includes Reminder Package (Indicators for Low Fuel, Low Washer Fluid and Headlamp Oil). Also includes Audible Alarm for Low Fuel, Engine Temperature, Brake Pressure and Low Oil Pressure, Illumination Package, Front Door Locks and Interior, Twilight Sentinel, Electric Remote Control Fuel Filler Door Lock, Automated Radio/Alarm, Inside Day/Night Mirror and Color-Coordinated Electrically Operated Outside Mirrors—Driver and Passenger Side (Required with L30)		*	*		*	*	
Steering Wheel Touch Control, includes Steering Wheel, Leather-Wrapped (174 or 17C required)—AA, with A23		*	*		*	*	
Door Locks, Automatic Electric—Driver Side		*	*		*	*	

TECHNADO-TRÉFIC OPTION PACKAGES (All Options must include only ONE Option Package)	Technado			Techno 15A
	15A	15B	15C	
Seat Adjuster, 5-Way Power, Passenger Side		*	*	
Lamps, Front, Upper Quarter Courtesy and Single Lane Reading		*	*	
Illumination Package, Front Door Locks and Mirror		*	*	
Mirrors, Automated View-Mirrors—Driver and Passenger Side		*	*	
Mirrors, Rear, Electrically Operated Outside—Driver and Passenger Side, Outer Side Electric Mirrors		*	*	
Trunk Lid Pull-Down, Power		*	*	
Twilight Sentinel		*	*	
Door Locks, Automatic		*	*	
Mirrors, Inside Automatic, Electrochromic Day/Night		*	*	
Lock, Electric Remote Control, Fuel Filler Door		*	*	
Steering Wheel, Touch Control		*	*	

STANDARD AND AVAILABLE EQUIPMENT*

POWERTRAIN

Engine, 3600 V6 with Sequential Fuel Port Injection (SFI)		*	*	*	*	*	*	*	*
Engine, 5.0 liter V6, 8-Valve (V2)		*	*	*	*	*	*	*	*
Heater, Engine Block (N02)		*	*	*	*	*	*	*	*
Transmission, Automatic with Overdrive (M02)		*	*	*	*	*	*	*	*

CHASSIS	15A	15B	15C	15A	15B	15C	15A	15B	15C
Batteries, Freedom		*	*	*	*	*	*	*	*
Batteries, Freedom High-Capacity		*	*	*	*	*	*	*	*
Brakes, Power Front-Wheel Disc		*	*	*	*	*	*	*	*
Brakes, Power Front Disc and Rear Drum		*	*	*	*	*	*	*	*

* Standard equipment. ** Available equipment. *** Available only when other options are selected. * or ** refers to 15A. * or ** refers to 15B. * or ** refers to 15C. * or ** refers to 15A. * or ** refers to 15B. * or ** refers to 15C.

Braking System, Anti-Lock (A3)		*	*	*	*	*	*	*	*
Braking System, Anti-Lock (M4)		*	*	*	*	*	*	*	*
Coating Equipment, High-Capacity—includes Battery System, High-Capacity Recommended for Solar Tinting (Battery system is standard on Technado models) (N02)		*	*	*	*	*	*	*	*
Deviation		*	*	*	*	*	*	*	*
Differential, Limited Slip (D02)		*	*	*	*	*	*	*	*
Ignition System, High-Energy		*	*	*	*	*	*	*	*
Landing System, Automatic Electric—Recommended for Towing (M4)		*	*	*	*	*	*	*	*
Steering, Power		*	*	*	*	*	*	*	*

STANDARD AND AVAILABLE EQUIPMENT

CHASSIS (continued)

CHASSIS (continued)	15A			15B			15C		
	15A	15B	15C	15A	15B	15C	15A	15B	15C
Steering, Power Rack-and-Pinion		*	*	*	*	*	*	*	*
Suspension System, Four-wheel fully independent with MacPherson front struts, Coil Springs of rear		*	*	*	*	*	*	*	*
Suspension System, Four-wheel fully independent with MacPherson front struts, plus Automatic Electronic Locking—includes Special Towing Car Rate and handling system		*	*	*	*	*	*	*	*
Suspension System, Four-wheel fully independent with MacPherson front struts, plus Automatic Locking and Coil Springs of rear (Electronic Locking on Sbaughtry)		*	*	*	*	*	*	*	*
Suspension System, Independent front with Coil Springs and Stabilizer Bar, plus Coil Springs of rear		*	*	*	*	*	*	*	*
Suspension System, Level 8 Rear Ride and Handling includes Rear Ride Front and Rear Shock Absorbers, Higher Rate Front and Rear Springs, Larger Front Stabilizer Bar and Rear Stabilizer Bar, plus Coil Springs of rear		*	*	*	*	*	*	*	*
Suspension System, Level 8 Front Ride and Handling includes Rear Ride Front and Rear Shock Absorbers, Higher Rate Front and Rear Springs, Larger Front Stabilizer Bar, Rear Stabilizer Bar		*	*	*	*	*	*	*	*
Suspension System, Level 8 Load-Carrying includes Rear Ride Front and Rear Shock Absorbers, Higher Rate Front and Rear Springs, Larger Front Stabilizer Bar and Rear Stabilizer Bar, plus Leveling System, Automatic Electric and 2.97 Ratio Transaxle (770), includes Coating Equipment, High-Capacity (N02) and Battery, High-Capacity (N2)		*	*	*	*	*	*	*	*
Suspension System, Level 8 Towing (Car Rate and Handling consists of Special Suspension Components and Special Steering Gear, plus Steering Wheel, Leather-Wrapped Steering Yoke, Automatic Electric Mirrors, Aluminum-Styled 15" (N02) and Tires, P225/65R15 Performance Steel-Belted Radial-Ply, Blackwall and 2.97 Ratio Transaxle (770), includes Coating Equipment, High-Capacity (N02) plus Battery, High-Capacity (N2)		*	*	*	*	*	*	*	*
Suspension System, Level 8 Towing (Car Rate and Handling consists of Special Suspension Components and Special Steering Gear, plus Steering Wheel, Leather-Wrapped Steering Yoke, Automatic Electric Mirrors, Aluminum-Styled 15" (N02) and Tires, P225/65R15 Performance Steel-Belted Radial-Ply, Blackwall and 2.97 Ratio Transaxle (770), includes Coating Equipment, High-Capacity (N02) plus Battery, High-Capacity (N2)		*	*	*	*	*	*	*	*
Suspension System, Level 8 Towing (Car Rate and Handling consists of Special Suspension Components and Special Steering Gear, plus Steering Wheel, Leather-Wrapped Steering Yoke, Automatic Electric Mirrors, Aluminum-Styled 15" (N02) and Tires, P225/65R15 Performance Steel-Belted Radial-Ply, Blackwall and 2.97 Ratio Transaxle (770), includes Coating Equipment, High-Capacity (N02) plus Battery, High-Capacity (N2)		*	*	*	*	*	*	*	*
Suspension System, MacPherson front struts with Techno Independent Rear, plus Automatic Locking System		*	*	*	*	*	*	*	*
Suspension System, Towing Car Rate and Handling with MacPherson front strut with Stabilizer Bar, plus Automatic Locking System		*	*	*	*	*	*	*	*
Tires, P225/70R15 Steel-Belted Radial-Ply, Blackwall—All Season		*	*	*	*	*	*	*	*
Tires, P225/75R14 Steel-Belted Radial-Ply, Blackwall—All Season		*	*	*	*	*	*	*	*
Tires, P225/75R14 Steel-Belted Radial-Ply, White Stripe—All Season (L01)		*	*	*	*	*	*	*	*
Tires, P225/75R15 Steel-Belted Radial-Ply, Blackwall—All Season		*	*	*	*	*	*	*	*

* Standard equipment. ** Available equipment. *** Available only when other options are selected. * or ** refers to 15A. * or ** refers to 15B. * or ** refers to 15C.

Tires, P225/65R15 Performance Steel-Belted Radial-Ply, Blackwall		*	*	*	*	*	*	*	*
Tires, P225/65R15 Performance Steel-Belted Radial-Ply, Blackwall—All Season		*	*	*	*	*	*	*	*
Tires, P225/75R15 Steel-Belted Radial-Ply, White Stripe—All Season		*	*	*	*	*	*	*	*
Towing Package—includes Optional 3.23 Towing Axle (N01), Heavy-Duty Cracking, High-Capacity Battery and 7 Wire Trailer Electrical Harness (N04)		*	*	*	*	*	*	*	*
Ventilation, No Fluo		*	*	*	*	*	*	*	*
Wheels, 14x6		*	*	*	*	*	*	*	*
Wheels, 15x6		*	*	*	*	*	*	*	*
Wheels, 15x7		*	*	*	*	*	*	*	*
Wheels, Aluminum-Styled with Locks		*	*	*	*	*	*	*	*
Wheels, Aluminum-Styled 15" with Locks—includes Tires, P225/70R15 Steel-Belted Radial-Ply, Blackwall—All Season (Tires are Special Rate on Registry Sbaughtry) (N02)		*	*	*	*	*	*	*	*
Wheel Discs, 15x6x8		*	*	*	*	*	*	*	*
Wheel Discs, Simulated Wheel with Locks		*	*	*	*	*	*	*	*
Wheel Discs, Simulated Wheel with Locks—includes Tires, P225/70R14 Steel-Belted Radial-Ply, White Stripe—All Season (Tires are Special Rate on Registry Sbaughtry, N01)		*	*	*	*	*	*	*	*

EXTERIOR STYLING

Accent Strips, Body (S01)		*	*	*	*	*	*	*	*
Antenna, Electric, Biting Glass Panel in Gray Tint (Headlamps is included when Option 025 is ordered) (C01)		*	*	*	*	*	*	*	*
Bumper Front, includes Amber Park/Turn Lamps		*	*	*	*	*	*	*	*
Bumper Guards, Front and Rear		*	*	*	*	*	*	*	*
Bumper Impact Strips, Front and Rear		*	*	*	*	*	*	*	*
Bumper Rub Strips, Front and Rear		*	*	*	*	*	*	*	*
Bumper, Gray Metallic, Front and Rear		*	*	*	*	*	*	*	*
Deluxe Steel, Luggage Compartment and Spare Tire Cover (and Trunk Lid on Towing Sedan)		*	*	*	*	*	*	*	*
Foglamps, Day		*	*	*	*	*	*	*	*
Foglamps, with Switch in Header Panel		*	*	*	*	*	*	*	*
Front Fenders, with Extended Air Duct		*	*	*	*	*	*	*	*
Grills, Black/Gray with Headlamp Covers		*	*	*	*	*	*	*	*
Headlamps, Composite Halogen		*	*	*	*	*	*	*	*
Headlamps, Composite Halogen, Retractable		*	*	*	*	*	*	*	*
Headlamps, Halogen Power Retractable		*	*	*	*	*	*	*	*
Headlamps, Single Halogen (High Beam)		*	*	*	*	*	*	*	*
Lamps, Backup with Neutral Density Lens and Body Color Bump		*	*	*	*	*	*	*	*
Lamps, Front Fender Cornering		*	*	*	*	*	*	*	*

STANDARD AND AVAILABLE EQUIPMENT

COMFORT/CONVENIENCE FEATURES (continued)

Information System. Driver - provides digital readout (英里/英里) for fuel economy, instantaneous and average, range and fuel used; Time and Triped Time, plus Average Mile-Per-Hour; Daily Estimated Time of Arrival and Total Distance to Destination. Also provides automated vehicle-rearview-shifting (Electronic Oil Life sensing (before next oil change is required). Digital gauge information for Tachometer, Voltmeter and Coolant Temperature (222).

Instrument Panel Gauge Cluster. with 120 mph Speedometer, Tachometer, Fuel, Oil Pressure, Water Temperature and Voltmeter - includes Reminder Passage indicators for Low Fuel, Low Coolant, Low Washer Fluid, plus audible alarms for Low Fuel, Engine Temperature, Brake Pressure, Low Oil Pressure and Low Coolant.

①-Standard equipment. ②-Optional equipment. ③-Available only when other options are selected. See dealer for details.

Model	8000	8000	8000	8000	8000	8000	8000	8000	8000	8000
Information System										
Instrument Panel Gauge Cluster										

Lock, Tach, Remote Control, Fuel Filter Door										
Mirror, Burnished Your Vanity-Older Side										
Mirror, Burnished Your Vanity-Passenger Side										
Mirror, Inside Automatic Day-Night										
Steering Wheel Touch Controls - includes Steering Wheel, LATCH (Whipst-DRK)										
Telephone, Mobile Keyed Control (222)										
Trunk Cargo Net										
Trunk Lid Lock Release, Power										
Trunk Lid Pull Down, Power										
Wiper, Sentinel										
Windows, Power Side (222)										
Wiper System, Pulse										

STANDARD EXTERIOR COLORS (Actual color paint chips available. Ask your salesperson.)

11 White	29 Dark Sapphire Blue Metallic	59 Dark Birchwood Metallic	76 Dark Garnet Red Metallic
13 Platinum Metallic	31 Dark Sapphire Blue Metallic	62 Light Beechwood Metallic	79 Burgundy Metallic
15 Medium Gray Metallic	40 White	67 Dark Antique Metallic	83 Light Rosewood Metallic
19 Black	41 Black	69 Medium Beechwood Metallic	85 Medium Rosewood Metallic
22 Light Sapphire Blue Metallic	52 Copper Sage	72 Medium Garnet Red Metallic	86 Light Antique Sage
26 Light Sapphire Blue Metallic	57 Light Beechwood Metallic	75 Medium Garnet Red Metallic	87 Medium Gray Metallic

AVAILABLE EXTERIOR COLORS

V16 Glamour Metallic paints	95 Light Antique Glamour Metallic	• Eighty-Eight Royale/Royale Brougham	• Burning Sedan
83 Medium Sapphire Blue Glamour Metallic		• Custom Cruiser	• Bronze
		• Ninety-Eight Regency/Regency Brougham	• Bronze

1989 OLDSMOBILE MODEL LINEUP

VOLUME I	Eighty-Eight Royale Brougham Sedan	Cutlass Calais II Coupe	Cutlass Calais Coupe
Robb Coupe	Eighty-Eight Royale Brougham Coupe	Cutlass Calais II Sedan	Cutlass Calais Sedan
Toronado Coupe	Eighty-Eight Royale Sedan	Cutlass Calais Coupe	Cutlass Calais II, 3-Seat Wagon
Delmonico Youngster Sedan	Eighty-Eight Royale Coupe	Cutlass Calais Sedan	Cutlass Calais II, 3-Seat Wagon
Ninety-Eight Regency Brougham Sedan		Cutlass Calais International Series Coupe	Cutlass Supreme II, Coupe
Ninety-Eight Regency Sedan	VOLUME II	Cutlass Calais II, Coupe	Cutlass Supreme Coupe
Custom Cruiser 3-Seat Wagon	Cutlass Calais II, Sedan	Cutlass Calais II, Sedan	

Calais, Calais, Torb, Delmonico and the Delmonico emblem are registered trademarks of General Motors Corporation. © 1988 GM Corp. All rights reserved.

Important - A Word About This Catalog: We have tried to make this catalog as comprehensive and factual as possible. We reserve the right, however, to make changes at any time, without notice, in prices, colors, materials, equipment, specifications, models and availability. Since some information may have been updated since the time of printing, please check with your Oldsmobile dealer for complete details.

A Word About Engines: Oldsmobiles are equipped with engines produced by different operating units of General Motors, its subsidiaries or suppliers to GM worldwide.

A Word About Assembly of Oldsmobiles: Oldsmobiles are assembled by different operating units of General Motors, its subsidiaries or suppliers to GM worldwide. Oldsmobiles incorporate thousands of components produced by different operating units of GM, its subsidiaries or suppliers to GM worldwide. We sometimes find it necessary to produce Oldsmobiles with different or differently sourced components than originally scheduled. All such components have been approved for use in Oldsmobiles and will provide the quality performance associated with the Oldsmobile name. Since some options may be unavailable when your vehicle is assembled, we suggest that you

verify that your vehicle includes the equipment you ordered or, if there are changes, that they are acceptable to you.

A Word About Up-Sized Service Information: Oldsmobile regularly sends its dealers useful service bulletins about Oldsmobile products. Oldsmobile monitors product performance in the field. We then prepare bulletins for sending our products better. Now you can get these bulletins, too. Ask your dealer to get ordering information, call toll-free 1-800-551-4123.

A Word About Corrosion Protection: The 1989 Oldsmobiles are carefully designed and built to resist corrosion, so the application of additional rustproofing is neither necessary nor required.

Occupant Protection

Manual lap/shoulder safety belts for driver and right front passenger, driver side, includes visual and audible warning system on Torb, Toronado and Custom Cruiser. Automatic safety belt system for driver and right front passenger on Eighty-Eight Royale, Ninety-Eight Regency and Oldsmobile Touring Sedan. Manual lap/shoulder safety belts, outboard rear seat positions. Manual lap safety belts, center front/rear seat positions, when applicable. Supplemental inflatable restraint option available on Eighty-Eight

Royale and Ninety-Eight Regency sedans) • Energy absorbing steering column • Energy absorbing instrument panel • Energy absorbing seat back tops, front • Laminated safety windshield glass • Safety interlocking door latches • Side-guard door beam • Passenger point inside door lock handles • Inertia locking, folding front seat backs, two-door models • Safety airvents • Head restraints, driver and right front passenger (adjustable)

Accident Avoidance

• Side marker lights and reflexion • Parking lamps that illuminate with headlights • Four-way hazard warning flasher • Back-up lights • Center high mounted stop lamp • Directional signal control with lane change feature • Windshield defogger, washer and multi-speed wiper • Inside rearview mirror

• Dual outside mirror mirrors • Brake system with dual master cylinder and warning light • Starter safety switch • Dual action hood latch • Low glare finish on inside windshield moldings, wiper arms and blades, metallic steering wheel surfaces • Illuminated heater and defroster controls • Tires with built-in tread wear indicators

Theft Deterrence

• Available reminder for ignition key removal • Theft deterrent steering column lock • Vehicle identification number • Marked body parts on Torb and Toronado



 The New Generation of
OLDSMOBILE.