

1 9 9 3

PLYMOUTH

ACCLAIM



PATTERSON - CHRYSLER - PLYMOUTH
JEEP - EAGLE
1965 N. Ellsworth Ave.
Salem, Ohio 44460
216-337-3475

DESIGNED
FOR THE
AMERICAN
FAMILY...
AFFORDABLE
AND
ROOMY



Some of the equipment shown or described throughout this catalog is available at extra cost.

About this catalog. Since the time of printing, some of the information you'll find in this catalog may have been updated. Ask your dealer for details.

ACCLAIM: FAMILY-SIZE COMFORT

If you're looking for a midsize sedan that's advanced in design and engineering and still offers the qualities and features American families want most, consider the 1993 Acclaim. It combines a stylish exterior with a spacious interior that fits the needs of a growing family. Add to these basics the special comfort of available six-passenger seating, plus a full complement of interior appointments and



Acclaim

conveniences. Acclaim also provides many important safety engineering advantages, such as a standard driver-side air bag and child-protection rear door locks, as well as optional four-wheel antilock disc brakes (see details on this page and on pages 3 and 11).

On the road, Acclaim is a happy marriage of a smooth, comfortable ride and front-wheel-drive stability. Handling is precise and agile. And you can call on the added performance of available V6 power. Acclaim keeps a grip on its reputation for quality and durability that stands up to the competition. Just one example: the new full stainless

steel exhaust system that resists corrosion. On the value side, Acclaim stands out from the crowd as one of the lowest-priced six-passenger cars in America. Offering over 50 standard features at a highly affordable price, the five- or six-passenger Acclaim may well be the smartest buy in a family sedan from America or Japan. **Advantage: Acclaim.**

SAFETY FIRST

■ Driver-Side Air Bag

Helps protect the driver from frontal impacts when used with three-point Unibelt restraints. Standard on Acclaim.

■ Four-Wheel Antilock Disc Brakes

Provides sure stopping power and improved steering control during hard braking and on slippery surfaces. Optional on Acclaim.

■ Side-Door Beams

Rugged, multiple steel beams are built into doors to provide extra protection for occupants in the event of side impacts.

■ Mopar Security Alarm System (EVS II)

Advanced electronic features of this completely automatic system offer increased theft protection. A dealer-installed option.

■ Energy-Absorbing Front and Rear Bumpers

To absorb front- and rear-end collision forces.

STIRRING PERFORMANCE

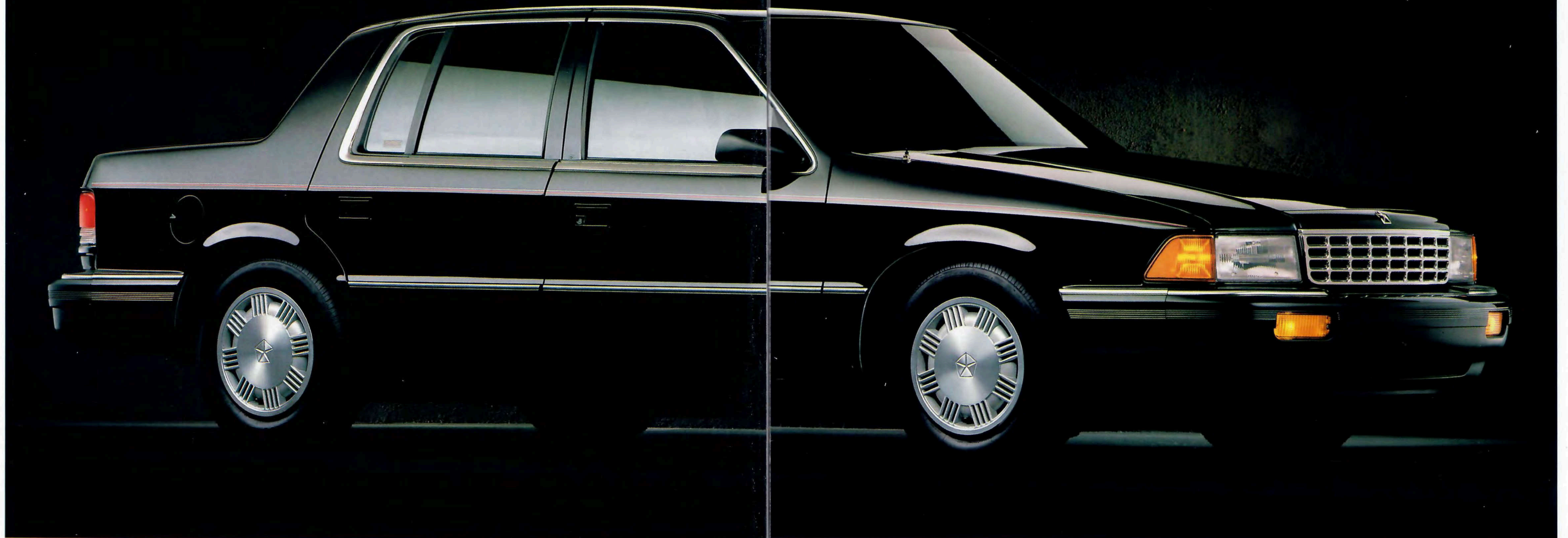

Simulated air bag deployment shown.

A built-in self-diagnostic feature constantly monitors the readiness of the air bag restraint system while you drive.



Three-point Unibelt restraint system includes standard lap-and-shoulder belts for outboard front- and rear-seat passengers.

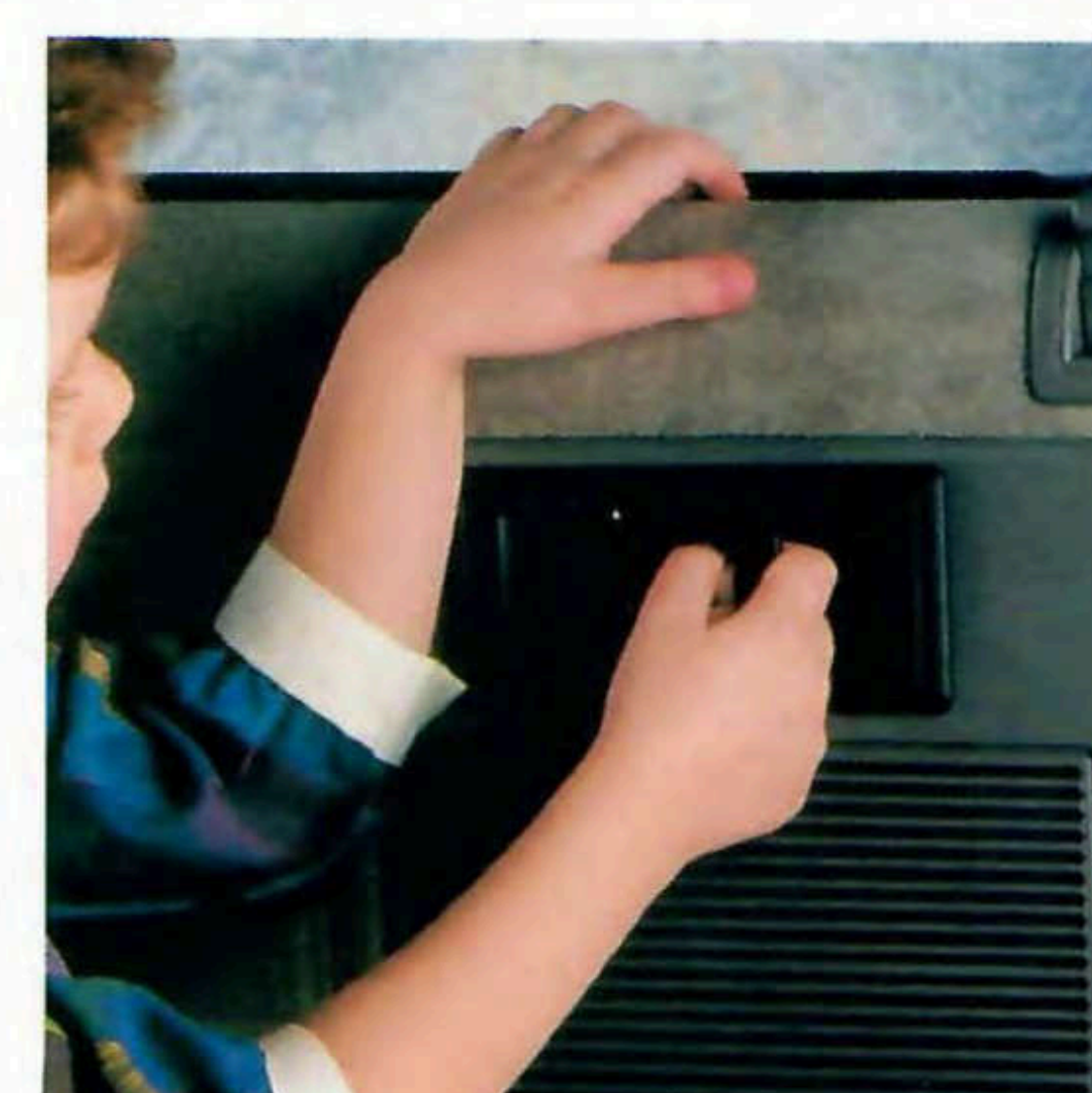

Standard child-protection rear door locks help keep kids safe by preventing accidental door opening from the inside.



*Plymouth engineers carried out extensive research followed by many hours of rigorous testing to meet customers' high expectations for quality, quietness, durability and reliability.**

**Simulated testing photo shown.*



Laser-guided "Mini Perceptron" machine vision system precisely measures body panel fit and finish tolerances to ensure quality.

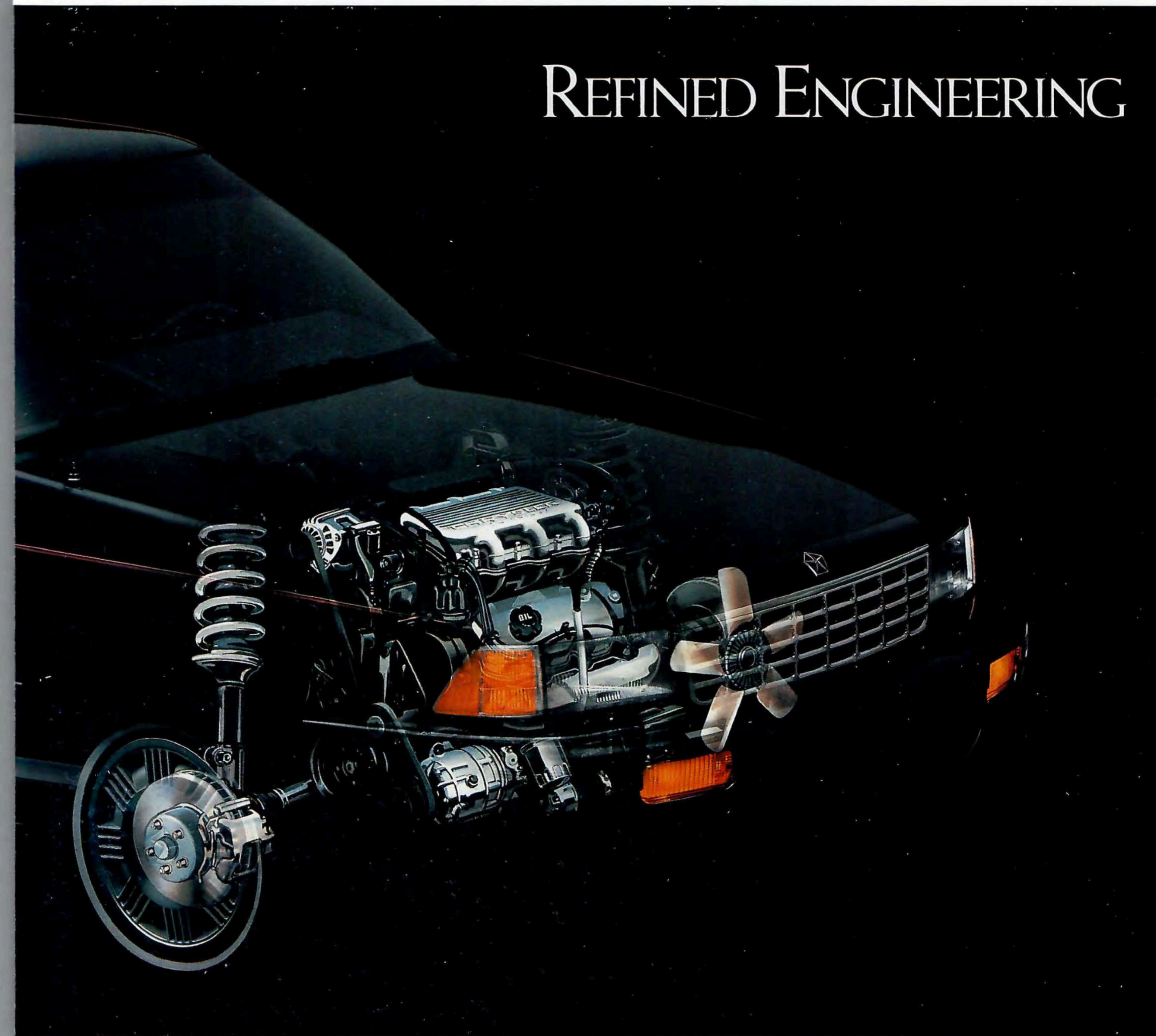

REFINED ENGINEERING

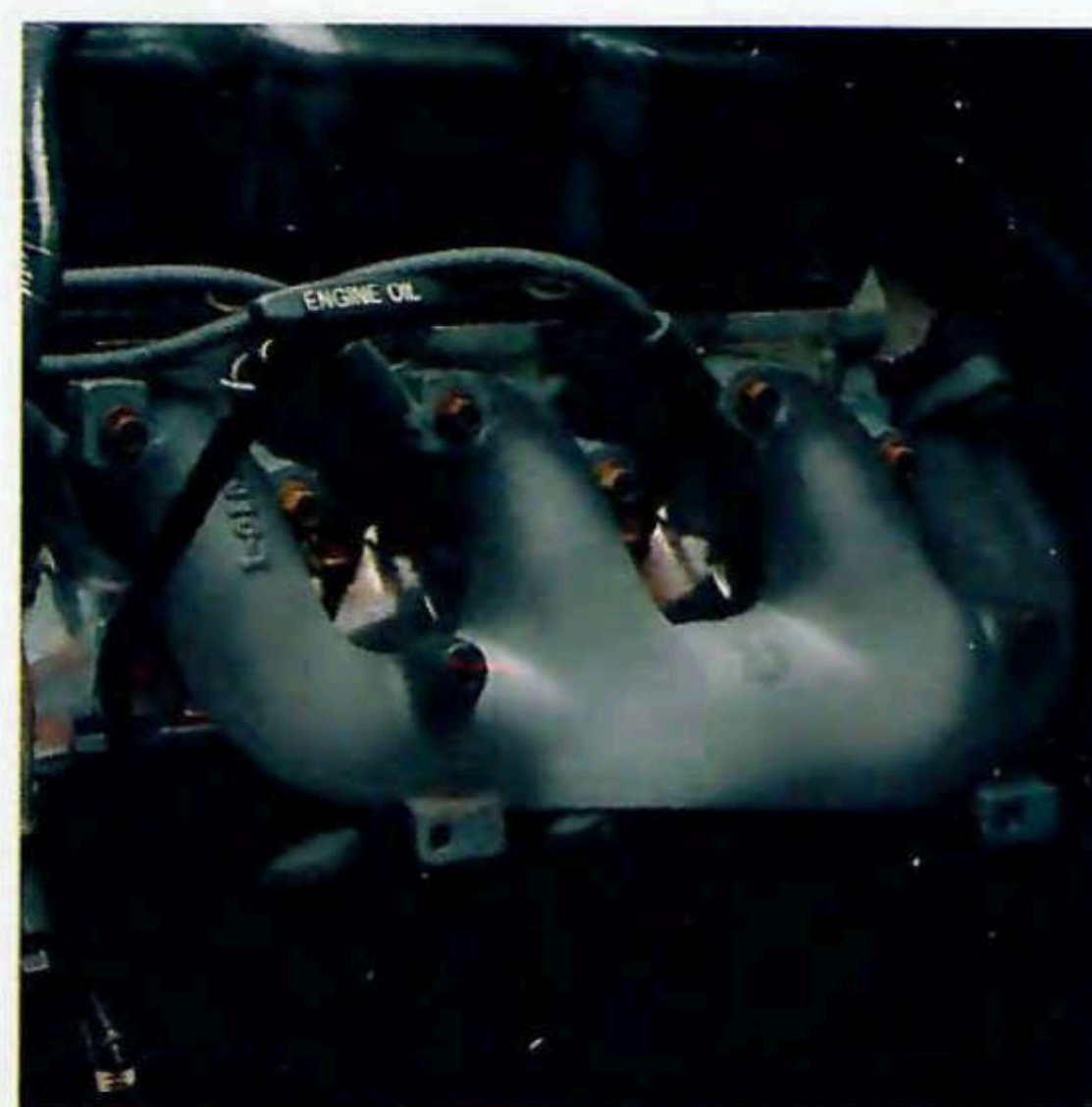

To ensure long life, test engines are subjected to punishing 800-hour endurance tests at up to 5,400 rpm.

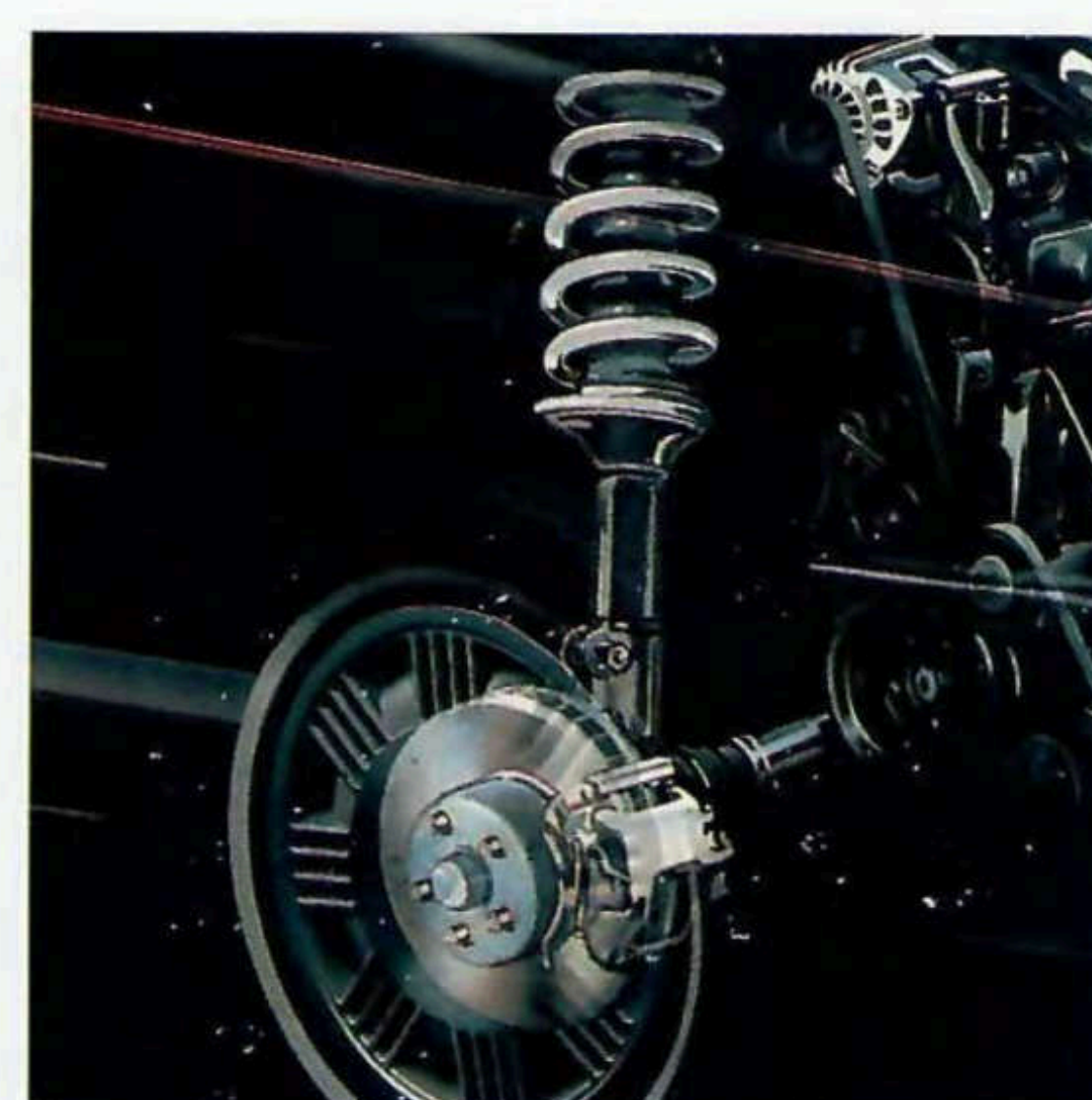

Acclaim's standard gas-charged front struts and gas-charged rear shock absorbers deliver a comfortable, controlled ride.

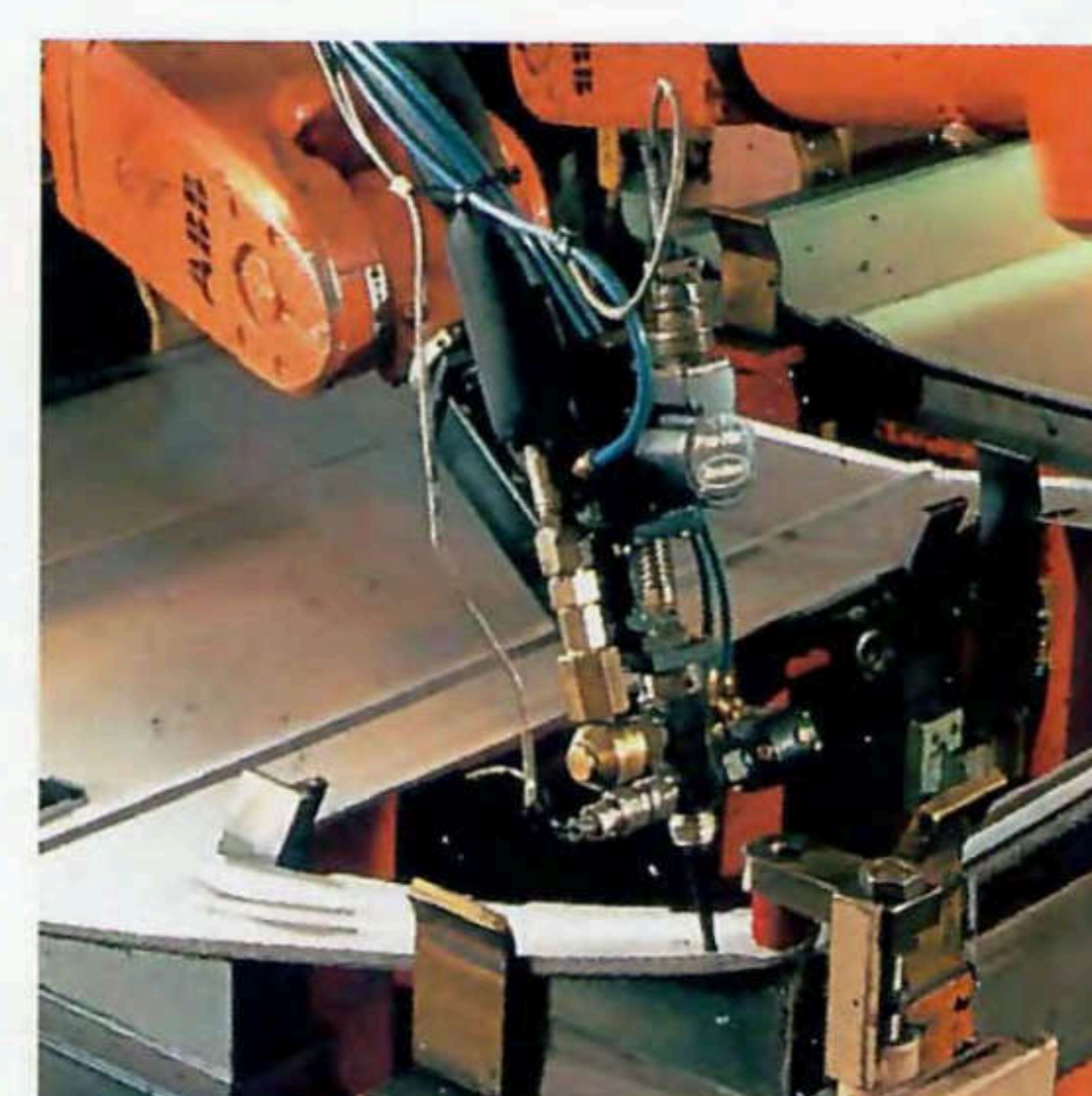

Epoxy-adhesive "anaerobic" bonding of the inner to outer door assembly means quietness and improved corrosion resistance.



An available 3.0-liter V6 SMPI (sequential multipoint fuel injection) engine is powerful, responsive and quiet running. A lively and efficient 2.5-liter EFI (electronic fuel injection) dual balance-shaft engine is standard on Acclaim. (See page 12 for complete engine details.)

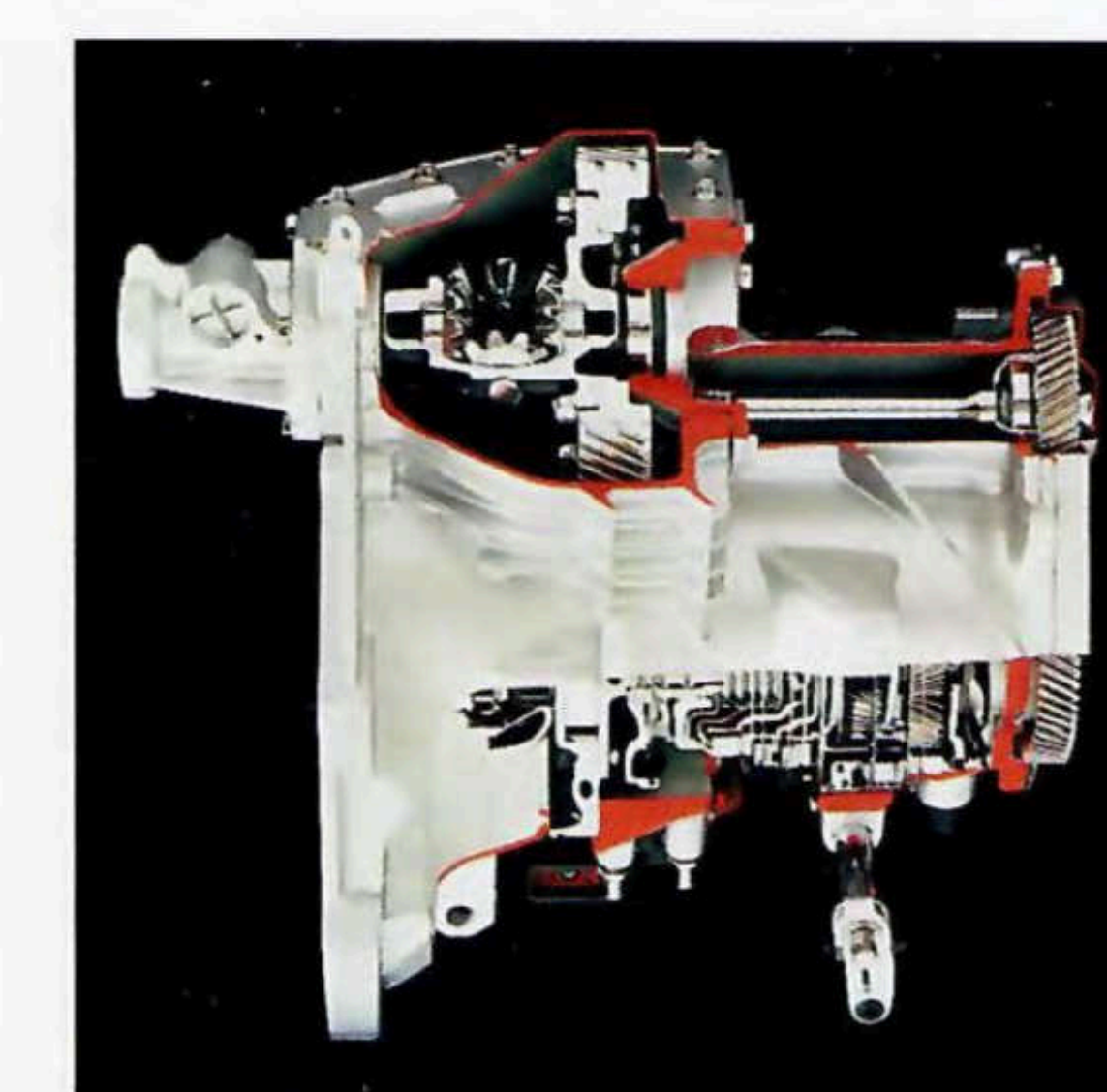

Optional computer-controlled four-speed automatic transaxle features new electronic modulation for smoother shifting.



Acclaim interior with available 50/50 split-bench front seat

SIX-PASSENGER COMFORT



Acclaim's instrument panel puts switches and controls within easy reach. Gauges are large and quick-reading. Convenient electronic speed control and tilt steering column are available, plus a newly designed AM stereo/FM stereo radio with cassette player or CD player and four Infinity speakers.*

**Some AM stereo broadcasting may not be compatible with this radio.*



Available split fold-down rear seatbacks are handy for carrying long cargo and lock to limit trunk access for secure storage.

Acclaim proves that it's every inch a family sedan. The roomy interior provides plenty of head room and over three feet of rear-seat leg room. Six people can ride comfortably in the optional 50/50 split-bench front seat and room-for-three rear seat.

The split-bench seat, standard

front bucket seats (shown right), and rear seat incorporate a new pattern which eliminates the seat seam for a more modern, smoother look. All seats are luxurious cloth with vinyl trim. A convenient full floor console with integral armrest is available as well as an illuminated entry system.



ENGINEERED SAFETY

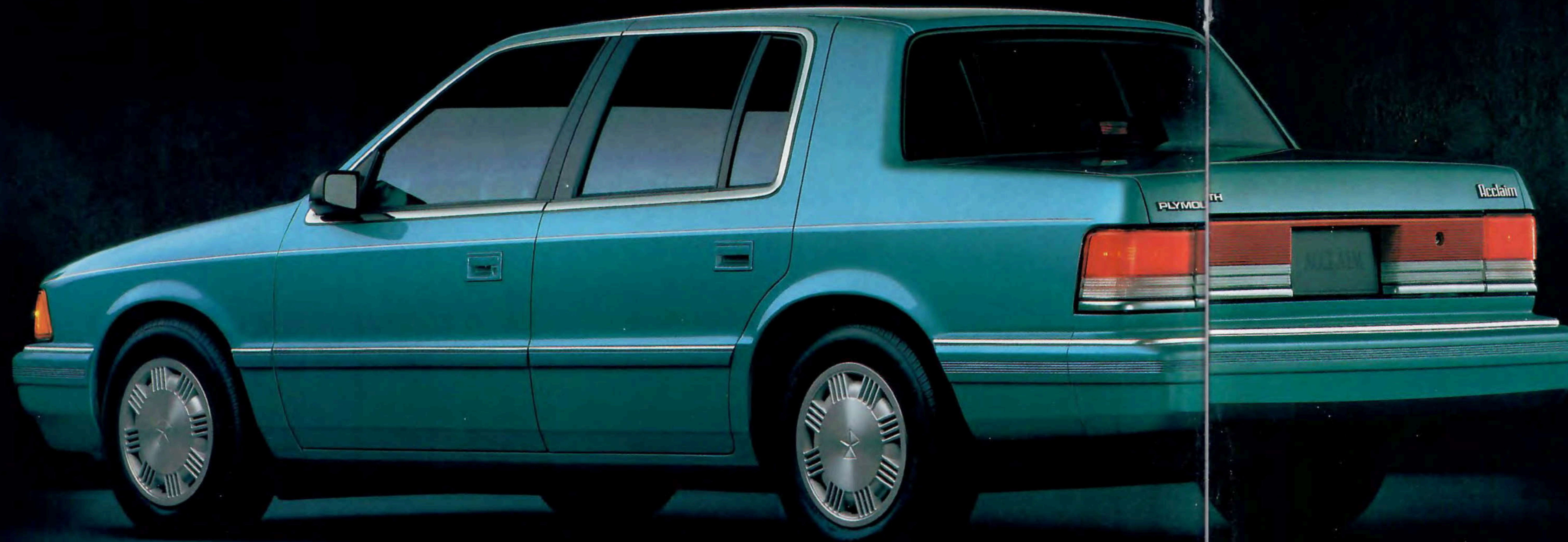

Acclaim puts a priority on the security of driver and passengers. The safety engineering advantages already described on pages 3 and 7 attest to that commitment. In addition to the driver-side air bag and three-point Unibelt restraint system, Acclaim offers: intermittent wind-

shield wipers, lockable glove box, key-left-in-ignition warning and the optional illuminated entry system that turns on the interior courtesy lights whenever either front door exterior handle is raised and released (with car doors locked); optional power door locks that let the driver lock

all doors from the driver's seat, the available electric rear window defroster* for improved rearward visibility in inclement weather, and more. Also, Acclaim beats the competition by offering the stopping ability of available four-wheel antilock disc brakes.

*Required on all passenger vehicles registered in New York State.



Low liftover trunk design permits easy, safe cargo loading. The spacious, carpeted trunk has 14.4 cubic feet of capacity.



Convenient Portable Cellular Phone weighs slightly over 13 ounces, complete with battery. A dealer-supplied option. (See page 15.)

QUALITY ASSURANCE

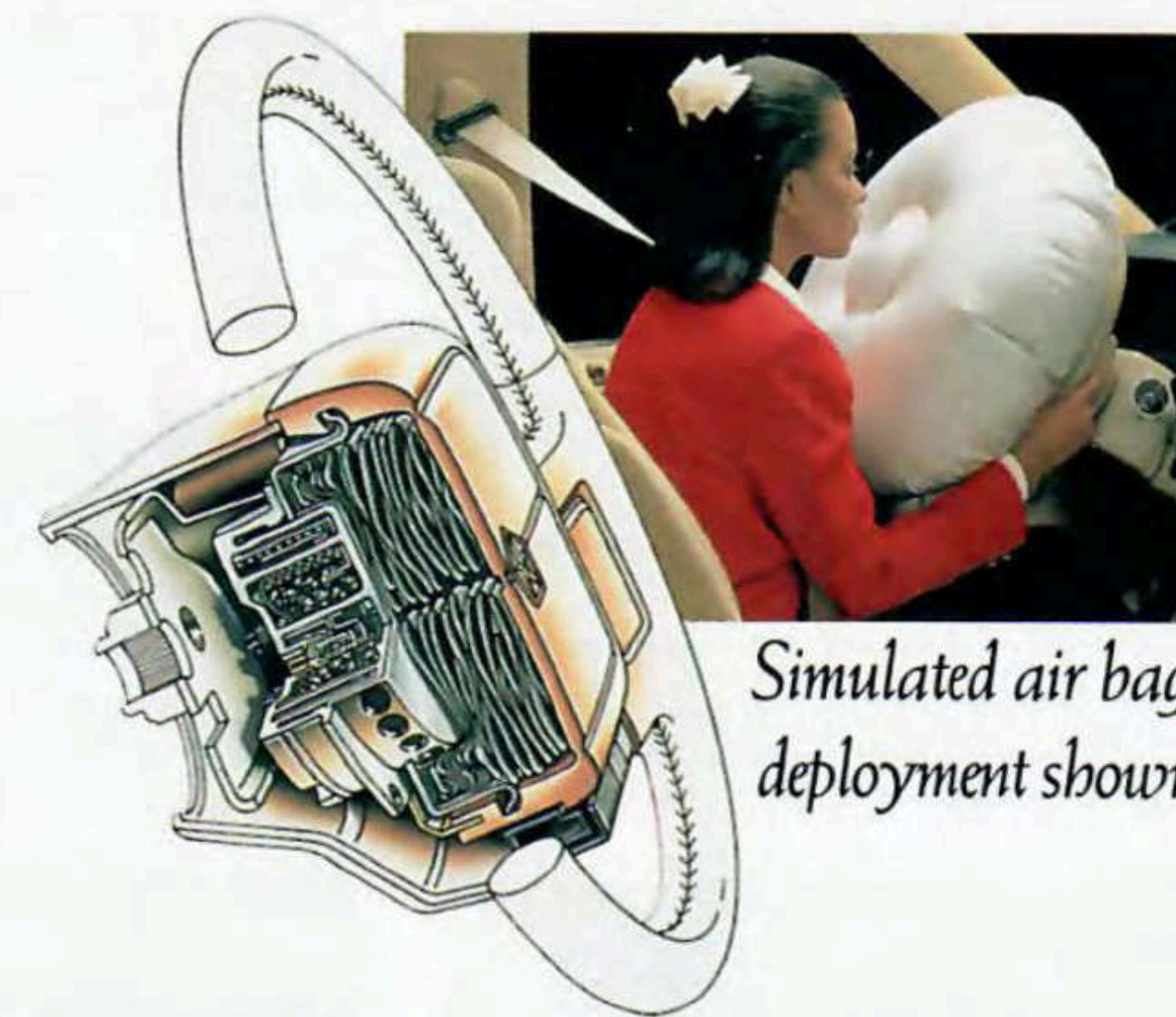

Simulated air bag deployment shown.

Driver-side air bag[†], standard, features impact sensors with gold electrical contacts for peak conductivity and reliability. Dual electronic control circuitry ensures air bag deployment even if one circuit fails. A microprocessor-driven, self-diagnostic system checks the circuits 30 times each second for maximum dependability.

[†]Supplemental restraint system.

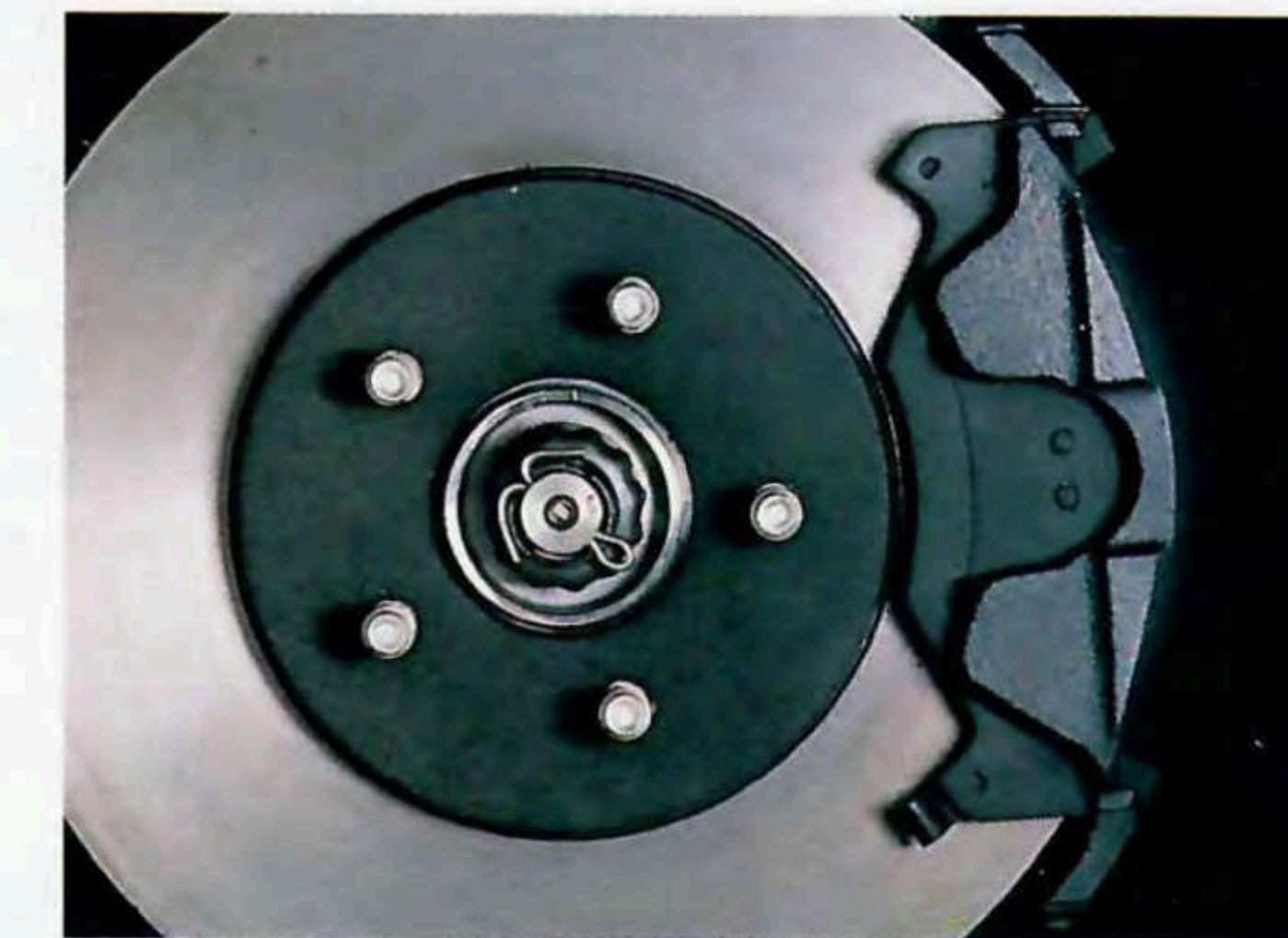

Optional four-wheel antilock disc brakes instantly detect brake lockup through wheel speed sensors and automatically "pump" braking pressure 15 times per second for maximum braking stability and safety. Chrysler antilock brake systems are tested and certified to the highest standard for optimum reliability.

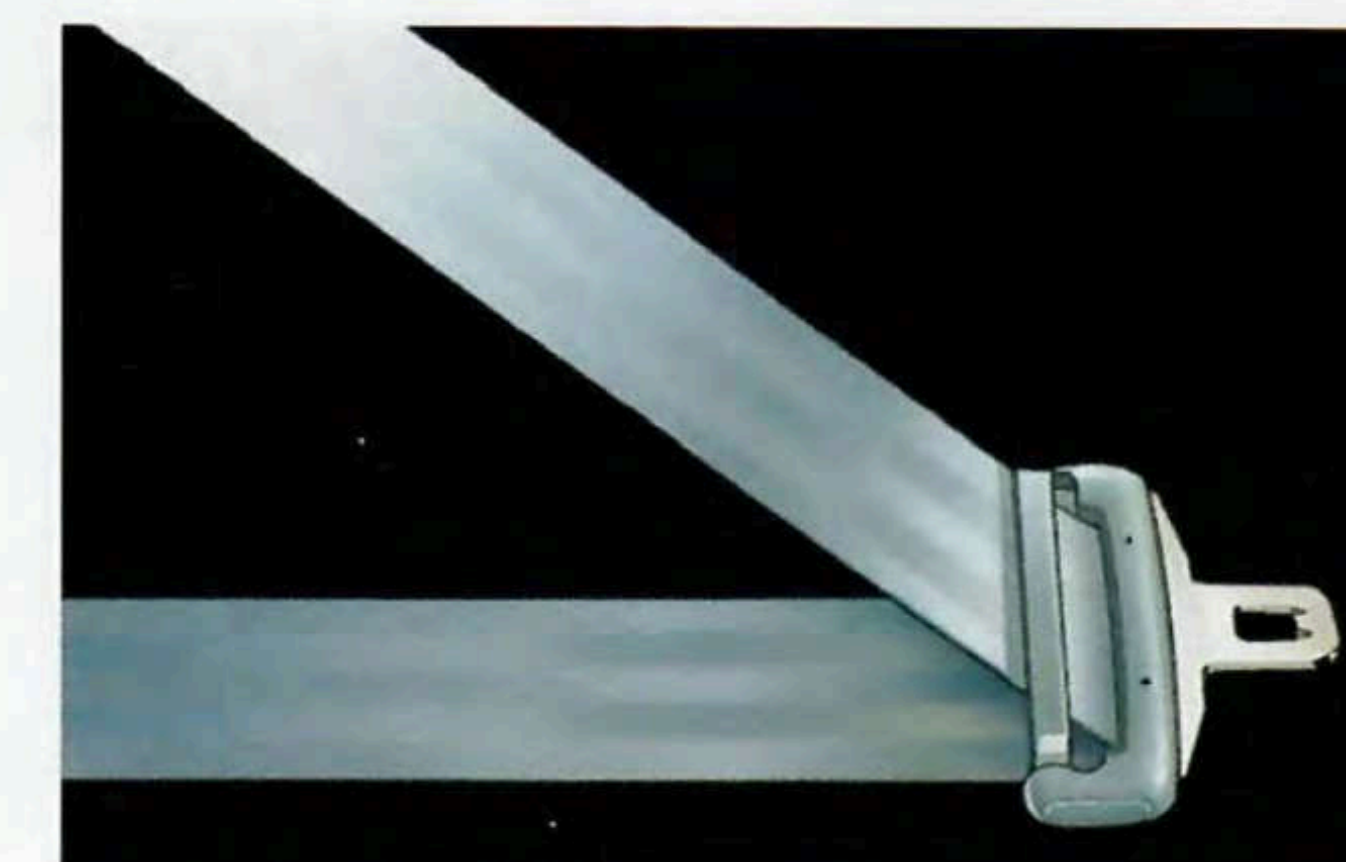

Unique cinching latchplate, used on Acclaim's front and rear three-point Unibelt restraint system, securely holds child seats or passengers in the right position for increased safety.

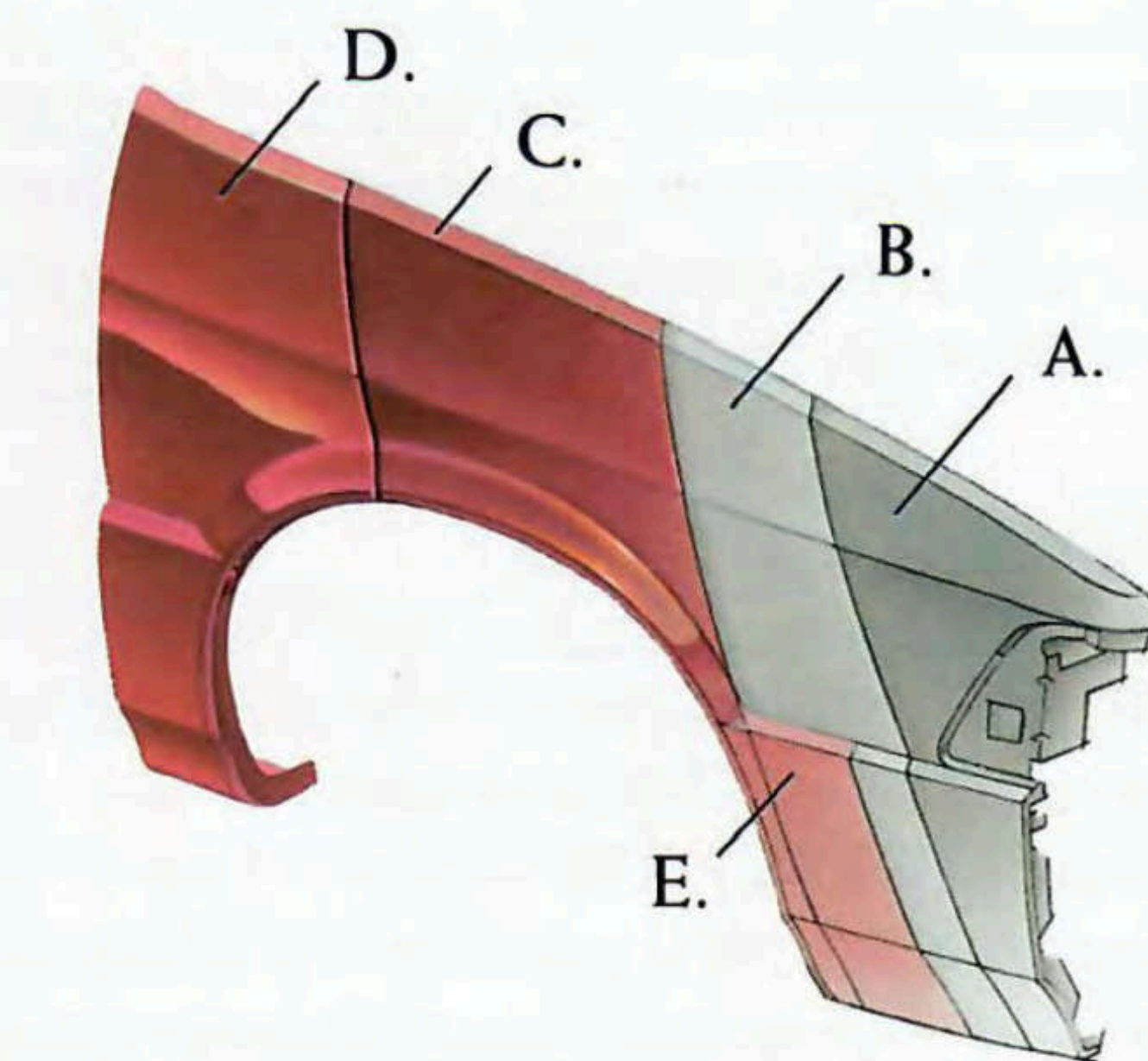

Comprehensive anticorrosion measures begin with extensive use of corrosion-fighting galvanized steel in body panels.

- A. Zinc-iron alloy-coated steel is zinc-phosphated as part of a nine-step pre-treatment which cleans and prepares the metal surface.
- B. The entire body is fully immersed in a coating of corrosion-resistant epoxy electrocoat primer.
- C. A two-stage base color coat is applied.
- D. Two coats of clear are applied wet-on-wet over the base coat for an environmentally resistant mirror finish. (All body panels exposed to corrosives, except roof, are two-side galvanized/galvannealed.)
- E. An antichip coating protects the lower bodyside against stone damage.



Mopar Diagnostic System enables Chrysler-Plymouth dealership technicians to use the latest computer-based diagnostic procedures to quickly and accurately service your vehicle.

ACCLAIM DIMENSIONS

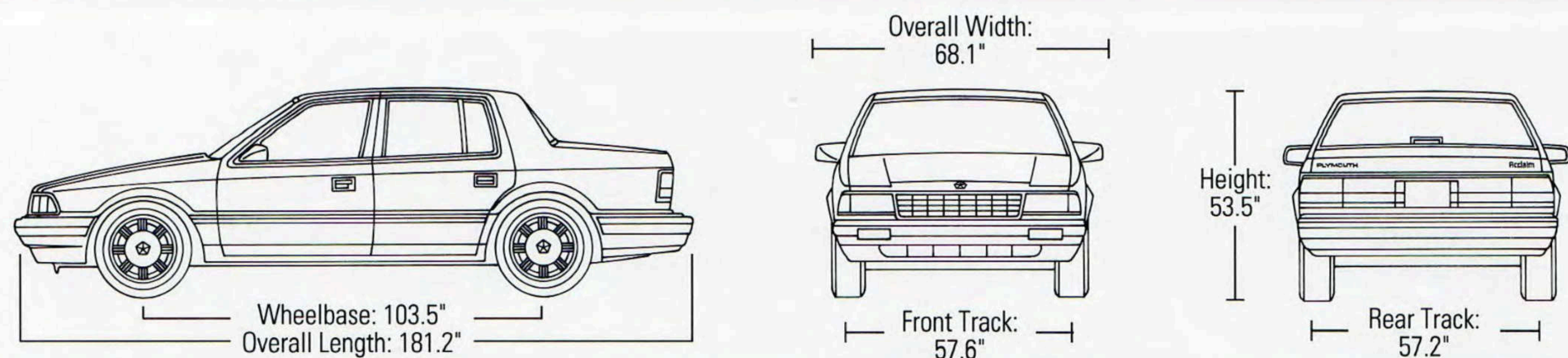

POWER TRAINS¹

2.5-LITER SOHC EFI DUAL BALANCE-SHAFT ENGINE

Acclaim's standard responsive 2.5-liter SOHC EFI four-cylinder engine includes electronic fuel injection (EFI) for optimal fuel metering and usage. The engine includes electronic ignition and voltage regulator, plus a smooth-running single overhead camshaft (SOHC), roller tappets, a torque rating of 135 lb-ft @ 2,800 rpm, and dual counterrotating balance shafts to help cancel vibration. Clutch/ignition safety interlock feature on five-speed transaxle permits engine starting only with clutch fully depressed.

3.0-LITER OHC V6 SMPI ENGINE*

This smooth, powerful 3.0-liter OHC V6 SMPI engine* is available on Acclaim with features such as overhead camshaft (OHC) and new sequential multipoint electronic fuel injection (SMPI). This engine develops a torque rating of 171 lb-ft @ 2,400 rpm. For maximum efficiency and performance, it's coupled with an optional electronically controlled four-speed overdrive automatic transaxle. (Three-speed automatic transaxle is available.) The safety interlock feature on either transaxle permits key removal only in "Park."

*Built by Mitsubishi Motors Corporation.

FLEXIBLE FUEL VEHICLE¹

Chrysler Corporation introduces flexible fuel vehicle technology on the 1993 Acclaim. This technical breakthrough gives you a choice of using unleaded gasoline, or any mixture of methanol fuel and unleaded gasoline, without sacrificing performance or drivability. Chrysler is at the forefront of this new technology that can help reduce the amount of ozone lost in the atmosphere and thereby help improve our environment and our nation's future energy security. Requires California Emissions Package.

ENGINE CHARACTERISTICS	2.5 LITER SOHC EFI DUAL BALANCE-SHAFT ENGINE	2.5 LITER MPI ¹ FLEXIBLE FUEL	3.0 LITER OHC V6 SMPI ENGINE ^{2,3}
TYPE	4-cylinder SOHC EFI	4-cylinder SOHC MPI	6-cylinder sequential multipoint EFI
DISPLACEMENT	2.5-liter (153 CID)	2.5-liter (153 CID)	3.0-liter (181.4 CID)
BORE & STROKE	3.44" x 4.09"	3.44" x 4.09"	3.59" x 2.99"
TRANSAXLE AVAILABILITY	5-speed close-ratio manual overdrive (2.66 OTGR): standard 3-speed automatic ² (3.02 OTGR): optional	3-speed automatic ²	4-speed automatic ² (2.49 OTGR): optional 3-speed automatic ² (2.78 OTGR): optional
COMPRESSION RATIO	8.9:1	8.9:1	8.9:1
HORSEPOWER/SAE NET @ RPM	100 hp @ 4,800	gas (unleaded): 97hp @ 4,800 M85:105hp @ 4,800	141 hp @ 5,000
TORQUE/SAE NET @ RPM	135 lb-ft @ 2,800	gas (unleaded): 135 lb-ft @ 2,400 M85:141hp @ 2,400	171 lb-ft @ 2,400

OTGR—Overall top gear ratio.
¹Emissions controls and testing required at extra cost on all vehicles registered in California. Not available otherwise.

²Includes electromechanical lockup torque converter.

³Includes P195/70R14 tires (set of four).

⁴Late availability in California. Requires California Emissions.

⁵Built by Mitsubishi Motors Corporation

DIMENSIONS

Head Room	Front.....38.4"	Rear.....37.9"
Leg Room	Front (max.).....41.9"	Rear (min.).....38.3"
Hip Room	Front.....51.7"	Rear.....52.0"
Shoulder Room	Front.....54.3"	Rear.....55.0"
Trunk Capacity (estimated)14.4 cu ft	
Turning Diameter—Curb-to-Curb (L/R)37.0/39.0	
Curb Weight with Standard Engine (estimated)2,778 lb	

TIRES

SIZE	TYPE (SET OF FOUR)	AVAILABILITY
P185/70R14	Steel-belted radial all-season touring tread design black sidewall low rolling resistance (set of four)	Standard
P195/70R14	Steel-belted radial all-season touring tread design black sidewall low rolling resistance (set of four)	Included with 3.0L V6 engine
P195/70R14	Steel-belted radial all-season touring tread design white sidewall low rolling resistance (set of four)	Optional
T125/70D14	Compact-type spare (one)	Standard
P185/70R14 P195/70R14	Matching-type; conventional-type spare (one)	Optional

MILEAGE*

25 EPA est. city mpg, 32 EPA est. hwy. mpg

*Mileage figures are for 1993 base Acclaim with standard engine and 5-speed manual overdrive transaxle.

TRAILER TOWING CAPACITY

ENGINE	TRANSAXLE	TOWING CAPACITY
2.5-liter four-cylinder	5-speed manual	1,000 lb
2.5-liter four-cylinder	3-speed automatic	2,000 lb
2.5-liter Flexible Fuel ⁴	3-speed automatic	2,000 lb
3.0-liter six-cylinder	4-speed automatic	2,000 lb

CUSTOMER-PREFERREDSM PACKAGES

ENGINES	TRANSAXLES	ACCLAIM			
		A	C	D	E
2.5L SOHC EFI	5-Speed Manual	A	C		
	3-Speed Automatic	A		D	E
2.5L MPI* Flexible Fuel	3-Speed Automatic	A		D	
3.0L SMPI V6	3-Speed Automatic			D	E
	4-Speed Electronic Automatic				E

PACKAGE CONTENTS				
Air Conditioning ¹		•	•	•
Deck Lid Release—Remote				•
Defroster ² —Rear window, electric		•	•	•
Mats—Floor: front and rear		•	•	•
Power Door Locks				•
Power Mirrors—Dual, heated				•
Power Windows				•
Radio—Four-speaker system		•	•	•
Speed Control—Electronic		•	•	•
Steering Column—Tilt		•	•	•

AVAILABLE OPTIONS				
Brakes—Four-wheel antilock disc ³	0	0	0	0
California Emissions	0	0	0	0
Console and Armrest Package (Requires bucket seats)			0	0
Defroster—Rear window, electric ²	0	P	P	P
Interior Illumination Package ⁴ —Includes illuminated entry, dual illuminated visor vanity mirrors, map, cigar lighter and underhood lights and message center				0
Power Door Locks		0	0	P
Radio—AM/FM stereo with cassette and clock		0	0	0
Radio—AM stereo ⁵ /FM stereo, with CD player, graphic equalizer, and four Infinity speakers				0
Seats—Cloth 50/50 front bench and split fold-down rear ⁶			0	0
Seats—Cloth front buckets and split fold-down rear ⁶			0	0
Seats—Cloth 50/50 front bench and fixed rear bench ⁷	0		0	0
Seat—Power, driver-side				0
Suspension—Touring		0	0	0
Tire—Conventional spare	0	0	0	0
Tire—P195/70R14, white sidewall			0	0

* Late availability in California. Requires California emissions controls testing at extra cost on all vehicles registered in California. Not available otherwise.
• = Included in package. 0 = Optional. Some items may also be available in Customer-PreferredSM Packages. See Customer-PreferredSM Packages and "Available Options" for availability. P=Package only. See Customer-PreferredSM Packages for availability.
¹ There are special engine cooling requirements for field-installed air conditioning. Failure to follow these requirements may invalidate warranty. See your dealer for details.

² Required on all passenger vehicles registered in New York State.

³ When ordering with a V6 engine, four-speed automatic transaxle is required.

⁴ Requires power door locks.

⁵ Some AM stereo broadcasting may not be compatible with this radio.

⁶ Includes premium sound insulation.

⁷ Available with column shift automatic transaxle only.

SAFETY FEATURES

- Air bag, driver-side
- Antitheft trunk lock
- Backup lights
- Brake fluid pressure loss warning light (also serves as parking brake indicator)
- Child-protection rear door locks
- Combination lap/shoulder belts for the driver, right front passenger, and outside rear passengers; lap belts for all others; includes provision for child seat tethers
- Double ball-joint rearview mirror mount
- Dual diagonal braking system with separate brake fluid reservoirs in the master cylinder
- Dual-note horn
- Electric windshield washers and wipers
- Energy-absorbing bumper system
- Energy-absorbing instrument panel and sun visors
- Fade-resistant front vented disc brakes
- Front seat head restraints
- Glare reduction measures for instrument panel, steering wheel, windshield wipers, windshield header and roof
- Hazard warning flasher system
- Headlight and wiper circuit breakers with automatic reset
- Ignition and steering column lock
- Impact-actuated fuel supply shutdown relay
- Inside and outside rearview mirrors
- Interlocking door latches
- Key-left-in-ignition warning
- Non-override door locks (except driver's door)
- Recessed inside door release handles
- Reinforced windshield header and roof
- Resilient window crank knobs
- Safety glass
- Safety-Rim wheels
- Seat belt reminder system
- Side door beams
- Side marker lights and/or reflectors
- Squeeze glove box latch
- Supplemental center high-mounted stoplight
- Turn signals with lane-change feature and flashing front side marker lights

FUNCTIONAL

Air Bag—Driver-side supplemental restraint system	S
Alternator—90-ampere	S
Antichip Protective Coating—Lower body	S
Battery—Heavy-duty, maintenance-free; with test indicator	S
Brake—Parking; foot-pedal-operated	S
Brakes—Dual diagonal, vented front disc, self-adjusting rear drum; power-assisted	S
Brakes—Four-wheel power-assisted disc with antilock feature (ABS)	O
Coolant Overflow Reservoir	S
Electronic Ignition, Voltage Regulator, and Fuel Injection	S
Emissions Controls and Testing—Required at extra cost on all vehicles registered in California; not available otherwise	O
Engine—2.5-liter SOHC EFI dual balance shaft	S
Engine—2.5-liter MPI* Flexible Fuel	O
Engine—3.0-liter OHC V6 SMP1	O
Exhaust System—Stainless steel	S
Front-Wheel Drive	S
Fuel Tank—16-gallon; with curbside fuel filler door	S
Jack—Scissors-type	S
Steering—Rack-and-pinion, fast-ratio (16:1), precision-feel; power-assisted	S
Suspension—Front gas-charged position-sensitive struts and solid antisway bar; rear beam axle with trailing arms, tubular antisway bar, and gas-charged shock absorbers	S
Suspension—Touring	O
Tire—Spare: compact, limited service, T125/70D14	S
Tire—Spare: conventional, P185/70R14 or P195/70R14	O
Tires—P185/70R14 steel-belted radial all-season touring tread design, black sidewall, low rolling resistance (set of four)	S
Tires—P195/70R14 steel-belted radial all-season touring tread design, black sidewall, low rolling resistance (set of four)	O ²
Tires—P195/70R14 steel-belted radial all-season touring tread design, white sidewall, low rolling resistance (set of four)	O
Transaxle—Five-speed close-ratio manual with overdrive	S
Transaxle—Three-speed automatic	O
Transaxle—Four-speed automatic computer-controlled	O
Wheel Covers—Deluxe: 14-inch (set of four)	S
EXTERIOR	
Bumpers—Energy-absorbing; color-keyed, with protective rub strips	S
Corrosion Protection—Extensive use of galvanized steel	S
Fuel Filler Cap Tether	S
Headlights—Halogen; aerostyle	S
Hood—Counterbalanced	S
Mirrors—Dual manual remote control; black	S
Mirrors—Dual power remote, heated	P
Moldings—Door center pillars (black); upper door frame and belt (bright/black); windshield and rear window (black)	S
Moldings—Bumper protective rub strip extensions, grooved body color with bright edge	S
Moldings—Narrow bodyside, body color with bright strip	S
Stripes—Bodyside; paint, two-color	S
INTERIOR	
Acoustical Package—Insulation: body sound	S
Acoustical Package—Premium: body sound ³	O
Air Conditioning ⁴ —Manual temperature control: with bi-level ventilation	P
Armrest—Center console-mounted: storage bin and dual cup holder for rear passengers included	O
Armrests—Door-mounted: two front, two rear	S
Ash Receivers—One front, two rear	S
Carpeting—Passenger compartment: color-keyed	S
Carpeting—Trunk floor and sidewall	S
Cellular Phone—Visorphone ⁵ ; dealer-installed ⁶	O
Cellular Phone—Mobile, dealer-installed ⁶	O
Cellular Phone—Portable, dealer-supplied ⁶	O
Chimes—Warning: fasten seat belt, headlights on, key in ignition	S
Cigar Lighter	S
Clock—Electronic digital (integral with radio)	S
Coat Hooks—Rear (two)	S
Console—Full floor; with cassette storage, storage bin and cup holders ⁷	S

Cubby Bin—Instrument panel; open; flocked	S
Deck Lid Release—Cable-operated remote control	P
Defroster—Rear window: electric (required on all passenger vehicles registered in New York State)	O
Demisters—Side window	S
Door Locks—Power	O
Door Release Handles—Interior: easy-open, with plunger type lock/unlock system	S
Floor Mats—Front and rear: carpeted	P
Glass—Tinted, all windows	S
Glove Box—Lockable; includes storage for cassette tapes	S
Head Restraints—Front: two-way adjustable	S
Heater and Defroster—With bi-level ventilation and side window demisters	S
Hood Release—Inside	S
Horn—Dual-note	S
Instrument Cluster—Electromechanical analog speedometer with secondary metric scale; odometer, trip odometer; gauges for electrical system voltage, engine coolant temperature, and fuel level; warning lights for brake system failure or parking brake on, check engine, check gauges, fasten seat belts, low fuel, low oil pressure, air bag, and ABS warning (if equipped)	S
Keys—Reversible: double-bitted, with valet feature	S
Lights—Ash receiver, dome, front and rear door switches for dome light, glove box, trunk	S
Light Package—Cigar lighter, map light, underhood, illuminated entry, dual illuminated vanity mirrors	P ⁷
Locks—Interior rear doors: child-protection	S
Message Center—Graphic: includes warning lights for door ajar, headlight out, low windshield washer fluid, stoplight out, taillight out, deck lid ajar	P ⁸
Mirror—Rearview day/night	S
Mirrors—Dual visor vanity; driver-side, covered	S
Multifunction Control Lever—Mounted on steering column: includes controls for turn signals with lane-change feature, headlight dimmer, and day/night flash/pass feature; windshield wiper/washer, pulse-wipe feature	S
Radio—AM/FM stereo: electronically tuned; Dynamic Noise Reduction ⁹ ; two front speakers, integral digital clock	S
Radio—AM/FM stereo: electronically tuned; Dynamic Noise Reduction ⁹ ; cassette tape player with automatic reverse; integral digital clock; four speakers	O
Radio—Four-speaker system	P
Radio—AM stereo ¹⁰ /FM stereo, premium CD, Dynamic Noise Reduction ⁹ and Infinity Sound System, integral digital clock	O
Seat Belts—Three-point Unibelt, with automatic retractor and child-resistant cinching latchplate on front and rear outboard seats, lap belts at all other positions: color-keyed	S
Seats—Front: cloth with vinyl trim low-back bucket with reclining seatbacks and two-way adjustable head restraints	S
Seats—Front: cloth with vinyl trim 50/50 split bench	O
Seats—Power, left side of 50/50 split bench or driver-side bucket	O
Seats—Rear: cloth with vinyl trim bench	S
Seats—Rear: cloth with vinyl trim folding seatback, split 55/45; lockable latches	O
Speed Control—Electronic	P
Steering Column—Tilt	P
Steering Wheel—Luxury with air bag	S
Supplemental Stoplight—Center high-mounted	S
Visors—Dual	S
Windows—Power	P
Windshield Wipers—Deluxe; with variable intermittent wipe feature	S

S= Standard. P= Included in Customer-PreferredTM Package listed above. O= Optional. Available only when corresponding Customer-PreferredTM Package is ordered.
¹Late availability in California. California emissions testing required.
²Built by Mitsubishi Motors Corporation.
³Included with 3.0L V6 engine.
⁴Included with 55/45 split-folding rear seat.
⁵There are special engine cooling requirements for field-installed air conditioning. Failure to follow these requirements may invalidate warranty. See your dealer for details.
⁶OKI[®] Telecom manufactures, services and is the warrantor of cellular phone systems available on selected Chrysler Corporation vehicles. Visorphone is a registered trademark of Cartell, Inc.
⁷Panasonic is the warrantor and services this product. Restrictions apply. Ask your dealership for details and a copy of the limited warranty.
⁸Requires bucket seats and manual transaxle.
⁹Part of Interior Illumination Package.
¹⁰Dynamic Noise Reduction is a trademark of National Semiconductor Corporation.
¹¹Some AM stereo broadcasting may not be compatible with this radio.

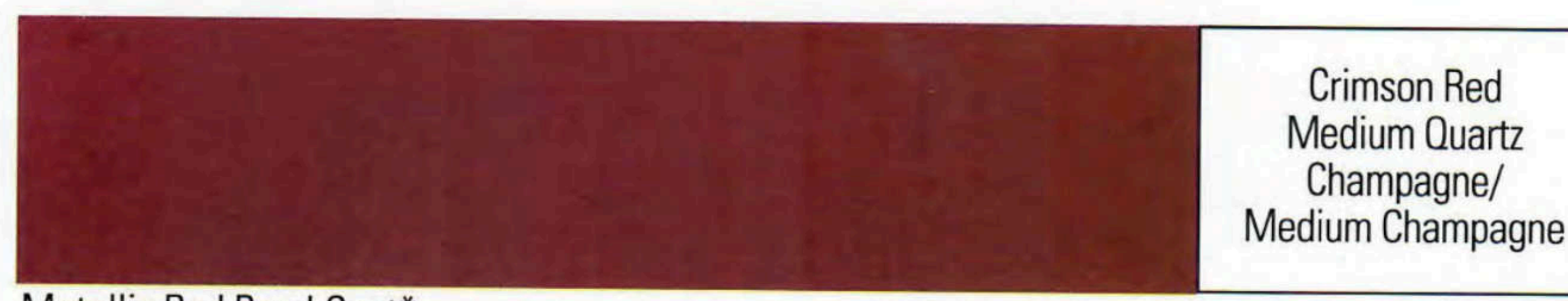

Metallic Red Pearl Coat*

Crimson Red
Medium Quartz
Champagne/
Medium Champagne



Wildberry Pearl Coat

Crimson Red
Champagne/
Medium Champagne



Light Driftwood Satin Glow*

Medium Quartz
Champagne/
Medium Champagne

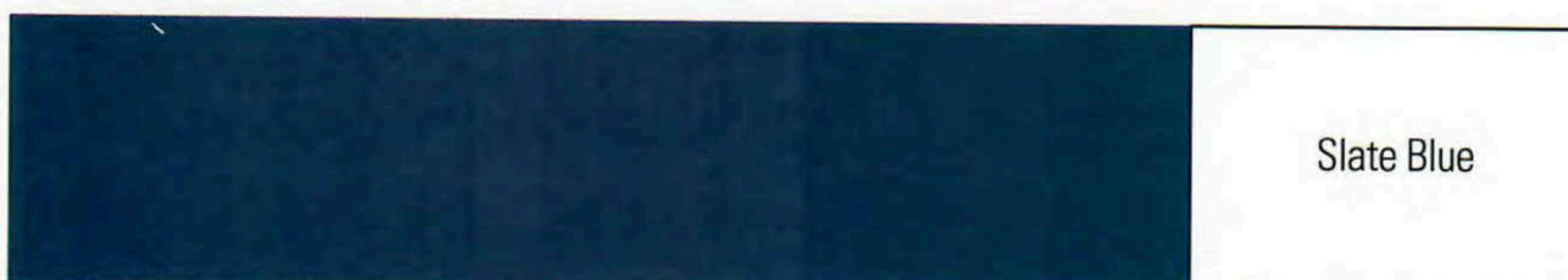

Sapphire Blue Satin Glow*

Slate Blue



Light Blue Satin Glow

Slate Blue



Aqua Pearl Coat

Medium Quartz



Emerald Green Pearl Coat

Medium Quartz
Champagne/
Medium Champagne



Bright White Clear Coat

Crimson Red
Slate Blue
Champagne/
Medium Champagne
Medium Quartz



Black Clear Coat

Crimson Red
Champagne/
Medium Champagne
Medium Quartz

*Extra cost.
All exterior colors have a Clear Coat finish.
Note: Due to printing limitations, the colors shown will vary slightly from actual hues.
See your dealer for accurate color chips.



The Owner's Choice Protection Plan
Now you have a choice of protection plans to suit your needs. When you purchase a new 1993 Plymouth Acclaim you can choose either of the two limited warranty plans described below.

3/36 Bumper-To-Bumper Limited Warranty The three-year or 36,000-mile Basic Bumper-to-Bumper Limited Warranty covers the entire vehicle including power train (excludes adjustments, tires, normal wear items and maintenance). No deductible applies. Restrictions apply. See your dealer for a copy of this limited warranty.

OR: 7/70 Power Train Limited Warranty Upon expiration of the 12-month or 12,000-mile Basic Limited Warranty, coverage is extended on power train components to seven years or 70,000 miles. No deductible applies. Restrictions apply. See your dealer for a copy of these limited warranties.

7/100,000 Anticorrosion Limited Warranty In addition, all Chrysler Corporation vehicles are covered by the 7/100,000 Outer Panel Anticorrosion Limited Warranty. Your dealer will repair or replace at no charge outer body sheet metal panels found to have developed perforation (rust-through) in normal use up to seven years or 100,000 miles. No deductible applies. See your dealer for a copy of the warranty.



We sell satisfaction. Additional peace-of-mind protection for vehicle owners is available through optional Chrysler Service Contracts. These services are available in a variety of time and mileage combinations to meet your particular driving needs.



Chrysler Credit Financing Chrysler Credit offers a variety of finance programs that can help make your new Plymouth Acclaim even more affordable. These flexible finance and lease programs can be tailored to suit your budget and your lifestyle. They include Gold Key Plus, College Graduate Plans, Gold Key Lease, Retail Financing and other special payment plans. Ask your salesperson for details.



Mopar MOPAR parts are engineered by Chrysler Corporation for use in your new Plymouth Acclaim. When replacement is necessary, be sure to specify MOPAR parts. Used by professional automotive technicians worldwide.

Mopar Accessories Here is a list of the more popular Mopar accessories available for Plymouth Acclaim. See your dealer for a complete list and availability by model.

- Electronic Vehicle II System/Keyless Entry
- CD Player
- CD Changer
- Ski Carrier/Bike Carrier
- Deck Lid Luggage Rack



Chrysler Cellular Systems For 1993, Chrysler will be offering a selection of dealer-installed/supplied cellular phones in several models to enhance the available optional equipment list. Ask your dealer for details. OKI[®] and Panasonic warrant and service these products. Restrictions apply. Ask your dealer for details and a copy of these limited warranties.



Physically Challenged Assistance Program Cash reimbursement of up to \$500 for purchase and installation of adaptive driving aids or passenger equipment on new 1993 Chrysler Corporation cars, trucks or vans. For further information, contact your dealer or the PHYSICALLY CHALLENGED RESOURCE CENTER at 1-800-255-9877.

All product illustrations and specifications are based upon current information at the time of publication approval. Although descriptions are believed correct, complete accuracy cannot be guaranteed. Chrysler Corporation reserves the right to make changes from time to time, without notice or obligation, in prices, specifications, colors and materials, and to change or discontinue models. See your dealer for the latest information.

Plymouth and MOPAR are registered trademarks, and Acclaim is a trademark of Chrysler Corporation.

Buckle up for safety.

 **ADVANTAGE: ACCLAIM**
A DIVISION OF THE CHRYSLER CORPORATION

