

BONNEVILLE

97 PONTIAC





Bonneville houses Pontiac's most advanced engineering in a thoroughly modern design that pleases both the wind and eye. This is the Bonneville SSEi in Silver-Taupe Metallic shown with available sunroof.

In the Pontiac tradition, Bonneville is first and foremost one of the world's finest sport sedans: meaning it understands the synergy between road and car, and car and driver. In the purest sense, these are the only relationships that matter. The resulting high-performance sport sedan provides drivers with a personal driving experience free of the bulk and pretense often associated with contemporary luxury cars. In contrast to the isolation others offer, Bonneville counters with involvement and total control of the driving environment. A rolling testament to luxury redefined, Bonneville confidently enters 1997 as Pontiac's flagship. ■



*Design melds with function:
Note how designers crafted
Bonneville's dramatic
taillamps to mimic the form
of the aerodynamic headlamp
lens (shown on overleaf).*



*While Bonneville's surfaces
fluidly meld, the surfaces
themselves are an amalga-
mation of highly durable
galvanized steels, dent-
resistant polycarbonates
and flexible polymers.*

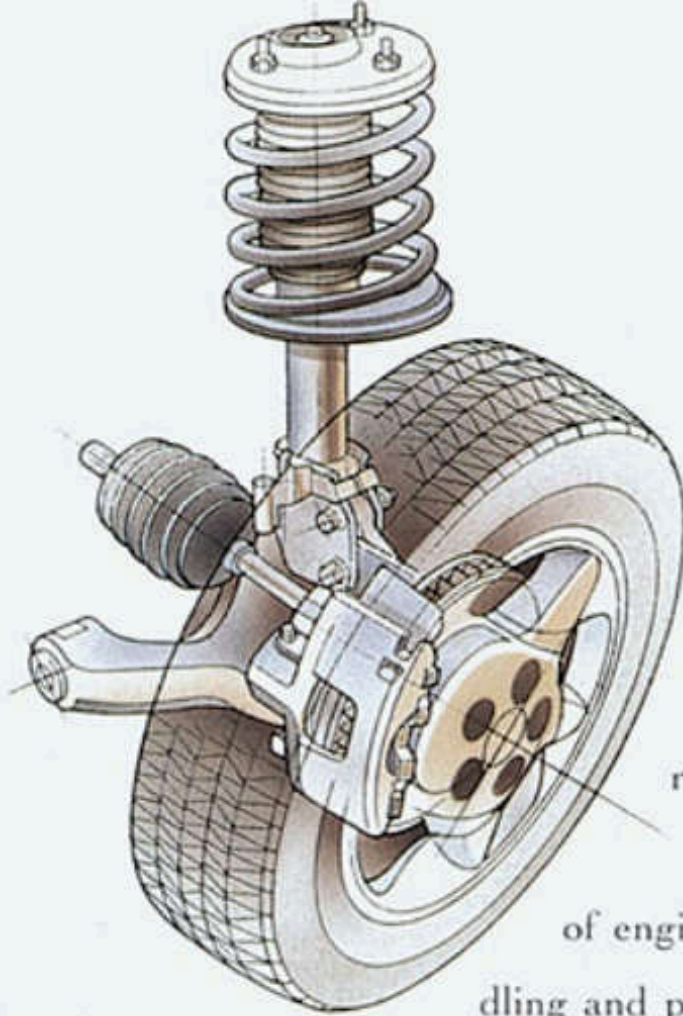

The SSEi's chassis features a fully independent suspension, electronic load leveling, Magnasteer variable-effort power steering and a four-wheel anti-lock braking system. The sophisticated Computer Command Ride adjustable suspension is available.

It is a rare sedan that demonstrates a clear commitment to pure performance. From the first Bonnevilles that set speed records on the salt flats of Utah to this present SSEi, Bonneville remains true to its reason for being.

Demonstrable proof presents itself in the form of engineering that delivers exceptional control, handling and power. The SSEi's noteworthy capabilities make the car stand out as one of the world's most powerful sport sedans—no surprise given the Eaton supercharger fixed atop the SSEi's award-winning engine. The features that enable this commanding performance similarly enhance Bonneville's premium level of comfort.



Remarkably refined and quiet, the Supercharged Series II 3800 V6 propels the SSEi with 240 horsepower at 5200 rpm and an enormous 280 ft-lbs of torque at only 3200 rpm.



Fingertip controls modify the SSEi's transmission shift characteristics, as well as the settings for the Traction Control and available Computer Command Ride.

Fast-paced roads separate the genuine road cars from the pretenders. Roads like these demand what the SSEi provides. Shown at right is the Bonneville SSEi with available SSEi Supercharger Package in Silver-Taupe Metallic.



Bonneville SE with Sport Luxury Edition Package in Dark Green Metallic with 16" 5-spoke wheels.





For drivers who prefer to be involved in their driving experience, Bonneville's crafted interior provides all that's necessary.

Bonneville interior shown in Taupe (photo shown includes extra-cost options).



Instrumentation provides the window through which vital information reaches the driver. Like any good window, the view is clear. At night, Pontiac's hallmark of red backlighting ensures exceptional visibility.



The reason Pontiac offers the Sport Luxury Edition with either 205 or 240 horsepower (with the available supercharged engine) stems from the fact that different drivers demand differing amounts of reserve power.

Bonneville with the Sport Luxury Edition Package: From the moment the doors remotely unlock, it becomes amply clear that the luxury of Bonneville centers on the driver. Interior lights illuminate to give the driver time to acclimate to the purposeful driving environment. The contoured leather driver's seating area includes power adjustments. Interior temperatures adjust automatically, as does the level of assist provided by the sophisticated variable-effort rack-and-pinion power steering system (adding steering assist to make parking easier, and reducing assist to provide necessary road feel at highway speeds). Music comes to life through the six-speaker, AM/FM cassette audio system, while the job of bringing the road to life is assigned to the low-profile Goodyear Eagle LS touring tires and the quicker 3.06:1 performance axle ratio. Bonneville: Everything is under control—the automobile over the environment and the driver over the road.

With an interior as quiet as the Bonneville's, the rich sound produced by the available CD player is heard with fidelity. Sound system controls on the steering wheel are also available.





Bonneville SE in Medium Dark Teal Metallic with available 16" Crosslace wheels.



The Bonneville SE uses a three-channel, electronically controlled anti-lock braking system as one way to enhance braking and steering control in otherwise unpredictable situations (such as steering around an obstacle while braking on slick pavement).

Sport sedans earn their stature by endowing drivers with the ability to control. Bonneville SE excels by indulging drivers with the requisite road-going hardware: a 205-horsepower V6, electronically controlled four-speed automatic transmission and a taut, fully independent suspension.

Beyond these performance-oriented basics, Bonneville furnishes drivers with expected standards such as air conditioning, power windows, power door locks, and welcome extras such as the convenience of the rear-seat pass-through and cruise control. Welcome personal security comes from an integrated theft-deterrent system, all-season touring tires and a fully automatic lighting system featuring daytime running lamps. Considering all it apportions to drivers to excite the driving experience, Bonneville earns its status as one of the world's finest sport sedans.

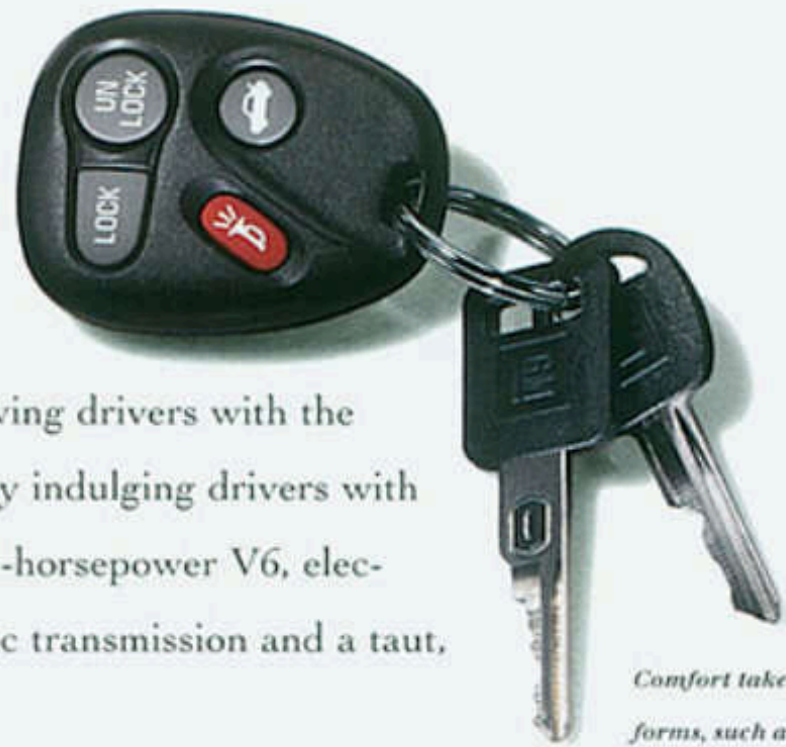

Comfort takes on many forms, such as knowing that every Bonneville features the security afforded by the PASS-Key II theft-deterrent system. Personal security is further enhanced with the available remote keyless entry, providing the ability to lock or unlock the doors from up to 30 feet away.



Unmistakable and brilliant, Bonneville looks as distinctive at night as it does in the day.

Day or night, close to home or in a distant city, Bonneville owners drive with the assurance of Pontiac Cares. Services to help drivers when they are locked out, out of fuel, have a flat tire or dead battery are only a toll-free call away. (Photos shown include extra-cost options.)



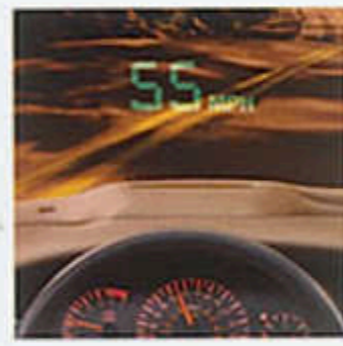

Aeronautical technology aided in the design of the available second-generation EyeCue Head-Up Display (SSE only). It projects selected vital data onto the windshield for easier viewing.



Already equipped with daytime running lamps, Bonneville's standard Twilight Sentinel knows when it's time to turn on the full headlamp system.



Bonneville SSE's interior shown in Taupe (photo shown includes extra-cost options).



Inside Bonneville, there is no coach class. In addition to generous amounts of room, rear-seat riders benefit from their own vent outlets.



The SSE's available 12-way articulating bucket seats provide a virtually limitless range of adjustments for excellent comfort and support.



When inclement weather heightens concerns about driving, Bonneville provides the means to help remain in control and confident: front-wheel-drive traction, anti-lock brakes and available Traction Control.

All about Bonneville

PONTIAC CARES



Pontiac backs every 1997 Bonneville with the following services:	SE	SSE
Extensive 3-year/36,000-mile bumper-to-bumper limited warranty	S	S
24-hour Roadside Assistance that provides in an emergency:		
Free lockout assistance	S	S
Free dead-battery assistance	S	S
Free out-of-fuel assistance	S	S
Free flat-tire change	S	S
Free towing for warranty repairs	S	S
Courtesy Transportation	S	S

EXTERIOR FEATURES

Sport Luxury Edition (SLE) (H4U): Includes 16" 5-spoke aluminum wheels, P225/60R16 touring tires, 45/45 bucket seats, leather seating areas, floor console, leather-wrapped steering wheel and shifter knobs, power antenna, 6-speaker sound system, rear deck lid spoiler and 3.06 axle ratio (requires LSD option group)	A	-
Antenna: Fixed mast (black)	S	-
Power mast (chrome)	A	S
Daytime running lamps with Twilight Sentinel	S	S
Fog lamps	S	S
Glass, Soft-Ray tinted	S	S
Headlamps, halogen clear lens with reflector optics	S	S
Mirrors: Sport, LH remote, RH manual	S	-
Sport, LH and RH power remote	A*	-
Heated with blue tint, power	-	S
Moldings: Wide bodyside and rocker moldings, monotone	S	-
Ribbed, aggressive monotone bodyside applique and rocker moldings	-	S
Monotone ground effects package	-	S
Spoiler: Rear deck lid	A	S
Spoiler delete	A**	A
Tires (steel-belted radial): P215/65R15 blackwall, touring (QP1)	S	-
P225/60R16 blackwall Eagle LS, touring (QNX)	A	S
P225/60HR16 blackwall Eagle RSA, speed-rated (QVG) (standard with WA6 supercharged 3800 engine; requires Computer Command Ride and L67 supercharged 3800 engine on SLE)	A**	A
Compact spare	S	S
Wheels/Wheel Covers:		



A



B



C



D



E

A Bolt-on wheel covers, 15" (PG1)	S	-
B 16" Crosslace cast aluminum machine-faced (PA2) or gold (N73)	A	A
C 16" cast aluminum 5-blade, silver (PF5)	A	A
D 16" cast aluminum Torque Star in Bright Chrome (PO5)	A	A
E 16" cast aluminum 3-spoke, silver (PA6)	-	S

*Available in Option Group only. **Available with SLE only.

INTERIOR FEATURES

	SE	SSE
Accessory emergency road kit	A*	S
Air bags/safety belts: Driver and front passenger**	S	S
Safety belts, 3-point active, height adjustable (outboard)	S	S
Air conditioning: Manual	S	-
Automatic with outside air temperature indicator	A†	S
Console, front floor with storage and rear HVAC vents (requires custom trim)	A	S
Cruise control	S	S
Deck lid release (with trunk valet feature)	A†	S
Defogger, electric rear window	S	S
Door locks, power, automatic with lockout protection and delayed locking feature	S	S
Illuminated entry system	A†	S
Interior: AS7 45/45 bucket seats (Cartagena cloth, illuminated visor vanity mirrors, console with rear heater/air conditioning vents, overhead console with power outlet† and floor mats). Leather seating areas also available	A	S
Instrumentation: Backlit, analog, speedometer, tachometer, fuel, coolant temperature, battery voltage and oil pressure	S	S
Systems monitor includes coolant temperature, oil pressure indicator, battery voltage and parking brake light	S	-
Electronic compass Driver Information Center includes: Check oil level, washer fluid low, low coolant, check gauges (oil pressure, battery voltage, coolant temperature), hood ajar, trunk ajar and lamp monitor (supercharged models include boost gauge)	-	S
EyeCue Head-Up Display	-	A†
Keyless entry system, remote with panic button, personalization feature	A	S
Lamps: IP, ashtray, glove box, trunk, front overhead console/† reading, headlamp-on warning, rear assist handle, rear rail reading and theater dimming	S	S
Luggage compartment convenience net (requires custom trim)	A	S
Mats: Front and rear floor	S	S
SSE-specific, front and rear floor	-	A
Mirrors: Visor vanity, RH and LH covered	S	-
Illuminated visor vanity, RH and LH covered	A†	S
Electrochromic, inside rearview	-	A†
Power windows with driver's "express-down" feature	S	S
Radios: Delco ETR AM/FM stereo with clock (UM7)	S	-
Delco 2001 Series ETR AM/FM stereo with auto-reverse cassette, clock, seek up/down and Delco TheftLock (UN6)	A	A
Delco 2001 Series ETR AM/FM stereo with compact disc player. Includes clock, seek up/down, search and replay and Delco TheftLock (UIC)	A	A
Delco 2001 Series ETR AM/FM stereo with auto-reverse cassette and 7-band graphic equalizer. Includes clock, touch control, seek up/down, search and replay, leather-wrapped steering wheel with radio controls, power antenna, Delco TheftLock and 6-speaker system on SE and SSE with ISA (UT6)	A	S
Delco 2001 Series ETR AM/FM stereo with compact disc player and 7-band graphic equalizer. Includes clock, touch control, seek up/down, search and replay, leather-wrapped steering wheel with radio controls, power antenna, Delco TheftLock and 6-speaker system on SE and SSE with ISA (UP3)	A	A
4-speaker system (not available with UT6/UP3 radios)	S	-
6-speaker system (not available with UM7 radio)	A	S
Bose 8-speaker system (not available with UN6 or UIC radios)	-	A†
Rear-seat pass-through	S	S
Seats: 45/55 split bench with manual recliners and storage armrest with dual cupholders, Cartagena cloth trim	S	-
45/45 bucket with center console storage, Cartagena cloth trim (requires custom trim)	A	S
45/45 bucket - leather seating areas, non-articulating (requires custom trim and 6-speaker sound system)	A	A
45/45 articulating 12-way power, driver and front passenger - leather seating areas	-	A†
Power driver seat, 6-way (bench)	A	-
Power driver seat, 6-way (bucket)	A	S
Power passenger seat, 6-way (bench) (requires custom trim on SE)	A	-
Power passenger seat, 6-way (bucket) (requires custom trim on SE)	A	A†

Interior Features (continued)	SE	SSE
Steering wheels: 4-spoke, urethane, Dark Pewter color	S	-
4-spoke, leather-wrapped w/radio controls (included with UT6/UP3 radios)	A	S
Tilt-Wheel adjustable steering column, Dark Pewter color	S	S
Storage, rear center armrest with dual cupholder (standard with leather seating areas and requires custom trim)	A	S
Sunroof, power, glass (includes illuminated visor vanity mirrors)	A	A
Theft-deterrent systems: PASS-Key II	S	S
Full-feature theft-deterrent (includes central unlock and fuel-filler door lock)	A	A [†]

*Standard with Y52 CCR/Handling Package. †Available in Option Group only.
 **Always wear safety belts, even in vehicles equipped with air bags. ††Not available with sunroof.

MECHANICAL

Battery, Delco Freedom II with rundown protection feature	S	S
Brakes: Power disc/drum, anti-lock braking system (ABS), 4-wheel	S	S
Brake/transmission shift interlock safety feature	S	S
California/Massachusetts/New York emissions requirements	A	A
Computer Command Ride	-	A
Computer Command Ride (CCR)/Handling Package (Y52) (requires bucket seats)	A	-
Electronic load leveling (included with CCR)	A	S
Engines/Transmissions: 3.8 liter 3800 Series II SFI V6 with electronically controlled 4-speed automatic	S	S
3800 Series II supercharged V6 engine package: Includes P225/60R16 BSW touring tires, 2.93 axle ratio, dual exhaust, Traction Control and driver-select shift controls (requires Sport Luxury Edition on SE)	A	-
SSEi Supercharger Package (WA6): Includes 3800 Series II supercharged V6 with electronically controlled automatic, driver-select shift controls, boost gauge, SSEi floor mats, P225/60HR16 RSA tires, specific cluster, 2.93 axle ratio, Traction Control and SSEi badging	-	A
Exhaust: Stainless steel single	S	-
Stainless steel split dual rectangular (included with supercharged engine)	A	S
Extensive anti-corrosion protection with two-sided galvanized steel doors, quarter panels, hood, deck lid and rockers	S	S
Steering: Power rack-and-pinion	S	S
Magnasteer variable-effort (available in Option Group only)	A*	S
Tethered fuel cap (with 3800 Series II V6 only)	A	A
Traction Control (requires 45/45 bucket seats and 16" wheels and tires) (requires custom trim)	A	A

*Standard with Y52 CCR/Handling Package.
 S = Standard. A = Available. - = Not available.

ENGINES

	3.8 liter 3800 SFI Series II V6	Supercharged 3.8 liter 3800 SFI Series II V6
SE	S	A*
SSE	S	A
SSE**	-	A
Horsepower	205 @ 5,200 rpm	240 @ 5,200 rpm
Torque	230 ft.-lbs @ 4,000 rpm	280 ft.-lbs @ 3,200 rpm
4-speed automatic	S	S

*Requires SLE package and Traction Control. **With SSEi Supercharger Package.

SPECIFICATIONS

Engine/drive	Front engine, front-wheel drive
Curb weight (SE)	3,446 lbs.
Fuel tank capacity	18 gallons

DIMENSIONS

		SE	SSE
Interior	Headroom, Dr	39.2/38.3 [†]	39.2/38.3 [†]
	Legroom, Dr	42.6/38.0 [†]	42.6/38.0 [†]
	Shoulder room, Dr	59.8/59.4 [†]	59.8/59.4 [†]
	Hip room, Dr	57.2/57.1 [†]	57.2/57.1 [†]
	Trunk capacity	18 cu. ft.	18 cu. ft.
Exterior	Wheelbase	110.8 [†]	110.8 [†]
	Overall length	200.5 [†]	202.1 [†]
	Width	74.5 [†]	74.5 [†]
	Overall height	55.7 [†]	55.7 [†]
	Tread, Dr	60.4/60.3 [†]	60.8/60.6 [†]

OPTION GROUPS

Some available options may require additional equipment. See your dealer for details.

RPO	SE	SLE	SSE
1SB Trunk storage net	■	■	S S
C97 Illuminated entry system	■	■	S S
UN6 AM/FM stereo with auto-reverse cassette, with clock and seek/scan	■	■	UT6 UIC
A90 Deck lid release, remote	■	■	S S
DG7 Mirrors, Sport LH power and RH power convex	■	■	DK5 DK5
AG1 Power driver seat, 6-way	■	■	S S
NV8 Variable-effort power steering (Magnasteer)	■	■	S S
DH6 Mirror, illuminated visor vanity, LH and RH	■	■	S S
NP5 Steering wheel, leather-wrapped (includes leather shifter with AS7 seats on SE)	■	■	S S
AU0 Remote keyless entry (includes panic mode, activation verification, retained accessory power and personalization)	■	■	S S
C68 Automatic air conditioning system	■	■	S S
H4U Sport Luxury Edition: Includes leather 45/45 seating areas and steering wheel, P225/60R16 BSW touring tires, rear deck lid spoiler, 3.06 axle ratio, 6-speaker sound system, 5-spoke cast aluminum wheels (PF5) and power antenna	■	■	N/A N/A
UV6 EyeCue Head-Up Display	■	■	■
DD8 Electrochromic inside rearview mirror	■	■	■
UZ8 Bose 8-speaker sound system	■	■	■
AG2 Power seat, passenger, 6-way	■	■	■
UA6 Theft-deterrent/alarm system (full feature, lights/horn, includes fuel door lock)	■	■	■
NW9 Traction Control	■	■	■

■ = Included in Option Group. S = Standard.

EXTERIOR COLORS

16 Bright White	47 Gray-Green Metallic, SE only
34 Silver-Teal Metallic, SE only	48 Dark Green Metallic
41 Black	50 Silver-Taupe Metallic
42 Medium Jade-Gray Metallic, SE only	53 Medium Red Metallic, SE only
45 Medium Dark Teal Metallic	77 Dark Cherry Metallic

These simulated body panels represent the range of exterior colors available on new Bonnevilles for 1997.

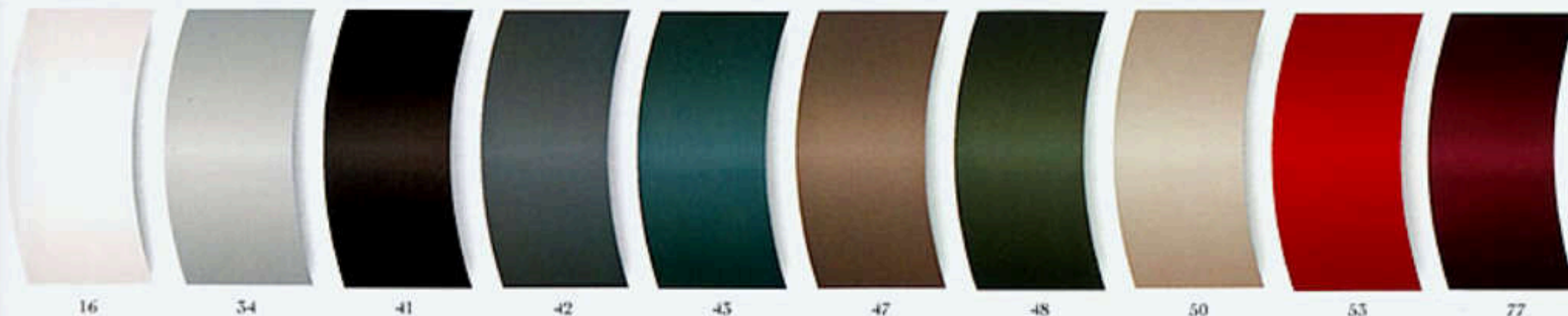

16

34

41

42

45

47

48

50

53

77

Bonneville Occupant Protection and Crash Avoidance Features

To help contribute to driving safety, each of the following features is included in the Bonneville line:

Occupant Protection

- ▶ Manual lap/shoulder safety belts for all outboard positions.
- ▶ Driver and front passenger air bags.
- ▶ Manual lap safety belts, center seating positions.
- ▶ Available illuminated entry.
- ▶ Energy-absorbing steering column.
- ▶ Energy-absorbing instrument panel.
- ▶ Folding front seatback locks, inertia type.
- ▶ Safety armrests.
- ▶ Breakaway inside rearview mirror.
- ▶ Security door locks and door retention components.
- ▶ Laminated windshield glass, urethane bonded.
- ▶ Head restraints, adjustable, front.
- ▶ Side door beams.
- ▶ Passenger-guard inside door lock handles.

Crash Avoidance

- ▶ Anti-lock braking system, four-wheel.
- ▶ Brake/transmission shift interlock.
- ▶ Automatic daytime running lamps.
- ▶ Side marker lamps.
- ▶ Parking lamps.
- ▶ Four-way hazard warning flashers.
- ▶ Backup lamps.
- ▶ Directional signal control.
- ▶ Windshield defroster, washer and multi-speed wipers.
- ▶ Inside day/night rearview mirror.
- ▶ Outside rearview mirrors.
- ▶ Center high-mounted stop lamp.
- ▶ Brake system with dual master cylinder plus warning light.
- ▶ Starter safety switch.
- ▶ Low-glare finish – inside windshield moldings, wiper arms and blades, metallic steering wheel surfaces, inside rearview mirror frame and bracket.

- ▶ Dual-action hood latch (front opening).
- ▶ Illuminated heater and defroster controls.
- ▶ Tires with built-in tread wear indicators.

Theft Deterrence

- ▶ Visible vehicle identification number.
- ▶ Laser-etched VIN plate.
- ▶ Marked body parts.
- ▶ Theft-deterrent steering column lock.
- ▶ Theft-deterrent key locking system.
- ▶ PASS-Key II theft-deterrent system.
- ▶ Remote inside hood release.

And now, a word about...

This Catalog:

We've tried to make this catalog as comprehensive and factual as possible. We reserve the right, however, to make changes at any time, without notice, in prices, colors, materials, equipment, specifications, models and availability. Since some information may have been updated since the time of printing, please check with your Pontiac dealer for complete details.

Engines:

Pontiac models are equipped with engines produced by different operating units of GM, its subsidiaries or suppliers to GM worldwide.

Updated Service Information:

Pontiac regularly sends its dealers useful service bulletins about Pontiac products. Pontiac monitors product performance in this field. We then prepare bulletins for servicing our products better. Now you can get these bulletins too. Ask your dealer. To get ordering information, call toll-free 1-800-551-4125.

The Assembly of Bonneville:

Bonneville is assembled by different operating units of General Motors, its subsidiaries or suppliers to GM worldwide. Bonneville incorporates thousands of components produced by different operating units of GM, its subsidiaries or suppliers to GM world-

wide. We sometimes find it necessary to produce Bonneville's with different or differently sourced components than originally scheduled. All such components have been approved for use in Bonneville's and will provide the quality of performance associated with the Pontiac name. Since some options may be unavailable when your vehicle is assembled, we suggest you verify that your vehicle includes the equipment you ordered, or if there are changes, that they are acceptable to you.

Warranty Protection:

Bonneville's 3-year/36,000-mile (whichever comes first) no-deductible bumper-to-bumper limited warranty covers repairs, including labor and parts, to correct any defects in material or workmanship occurring during the warranty period. The complete vehicle is covered, except for adjustments and normal maintenance.

Corrosion Protection:

Bonneville is designed and built to resist corrosion. All body and sheet metal components are warranted against rust-through corrosion for 6 years or 100,000 miles, whichever comes first. Application of additional rust-inhibiting materials is not required under the corrosion coverage and none is recommended. See your Pontiac dealer for terms of these limited warranties.

PONTIAC, THE PONTIAC EMBLEM, GENERAL MOTORS, THE GM EMBLEM, SOFT-RAY, TWILIGHT SENTINEL, WE ARE DRIVING EXCITEMENT, ETR, FREEDOM, PONTIAC CARES, SSE and BONNEVILLE are registered trademarks of the General Motors Corporation. MAGNASTEER and SSEi are trademarks of the General Motors Corporation. PASS-KEY and THEFTLOCK are registered trademarks and EYEUCUE is a trademark of the Delco Electronics Corporation.



ALWAYS WEAR SAFETY BELTS, EVEN IN VEHICLES EQUIPPED WITH AIR BAGS. © 1996 GENERAL MOTORS CORPORATION. ALL RIGHTS RESERVED. LITHO IN U.S.A.



PONTIAC
WE ARE DRIVING EXCITEMENT