



2021 RAM PROMASTER CITY

THE BUSINESS OF MOVING CARGO AND PEOPLE



CARGO VAN



WAGON



CARGO HAULER MEETS PEOPLE CARRIER. Every day, business owners strive to lower costs, increase efficiencies and make sure they're using the best tools for the job. With commercial-grade capabilities, a robust powertrain, must-have technology and multiple best-in-class features, Ram ProMaster City® hits every target. Available in two models, each one offers customizable interiors perfectly suited for businesses, organizations, shuttles, families and weekend warriors. Spec out your own ProMaster City at ram.com/promastercity

GENERATES THE RIGHT NUMBERS



AMERICA'S MOST EFFICIENT WORK VAN^{1*}

Shown with aftermarket upfit.

CARGO VAN BEST-IN-CLASS
28 MPG HWY
FUEL ECONOMY²
2.4L TIGERSHARK[®] MULTI-AIR[®]2 I-4

BEST-IN-CLASS
178 HP 174 LB-FT OF TORQUE⁴
2.4L TIGERSHARK MULTI-AIR[®]2 I-4

CLASS-EXCLUSIVE
9-SPEED
AUTOMATIC TRANSMISSION⁴

CLASS-EXCLUSIVE
BI-LINK REAR
SUSPENSION⁴
OUTSTANDING
COMFORT & STABILITY



0 - 30 MPH IN 3.7 SEC³

CARGO VAN UNSURPASSED
2,000-LB
MAXIMUM TOWING⁴

ENGINE OIL CHANGE INTERVALS
UP TO 10,000 MILES

5 YEAR/60,000 MILE
POWERTRAIN LIMITED WARRANTY⁵

*All disclosures can be found on the last page.

CARGO VAN BEST-IN-CLASS

131.7-CU FT

CARGO CAPACITY (BEHIND FIRST ROW)⁴

CARGO VAN BEST-IN-CLASS

1,890-LB

MAXIMUM PAYLOAD⁴

ACCOMMODATING

OVER 4 FT

BETWEEN WHEEL WELLS

AVAILABLE

RAM TELEMATICS™

WITH TOUCHSCREEN DISPLAY

STANDARD

UCONNECT® 3 WITH

**5-INCH TOUCHSCREEN
DISPLAY**

CONVENIENT

60/40 SPLIT REAR DOORS

DOORS OPEN 180 DEGREES

Designed to accept a standard pallet



OUR NUMBERS SPEAK VOLUMES



WORKHORSE PERFORMANCE



CARGO VAN
BEST-IN-CLASS
28 MPG HWY FUEL ECONOMY²

LEAN PERFORMANCE BOOSTS THE BOTTOM LINE. Miles count. Efficiency matters. When you pilot a Ram ProMaster City[®], **America's Most Efficient Work Van¹**, you can count on **best-in-class highway fuel economy²**. But make no mistake, the robust performance the Ram Brand is known for hasn't been sacrificed. You still get **best-in-class horsepower and torque⁴**, as well as **best-in-class payload⁴**. That's what's known as Ram tough.

ONE-TWO POWER PUNCH



CLASS-EXCLUSIVE 9-SPEED AUTOMATIC TRANSMISSION⁴

- ▶ Equipped with Electronic Range Select (ERS), an electromechanical gear selection system that provides you with manual shift control of the transmission
- ▶ A wide 9.79 ratio spread brings outstanding launch characteristics and smooth, nearly indecipherable transfer between gears
- ▶ Shorter mid-range gears ensure quick transitions, and higher gears—7th, 8th and 9th transitions—relate to lower engine speeds
- ▶ High efficiency in all gears and speeds thanks to nested carriers, dog clutches and advanced hydraulic control unit architecture

2.4L TIGERSHARK[®] MULTIAIR[®] 2 I-4.

- ▶ **BEST-IN-CLASS** HORSEPOWER **178 HP⁴** @ 6,400 rpm
- ▶ **BEST-IN-CLASS** TORQUE **174 LB-FT⁴** @ 3,800 rpm
- ▶ 3.7 seconds from a full stop to 30 mph³
- ▶ Smart pulse-width modulation technology on the alternator and fuel pump helps contribute to operating efficiency
- ▶ Individual-piston oil squirters help keep internal temperatures in the ideal range
- ▶ Position of the exhaust manifold helps minimize noise in the engine compartment
- ▶ Runs on 87-octane gasoline
- ▶ 5-Year/60,000-Mile Powertrain Limited Warranty⁵





STRONG & CAPABLE



BEST-IN-CLASS: CARGO CAPACITY **131.7 CU FT** (BEHIND FIRST ROW)⁴

DIMENSIONS OF CONVENIENCE

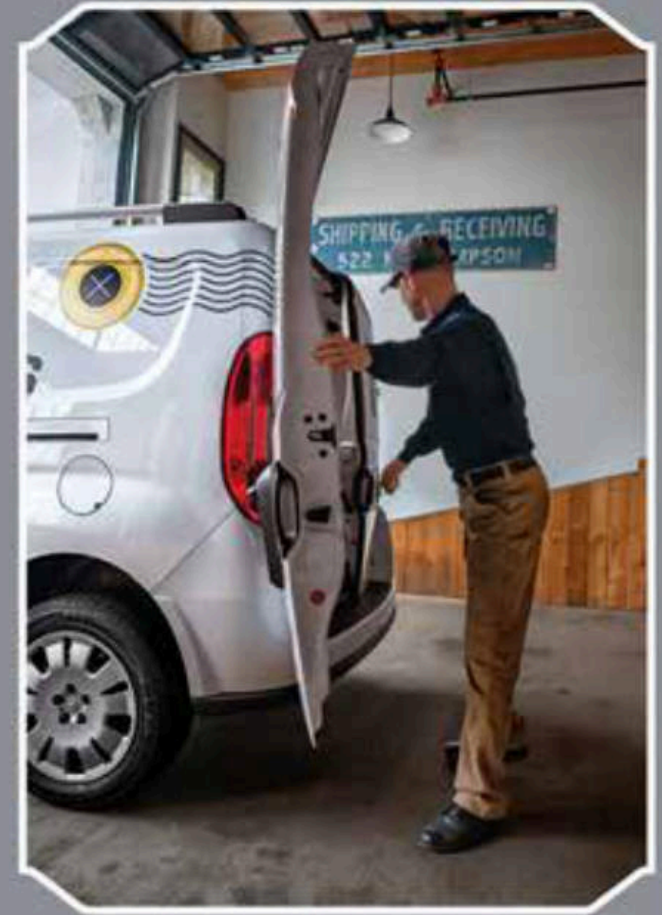
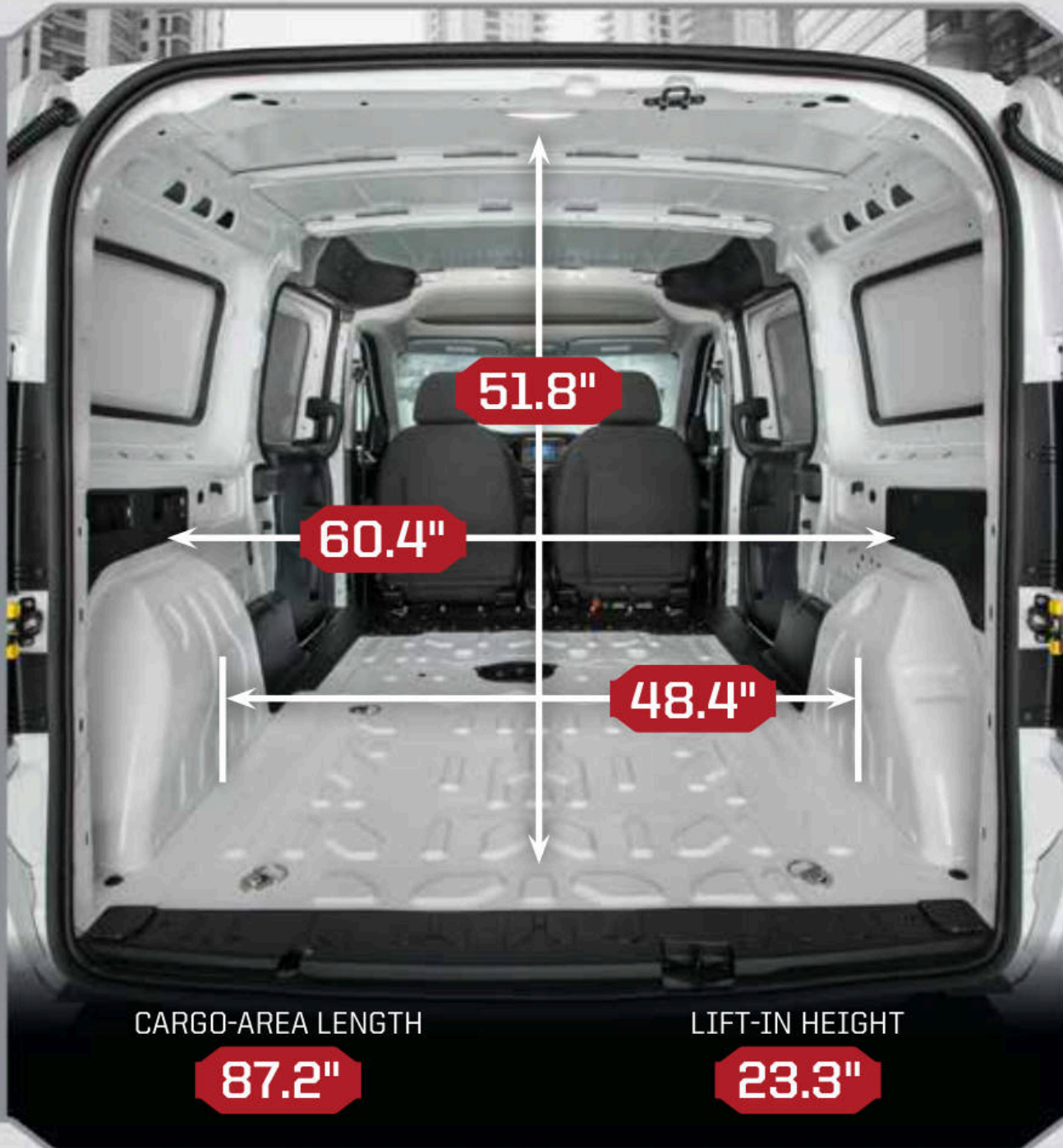

WORK WITH THE RIGHT EQUATIONS. Ram ProMaster City® Cargo Van boasts serious credentials. More than 4 feet between the rear wheel wells allows building materials, pallets and bulky supplies to be loaded easily. The nearly vertical side-panel construction offers a width of more than 5 feet. Combine that with an interior roof height greater than 4 feet and the result is best-in-class cargo capacity of 131.7 cu ft (behind first row)!¹



BEST-IN-CLASS: MAXIMUM PAYLOAD 1,890 LB⁴



6 IN-FLOOR TIE-DOWN RINGS
(STANDARD ON CARGO VAN)

4 IN-FLOOR TIE-DOWN RINGS (STANDARD ON WAGON)



HIGHLY FUNCTIONAL WORKSPACES

INTERIORS THAT WORK FOR YOU



Shown with aftermarket upfit.

MAKE IT PERSONAL. From the first sketch on the design board, the focus was threefold: make it big, make it user-friendly, make it versatile. This is why you'll find a huge interior made for customized upfits, an easy-to-load floor height, and near-vertical side walls that are upfitter-friendly and make installing specialized commercial shelves or storage

racks a breeze. When you're in and out of your van all day long, you'll appreciate low lift-in height of 23.3 inches at the rear and step-in height of 21.5 inches at the side. Enjoy easy loading and unloading at the sides with dual sliding doors that open up to an ample 25.8 inches wide and a flat load floor.



Shown with aftermarket upfit.

CONFIGURE FOR THE TASK AT HAND



OPEN TO CABIN Standard on Tradesman® Cargo Van and SLT Cargo Van



PARTITION Available for Tradesman Cargo Van and SLT Cargo Van



PARTITION WITH WINDOW Available for Tradesman Cargo Van and SLT Cargo Van

RAM PROMASTER CITY®
HAS THE DOOR & WINDOW
COMBINATION YOU NEED.



Go to **PAGES 42 & 43** for complete door/window combination information.

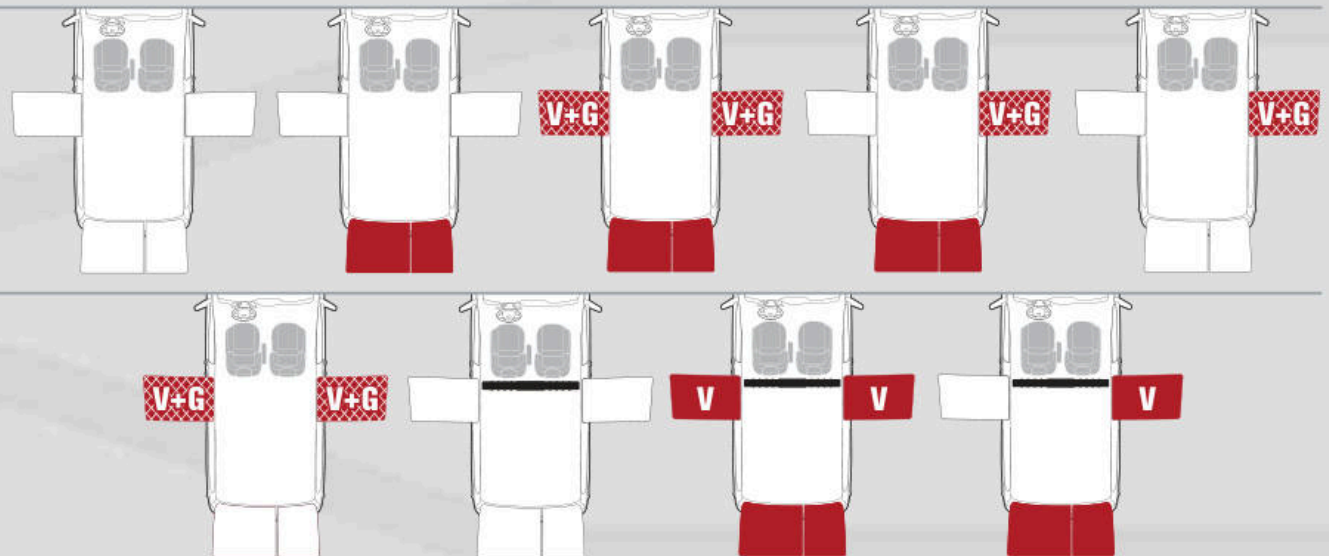

ROOF CAPACITY THAT INCREASES YOUR CAPABILITIES

150-LB⁶

ROOF WEIGHT CAPACITY

TOP-LEVEL CARGO MANAGEMENT.

Every Ram ProMaster City[®] has a max roof weight rating of 150 lb⁶ that accommodates a variety of optional equipment to help make sure you can get where you're going with everything you need loaded. The six ready-to-use anchor points make it easy, especially for Side Rails with Adjustable Crossbars, available through Mopar[®]. For a complete inventory, search mopar.com

Shown with aftermarket upfit.



A top-down view of a white cargo van roof. Six red arrows point to specific anchor points on the roof: three on the front edge and three on the rear edge. The arrows are arranged in two columns of three. The text is centered on the roof.

6 READY-TO-USE ROOF ANCHOR POINTS

(STANDARD ON CARGO VAN AND WAGON. MAX 150-LB⁶ ROOF WEIGHT CAPACITY)



PROVEN METTLE

THE MECHANICS OF STRENGTH AND CAPABILITY

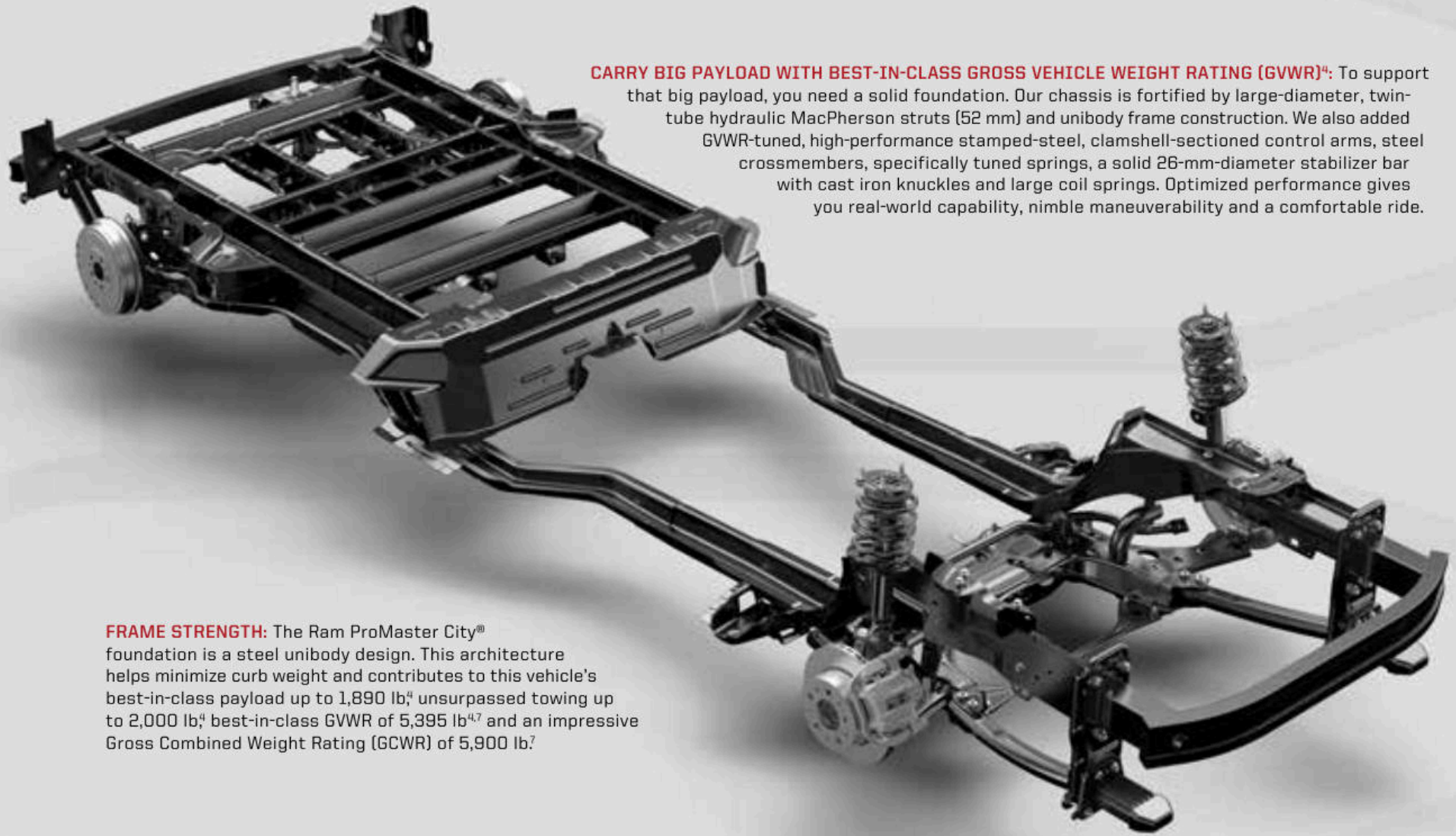

CARRY BIG PAYLOAD WITH BEST-IN-CLASS GROSS VEHICLE WEIGHT RATING (GVWR)⁴: To support that big payload, you need a solid foundation. Our chassis is fortified by large-diameter, twin-tube hydraulic MacPherson struts (52 mm) and unibody frame construction. We also added GVWR-tuned, high-performance stamped-steel, clamshell-sectioned control arms, steel crossmembers, specifically tuned springs, a solid 26-mm-diameter stabilizer bar with cast iron knuckles and large coil springs. Optimized performance gives you real-world capability, nimble maneuverability and a comfortable ride.

FRAME STRENGTH: The Ram ProMaster City[®] foundation is a steel unibody design. This architecture helps minimize curb weight and contributes to this vehicle's best-in-class payload up to 1,890 lb,⁴ unsurpassed towing up to 2,000 lb,⁴ best-in-class GVWR of 5,395 lb^{4,7} and an impressive Gross Combined Weight Rating (GCWR) of 5,900 lb.⁷

THE MECHANICS OF AGILITY AND CONTROL



CLASS-EXCLUSIVE: THE BI-LINK REAR SUSPENSION⁴

Unique to the segment, the Ram ProMaster City[®] rear suspension employs a steel crossmember with an optimum weight/stiffness ratio to help improve reaction to lateral loads. The results are confident hauling with enhanced stability and handling. Cargo-rated steel coil springs supply high-fatigue endurance, while a 16-mm solid stabilizer bar with optimized torsional stiffness helps ensure long-lasting durability.

RACK AND PINION STEERING & FRONT-WHEEL DRIVE (FWD).

We teamed rack and pinion steering with FWD to give you multiple advantages: a low flat-floor cargo area, low step-in height and a turning diameter of only 42 feet. Our hydraulic-assist system features a premium steering gear tuned for commercial-level demands. The standard adjustable tilt/telescoping steering column is a welcome convenience in the commercial class.

READY IF CALLED UPON

**SEVEN STANDARD AIR BAGS[®]
INCLUDING CLASS-EXCLUSIVE
DRIVER-SIDE KNEE AIR BAG^{4,8}**

Our system includes dual-stage driver and front-passenger air bags[®]; supplemental side air bag[®] inflatable curtains, supplemental front-seat-mounted thorax air bags[®], the class-exclusive driver-side knee air bag^{4,8}, dual front seat belt pretensioners and seat belt load limiters.

**7 STANDARD
AIR BAGS[®]**

CLASS-EXCLUSIVE^{4,8}

Wagon shown. Second-row seating not available in Cargo Van and supplemental driver- and front-passenger side-curtain air bags[®] only cover first row.

A PICTURE MAKES ALL THE DIFFERENCE



PARKVIEW® REAR BACK-UP CAMERA⁹

The standard ParkView Rear Back-Up Camera⁹ automatically shows the rear scene in the Uconnect[®] 3 with 5-inch touchscreen display when in Reverse. The on-screen grid lines help when backing up to docks and trailers or into parking spaces.

PARKSENSE® REAR PARK ASSIST SYSTEM¹⁰

The available ParkSense Rear Park Assist System¹⁰ is an invaluable asset to help keep the driver alert to his or her surroundings. Activated under 8 mph when in Reverse, it detects objects up to 55 inches away (from the center of the rear fascia) and projects audible warnings that increase in intensity as the vehicle nears obstructions to the rear.



INTELLIGENT SECURITY DETAIL



ELECTRONIC STABILITY CONTROL (ESC)¹¹

Every Ram ProMaster City[®] boasts standard Electronic Stability Control (ESC).¹¹ This system integrates the Antilock Braking System (ABS) with a variety of All-Speed Traction Control technologies that enable all four corners of the vehicle to respond to lateral movement and the steering input from the driver. ESC¹¹ helps maintain control under

conditions such as wet or snow-covered roads, during tight turns and when the driver must utilize evasive maneuvers to help counter the unexpected. Calibrated to engine output, ESC¹¹ includes four-channel ABS, Brake/Lock Differential, a full-function All-Speed Traction Control system, Brake Assist, Trailer Sway Damping,¹² Hill Start Assist and Electronic Roll Mitigation.

START WITH A SLEEK CANVAS

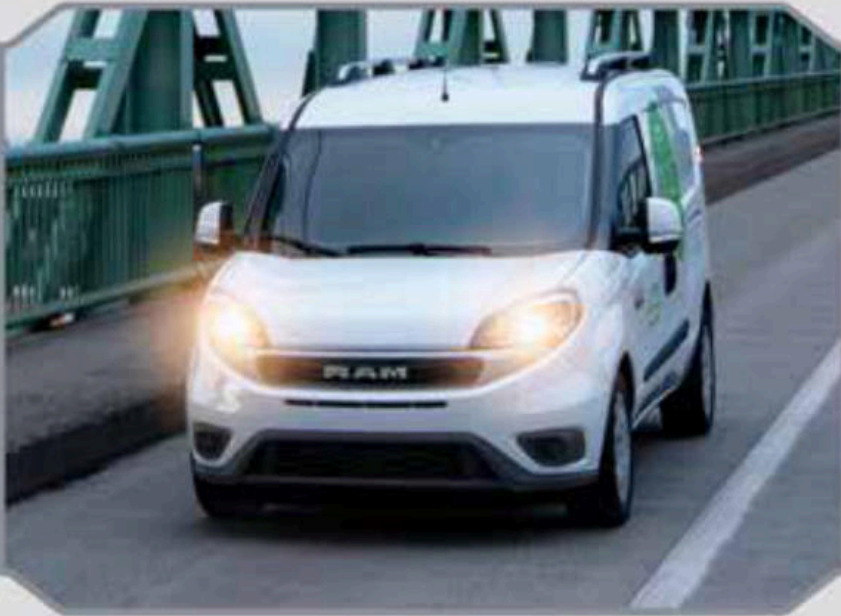

FORWARD LIGHTING.

Headlamps are mounted high above common damage areas to help reduce damage (and costs) in the event of a collision. The system includes the Follow Me Home function, keeping the headlamps lit for a preset time after the engine is shut down to help illuminate your path in the dark.

AERODYNAMIC EXTERIOR.

Thoroughly wind tunnel-tested, Ram ProMaster City® delivers a super-low drag coefficient (CD)—it's a mere 0.30. While this helps enable a remarkably quiet interior, reducing wind resistance also acts as a major contributor to impressive efficiency.





60/40 REAR DOORS



OFFSET DOORS ARE DESIGNED TO BE SIMPLE AND CONVENIENT.

The 60/40 split rear doors were crafted so the larger door swings open toward the road. Not only does this design help shield workers from passing vehicles, it also prevents blocking the path to the curbside of the van. Both doors open 90 degrees initially and can swing out 180 degrees by pressing the release button on the door latch. The latch automatically re-engages when the door is closed.

Shown with aftermarket upfit.

CRAFTED FOR MILES OF COMFORT



STORAGE THAT KEEPS THE CLUTTER AWAY. From the huge in-door pockets (with sculpted bottle holders) to specialized trays to oversized glove compartments, it's all here—even an overhead shelf, two 12-volt auxiliary power outlets, and USB port and connections to charge on-the-go electronics.

TECHNOLOGY THAT CAN GET YOU THERE

UCONNECT® 3.

The standard **Uconnect 3 with 5-inch color display radio system** delivers true fidelity with easy-to-access info through Bluetooth® technology and the color touchscreen.



UCONNECT 3 WITH 5-INCH DISPLAY.

- ▶ AM/FM Stereo
- ▶ MP3 Capability with USB Input
- ▶ Integrated Voice Command
- ▶ Five-inch Color Touchscreen
- ▶ Four-speaker Sound System
- ▶ ParkView® Rear Back-Up Camera⁹



UCONNECT 3 NAV.

The available **Uconnect 3 NAV with 5-inch color display** delivers precise, Web-based GPS Navigation; the available SiriusXM® Radio¹³ includes a six-month trial subscription. Uconnect at your service is made even better by the comprehensive available Ram Telematics.TM



UCONNECT 3 NAV WITH 5-INCH DISPLAY.

All features of the Uconnect 3 with 5-inch display, plus:

- ▶ GPS Navigation
- ▶ Points-of-interest Accessibility
- ▶ Turn-by-turn Navigation

A grayscale photograph of a suspension bridge, likely the Golden Gate Bridge, with a thick rope in the foreground. The bridge's towers and cables are visible in the background, and the water is in the distance. The image has a dark, semi-transparent overlay.

SUPPORT THAT MAKES A DIFFERENCE

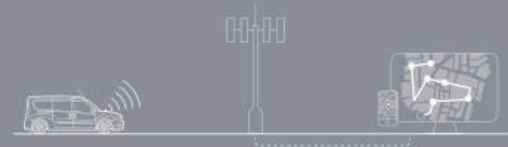

RAM | **RAM TELEMATICS**
— POWERED BY VERIZON CONNECT —

STAY ON TRACK BY KEEPING TRACK.
Simplicity plus complete visibility equals total performance. Vehicle status and history provide insight into vehicle maintenance, workforce management and driver behavior. Just a few of the many advantages:

-  **VEHICLE DIAGNOSTICS**
 - ▶ Oil Life Monitoring
 - ▶ Tire Pressure Monitoring
 - ▶ Diagnostic Trouble Codes

-  **VEHICLE PERFORMANCE**
 - ▶ Fuel Consumption
 - ▶ Idling
 - ▶ Odometer Readings

-  **VEHICLE TRACKING**
 - ▶ GPS Location

-  **DRIVER BEHAVIOR**
 - ▶ Speeding vs. Posted Speed Limit
 - ▶ Hard Braking/Acceleration
 - ▶ ABS/Stability Control Events

-  **DRIVER SAFETY & VEHICLE SECURITY**
 - ▶ Seat Belt Usage
 - ▶ Air Bag[®] Deployment
 - ▶ Unauthorized Vehicle Use

MILES MEASURED IN PRODUCTIVITY

AVAILABLE RAM TELEMATICS,[™] A COMPREHENSIVE SET OF DIAGNOSTICS FOR YOUR RAM PROMASTER CITY.[®] Scalable to fleets of all sizes, factory-installed and backed by a 3-Year/36,000-Mile Basic Limited Warranty,¹⁴ available Ram Telematics monitors key performance metrics in near real time the power you need to transform your business.

Tracking numerous separate mechanical functions—everything from accelerator pedal position to engine info such as coolant level and oil life monitoring—these detailed notifications help keep your Ram vehicle in top-notch condition, let your drivers make informed decisions and help increase uptime.

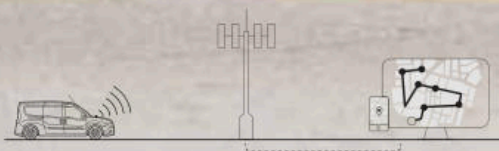

Shown with aftermarket upfit.



ONE PLAN. MULTIPLE DIVIDENDS

AVAILABLE RAM TELEMATICS,™ AN ON-THE-GO OPERATING SYSTEM THAT HELPS DRIVE YOUR BUSINESS. The successful business is efficient, effective and up-to-date, and stays on top of any and all technologies that will help it run better. For fleets both large and small, the state-of-the-art available Ram Telematics is the way to get the best from your Ram ProMaster City.®

Powered by Verizon Connect, available Ram Telematics gives you near real-time on-screen monitoring, provides complete visibility of fleet operations and helps reduce the total cost of ownership.

Activation is easy, with online registration and your choice from one-, three- and five-year plans available.

Get more at ram.com/telematics

Users reporting INCREASES:

-  **53%** PRODUCTIVITY
-  **50%** CUSTOMER SERVICE
-  **45%** ROUTING

YOUR BUSINESS ROLLS WITH BOTTOM-LINE FIGURES. So do we. Here are areas in which fleet tracking users report improvements.

Users reporting DECREASES:

-  **36%** FUEL CONSUMPTION
-  **22%** ACCIDENTS
-  **13%** LABOR COSTS

Source: *2020 Fleet Tracking Trends Report, Verizon Connect (2020)*



RAM PROMASTER CITY® WAGON

PEOPLE, PLACES AND THINGS



PACK FOR ADVENTURE.

Ram ProMaster City® Wagon is ready for adventure. The spacious interior comfortably seats five passengers. Dual side sliding doors provide easy access to rear seats while the 60/40 rear door design lets you load gear with ease. Whether you're hitting the campsite, the beach or somewhere in between, a 1,870-lb⁶ towing rating lets you bring your toys along.

LEAVE NO ONE BEHIND. The confined spaces of the traditional family vehicle are long gone. The area behind Passenger Wagon's upright second-row seats is 74.1 cu ft⁶; fold them down, and the space opens up to 101.7 cu ft⁶

Properly secure all cargo. Animals should always be safely and properly secured while vehicle is in motion.



UNCOMPROMISING FLEXIBILITY



CONFIGURE THE RIGHT MIX. With an interior this flexible, the only thing you're locked into is an interior that adapts to your needs. When rear seats are folded, you've got a cavernous 101.7 cu ft⁶ of max cargo room. At full five-person occupancy, you still have a generous 74.1 cu ft⁶ of cargo room behind the second-row seats.

WINDOW CONFIGURATIONS. We've made virtually every part of this wagon customizable because your transportation needs are unique. The windows are no exception. Choose between vented side windows or power side windows.

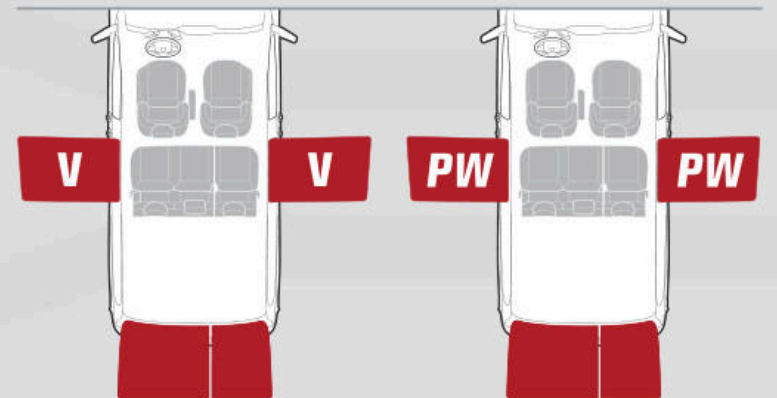

Standard Wagon

Available Wagon
(Included with Taxicab Package
and Popular Equipment Group)

Go to **PAGES 42 & 43** for complete door/window combination information.



READY FOR THE LONG HAUL

ROOM TO RELAX



AMPLE ROOM FOR PEOPLE AND CARGO. If you think that just because this is a wagon we didn't put thought into seating, we have some news to share. The tubular seats feature spring suspensions and adjustable headrests with reclining seatbacks and super-durable fabrics.

Manual supports for the driver seat and heated surfaces for both front seats are available. Rear seats feature innovative Fold-and-Tumble operation with up to nine configurations. Impressive storage, huge cargo room and comfort for everyone make this the wagon of choice.



Shown with aftermarket upfits.

ADAPT TO THE POSSIBILITIES



ADAPTIVE EQUIPMENT UPFITS. The true measure of adaptability is to satisfy challenging demands with dignity, grace and style. Count on Ram ProMaster City® and the FCA DriveAbility Program to help you achieve it.

Expansive side door openings provide huge, unimpeded access to the interior. The flat floor and big 60/40 split rear doors make wheelchair access and mounting apparatus simple. Standard in-floor D-rings (four on Wagon, six on Cargo Van) ensure secure anchoring—and incentives offered by the DriveAbility Program are pocketbook-friendly. Think comfort and operational ease—because our starting point was to make a van that's all about you.

AUTHENTIC ACCESSORIES BY MOPAR.



WHEN IT COMES TO RAM PROMASTER CITY,[®] not all parts and accessories are created equal. As the official service, parts and customer care provider for the Ram Brand, only Mopar Parts and Accessories can ensure the proper fit, finish and functionality. That's because they're original equipment, engineered by the same people who designed your vehicle, which means you can personalize your ride with complete confidence.

Mopar is also more than parts and accessories. We're here to help you properly maintain and care for your vehicle. Our certified technicians are trained to know your vehicle best, and our Mopar Express Lane service departments are set up to get you in, out and back on the road. From parts and accessories to expert service and more, always be sure to choose Mopar. Learn more at mopar.com



- A. LED Cargo-Area Lights
- B. Hitch Receiver¹⁵
- C. Molded Splash Guards
- D. All-Weather Floor Mats, First Row
- E. All-Weather Floor Mats, Second Row

NO WASTE OF SPACE

RAM PROMASTER CITY® IS READY-MADE TO GIVE YOU MORE.

The roof on every model features six ready-to-use anchor points designed to perfectly fit the optional factory-installed Mopar® Side Rails with Adjustable Crossbars or the Mopar Three-Bar Utility Roof Rack. Many other accessories are also available from Mopar to fit your needs. Learn more at mopar.com



Three-Bar Utility Roof Rack (shown with PVC Carriers¹⁶)



Side Rails with Adjustable Crossbars and Roof-Mount Ski and Snowboard Carrier¹⁷



Side Rails with Adjustable Crossbars and Roof-Top Cargo Box¹⁷



BUILD YOUR IDEAL WORKHORSE

RAM PROMASTER CITY® BUYER'S GUIDE

ENGINE/TRANSMISSION

	SALES CODE	Wagon	Wagon SLT	Tradesman® Cargo Van	Tradesman SLT Cargo Van
2.4L TIGERSHARK® MULTI-AIR® 2 I-4 ENGINE/9-SPEED AUTOMATIC TRANSMISSION	ED6/DFH	•	•	•	•

MECHANICAL FEATURES

	SALES CODE	Wagon	Wagon SLT	Tradesman® Cargo Van	Tradesman SLT Cargo Van
ALTERNATOR – 160-amp	BAB	•	•	•	•
BATTERY – 700-amp, maintenance-free	BC8	•	•	•	•
BRAKES – Four-wheel antilock	BGK	•	•	•	•
FUEL TANK – 16-gallon	NFZ	•	•	•	•
UPFIT INTERFACE CONNECTOR (included with Taxicab Package)	BC3	0/P	0	0	0

EXTERIOR FEATURES

	SALES CODE	Wagon	Wagon SLT	Tradesman® Cargo Van	Tradesman SLT Cargo Van
R-A-M GRILLE	ME6	•	•	•	•
BODYSIDE MOLDING – Black	MJA	•	•	•	•
BUMPERS – Front and rear, Black	MLM	•	–	•	–
– Front and rear, body-color	MLA	–	•	–	•
DAYTIME RUNNING LAMPS	LMK	0	0	0	0
DOORS/WINDOWS – SEE COMPLETE CHART ON NEXT PAGE					
– Window Group 01 – Includes rear hinged doors with fixed glass and sliding side doors with vented glass (Wagon models only)	GC4	•	•	–	–
– Window Group 02 – Includes power second-row windows and rear doors with fixed windows (included with Taxicab Package and Popular Equipment Group)	GCK	P	P	–	–
– Window Group 03 – Includes side and rear doors with solid panels	GC1	–	–	•	•
– Window Group 04 – Includes left and right sliding door panels/rear doors with fixed windows	GC2	–	–	0	0
– Window Group 05 – Includes left and right sliding cargo doors with grates and vented glass/rear doors with fixed windows	GCY	–	–	0	0
– Window Group 06 – Includes left and right sliding doors with vented side windows/rear doors with fixed windows (requires Cargo Partition Package – Solid or Cargo Partition Package – Window)	GC3	–	–	0	0

EXTERIOR FEATURES (continued)

	SALES CODE	Wagon	Wagon SLT	Tradesman Cargo Van	Tradesman SLT Cargo Van
– Window Group 07 – Includes left sliding cargo door panel/right sliding door with grate and vented window/rear doors with fixed windows	GCP	–	–	0	0
– Window Group 08 – Includes left sliding cargo door panel/right sliding cargo door with vented glass/rear doors with fixed windows (requires Cargo Partition Package – Window or Cargo Partition Package – Solid)	GCT	–	–	0	0
– Window Group 09 – Includes left sliding door panel and right sliding cargo door grates with vented windows/rear door panels	GCM	–	–	0	0
– Window Group 10 – Includes left/right sliding cargo doors with grates and vented glass/rear door panels	GCU	–	–	0	0
– Rear doors with 180-degree opening	GLG	•	•	•	•
FOG LAMPS – Front (packaged with Lights and Wheels Group)	LNJ	0/P	0/P	0/P	0/P
GLASS – Deep-tint	GEG	0	•	0	•
HEADLAMPS – Halogen	LMA	•	•	•	•
MIRRORS – Remote, manual-adjustable	GTZ	•	–	•	–
– Power-adjustable, folding, heated with body-color caps	GTS	–	•	–	•
ROOF RACK – Side Rails with Adjustable Crossbars (by Mopar®)	MWE	0	0	0	0
CROSSBARS – Three-Bar Utility (not available with Side Rails with Adjustable Crossbars; by Mopar)	MWM	0	0	0	0
TIRES – 215/55R16XL BSW All-Season	TMC	•	•	•	•
WHEELS – 16-inch steel painted Silver with center cap	WDL/WME	•	–	•	–
– 16-inch steel painted Black with full-painted Silver wheel covers (included with Taxicab Package)	WCS	0/P	•	0	•
– 16-inch aluminum (packaged with Lights and Wheels Group)	WDN	P	P	P	P
– Full-size spare tire	TBB	0	0	0	0
– Full-size Spare Tire and Inflator Kit	ACF	0	0	0	0
– Tire Service Kit (includes puncture sealant and portable air compressor)	XAH	•	•	•	•

• = Standard 0 = Optional P = Part of Package F = Fleet only – = Not available

For more information, visit ram.com/promastercity

RAM PROMASTER CITY[®] BUYER'S GUIDE

DOOR/WINDOW CONFIGURATIONS

Due to new Federal Safety Regulations (FMVSS), Ram ProMaster City Cargo Vans equipped with side windows without a partition will be required to have window grates. If a customer does not want a window grate, then the van must be equipped with a partition. Below you will find all available window configurations for 2021MY.

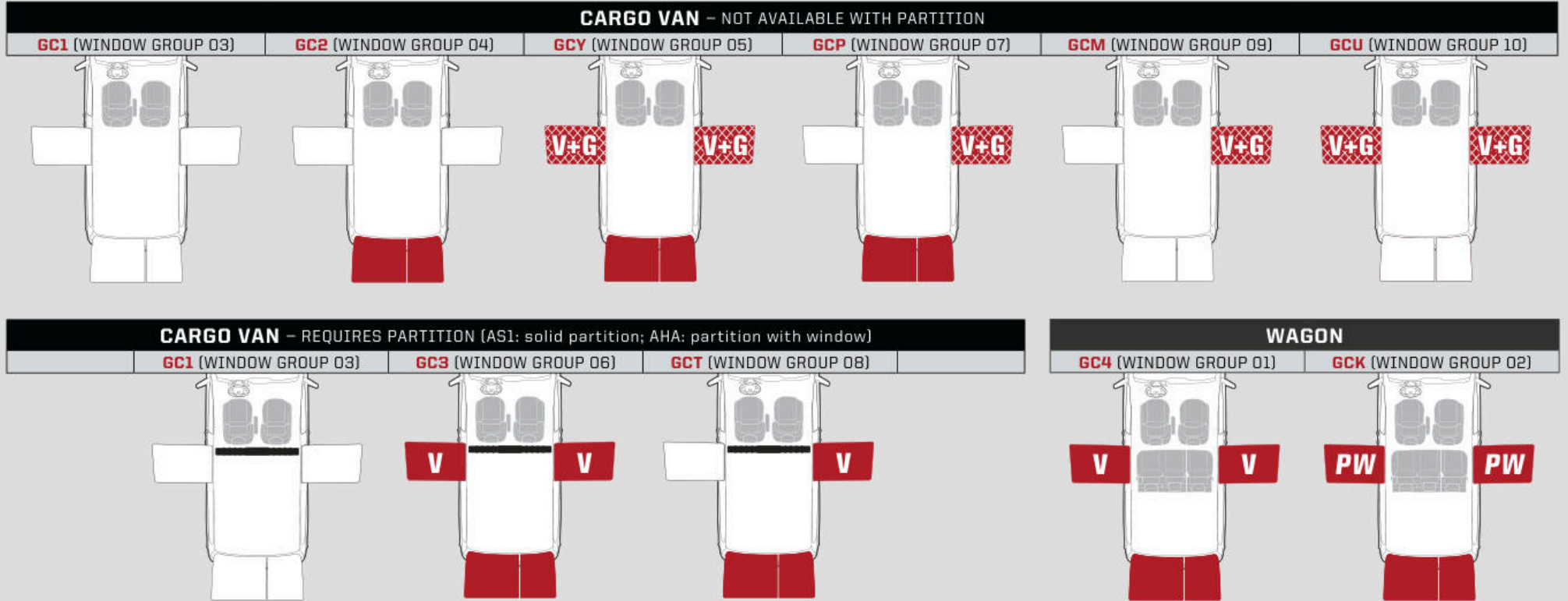

For more information, visit ram.com/promastercity



RAM PROMASTER CITY[®] BUYER'S GUIDE

INTERIOR FEATURES

	SALES CODE	Wagon	Wagon SLT	Tradesman [®] Cargo Van	Tradesman SLT Cargo Van
AIR CONDITIONING	HAA	•	•	•	•
DOOR LOCKS – Power, speed-sensitive	JPH	•	•	•	•
FLOOR MATS – All-Weather Front and Rear (by Mopar [®])	CLF	0	0	–	–
LIGHTING – Map/courtesy/cargo lamps	LBC	•	•	•	•
– LED Cargo Area Lighting (by Mopar)	LCP	–	–	0	0
SEATS – 60/40 Fold-and-Tumble three-person rear bench	CFF	•	•	–	–
– Cloth low-back bucket with manual adjuster	*B7	•	–	•	–
– Heated front (included with Popular Equipment Group)	JPM	–	0/P	–	0/P
– Premium cloth bucket with driver-side manual lumbar and height adjusters	*C7	–	•	–	•
– Premium vinyl bucket with driver-side manual lumbar and height adjusters and passenger-side manual lumbar adjuster (included with Taxicab Package on Wagon; not available with heated front seats)	*N7	0/P	0	0	0
SPEED CONTROL	NHM	0	•	0	•
STEERING COLUMN – Tilt/telescoping	SUD	•	•	•	•
STEERING WHEEL – Base	SCK	•	–	•	–
– Leather-wrapped with audio controls (included with Uconnect [®] 3 NAV with 5-inch display)	SCG	P	•	P	•
WINDOWS – Front, power with one-touch up/down	JP3	•	•	•	•
– Second-row power (included with Window Group 02)	JPG	P	P	–	P
UCONNECT MULTIMEDIA					
UCONNECT 3 WITH 5-INCH DISPLAY – Includes AM/FM and Integrated Voice Command with Bluetooth [®]	UAA	•	•	•	•
UCONNECT 3 NAV WITH 5-INCH DISPLAY AND NAVIGATION – Includes AM/FM/NAV and leather-wrapped steering wheel with audio controls on Tradesman Cargo Van and Wagon models	UAB	0	0	0	0
SIRIUSXM [®] RADIO ¹³ WITH SIX-MONTH TRIAL	RSD	0	0	0	0
SPEAKERS – Four	RCD	•	•	•	•
– Six (packaged with Popular Equipment Group)	RCG	–	P	–	–
RAM TELEMATICS [™] – Includes one-year service	RFQ	0	0	0	0
– Three-year subscription	X9S	0	0	0	0
– Five-year subscription	X9T	0	0	0	0

SAFETY & SECURITY

	SALES CODE	Wagon	Wagon SLT	Tradesman Cargo Van	Tradesman SLT Cargo Van
AIR BAGS ^B – Driver and front-passenger	CGT/CGE	•	•	•	•
– Driver inflatable knee bolster	CGY	•	•	•	•
– Supplemental front-seat side	CJ1	•	•	•	•
– Supplemental side-curtain for 1st and 2nd rows	CJ2	•	•	–	–
– Supplemental side-curtain for 1st row	CJ4	–	–	•	•
DOT-CERTIFIED ROADSIDE SAFETY KIT (by Mopar)	ACL	0	0	0	0
ELECTRONIC STABILITY CONTROL (ESC) ¹¹ – Includes All-Speed Traction Control, Brake Assist, Brake-Lock Differential, Electronic Roll Mitigation, Hill Start Assist and Trailer Sway Damping ¹²	BNB	•	•	•	•
PARKSENSE [®] REAR PARK ASSIST SYSTEM ¹⁰	XAA	0	0	0	0
PARKVIEW [®] REAR BACK-UP CAMERA ⁹	XAC	•	•	•	•
REMOTE KEYLESS ENTRY	GXM	•	•	•	•
TIRE PRESSURE MONITORING (TPM) SYSTEM – Warning lamp	LAB	•	•	•	•
PACKAGES/EQUIPMENT GROUPS					
CARGO PARTITION PACKAGE – Solid - No window - Includes rear-wall trim	AS1	–	–	0	0
– With window - Includes rear-wall trim	AHA	–	–	0	0
LIGHTS AND WHEELS GROUP – Includes front fog lamps and 16-inch aluminum wheels	AZK	0	0	0	0
POPULAR EQUIPMENT GROUP – Includes heated front seats, Window Group 02 and six speakers (Wagon models); heated front seats on Cargo Van	AJY	–	0	–	0
REAR WIPER/WASHER/DEFROSTER GROUP – Includes rear window defroster and rear window wiper/washer (included with Taxicab Package; requires deep-tint sunscreen glass; not available with sliding side and rear doors with solid panels)	AMF	0/P	0	0	0
TAXICAB PACKAGE – Includes Rear Wiper/Washer/Defroster Group; premium vinyl bucket seats; upfit interface connector; two additional key fobs; Black, heated, power-adjustable mirrors; Window Group 02; and 16-inch steel wheels painted Black with full-painted Silver wheel covers	AZ3	F	–	–	–
MOPAR TRAILER TOW GROUP – Includes Class III hitch receiver with four- and seven-pin wiring harness	AHT	0	0	0	0

• = Standard 0 = Optional P = Part of Package F = Fleet only – = Not available

EXTERIOR COLORS



Bright White



Silver Metallic



Black Metallic



Bright Red



Deep Red Metallic



Blue Night Metallic



Quartz Gray Metallic

INTERIOR FABRICS



Black Cloth
Standard on Tradesman® Cargo Van/Wagon



Premium Black Cloth
Standard on SLT Cargo Van/Wagon

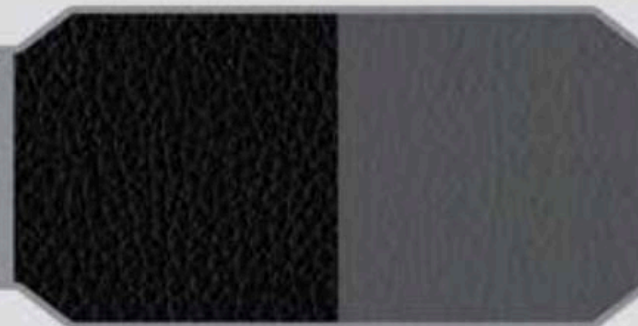

Premium Black Vinyl
(seat surfaces are Diesel Gray Vinyl)
Available on Tradesman and SLT Cargo Van/Wagon
Included with Taxicab Package

WHEELS

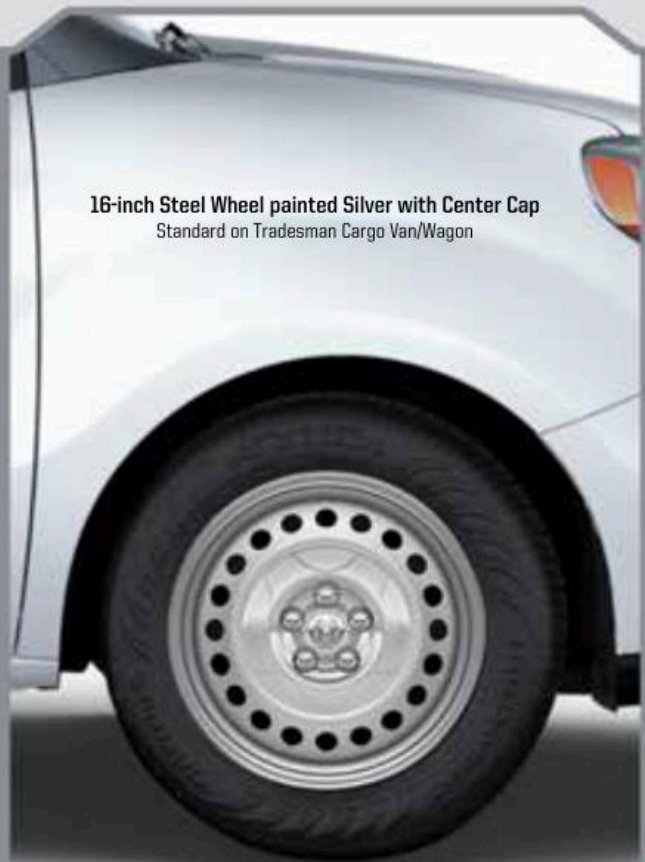

16-inch Steel Wheel painted Silver with Center Cap
Standard on Tradesman Cargo Van/Wagon

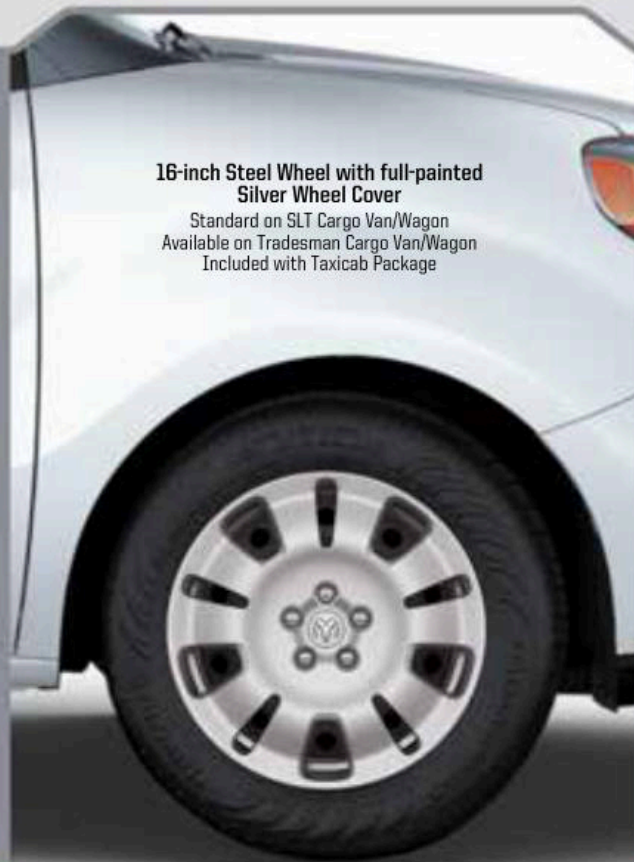

16-inch Steel Wheel with full-painted Silver Wheel Cover
Standard on SLT Cargo Van/Wagon
Available on Tradesman Cargo Van/Wagon
Included with Taxicab Package



16-inch Aluminum Wheel
Available on Tradesman Cargo Van/Wagon
and SLT Cargo Van/Wagon



CHOOSE THE BEST FIT FOR YOU

RAM PROMASTER CITY[®] WAGON & CARGO VAN SPECIFICATIONS

2.4L TIGERSHARK[®] MULTIAIR[®] 2 I-4

HORSEPOWER	BEST-IN-CLASS 178 HP⁴ @ 6,400 rpm
TORQUE	BEST-IN-CLASS 174 LB-FT⁴ @ 3,800 rpm
CONFIGURATION	In-line four-cylinder
DISPLACEMENT	144 cu in (2,360 cc)
BORE x STROKE	3.46 x 3.82 in (88.0 x 97.0 mm)
BLOCK MATERIAL	Aluminum
CYLINDER HEAD MATERIAL	Aluminum
AIR INDUCTION	Naturally aspirated
VALVE TRAIN	Chain-driven DOHC, 16-valve
FUEL DELIVERY	Sequential, multiport injection
RECOMMENDED FUEL	Unleaded regular (87-octane)
COMPRESSION RATIO	10.0:1
ALTERNATOR	160-amp
OIL CAPACITY	5.5 quarts

THE HEART OF THE EFFICIENCY. Mated to the class-exclusive 9-speed automatic transmission,⁴ this proven in-line 4-cylinder powerhouse provides stellar economic figures. Among them: best-in-class horsepower⁴; best-in-class torque⁴; best-in-class highway driving range¹⁸; unsurpassed towing capability—up to 2,000 lb⁴ on Cargo Van models. Finally, it all runs on pocketbook-friendly 87-octane gasoline, with the confidence that comes from a comprehensive 5-Year/60,000-Mile Powertrain Limited Warranty.⁵ In the final analysis, Ram ProMaster City is a rolling example of low costs of ownership and operation.



5 YEAR/60,000 MILE
POWERTRAIN LIMITED WARRANTY

PAYLOAD/TOWING	WAGON	WAGON SLT	TRADESMAN[®] CARGO VAN	TRADESMAN SLT CARGO VAN
GVWR⁷	5,395	5,395	5,395	5,395
GCWR⁷	5,900	5,900	5,900	5,900
CURB WEIGHT	3,683	3,683	3,500	3,500
MAXIMUM PAYLOAD⁸	1,720	1,720	1,890	1,890
MAXIMUM TOWING⁶	1,870	1,870	2,000	2,000

Notes regarding this chart: weights given in lb. Trailer Weight Rating and Tow Vehicle Trailing Weight are calculated as specified in SAE J2807. Driver and passenger weight = 300 lb. Trailer Equipment Weight = 50.7 lb for conventional hitch. Specifications subject to change. See dealer for details.

RAM PROMASTER CITY[®] WAGON & CARGO VAN SPECIFICATIONS

DIMENSIONS (in inches unless otherwise noted)	WAGON	WAGON SLT	TRADESMAN[®] CARGO VAN	TRADESMAN SLT CARGO VAN
CARGO AREA – HEIGHT	48.7	48.7	51.8	51.8
– LOAD FLOOR LENGTH (behind 2nd-row seats on Wagon/second-row seats folded on Wagon)	54.7/69.2	54.7/69.2	87.2	87.2
– VOLUME (cu ft) (behind 2nd-row seats on Wagon/second-row seats folded on Wagon)	74.1/101.7	74.1/101.7	131.7	131.7
DOOR OPENING HEIGHT – REAR CARGO	46.4	46.4	47.4	47.4
– SIDE SLIDING	42.7	42.7	43.6	43.6
DOOR OPENING WIDTH – REAR CARGO	48.6	48.6	48.6	48.6
– SIDE SLIDING	21.2	21.2	25.8	25.8
HEAD ROOM – FIRST-ROW	45.8	45.8	45.8	45.8
– SECOND-ROW	44	44	–	–
HEIGHT – OVERALL	74.2	74.2	74.2	74.2
HIP ROOM – FIRST-ROW	52.8	52.8	52.8	52.8
– SECOND-ROW	59.2	59.2	–	–
LEG ROOM – FIRST-ROW	40.8	40.8	40.8	40.8
– SECOND-ROW	36.8	36.8	–	–
LENGTH – OVERALL BODY	187.1	187.1	187.1	187.1
REAR DOOR LIFT-IN HEIGHT	23.8	23.8	23.3	23.3
SIDE DOOR STEP-IN HEIGHT	19.3	19.3	21.5	21.5
WHEELBASE	122.4	122.4	122.4	122.4
WIDTH – BETWEEN WHEEL WELLS	48.4	48.4	48.4	48.4
– MAXIMUM BETWEEN SIDE PANELS	57.6	57.6	60.4	60.4
– VEHICLE (including mirrors)	84.6	84.6	84.6	84.6

BUSINESS SUPPORT AT THE READY



THE DEALER NETWORK FOR YOUR BUSINESS.

Your **BusinessLink** dealer is committed to providing you, the small business owner, with the vehicle support you need for your business, from servicing all makes and models of your existing lineup to selling you the right vehicles needed to perform the work that you do. Your **BusinessLink** dealer provides priority service because we know downtime is costing you money. **BusinessLink** sales professionals are trained to properly “job-rate” the right vehicle for your work application and provide commercial finance options. New vehicle sales to qualified small business owners also include a free alternate transportation contract, in the event your vehicle is in for service.

Membership is free. Membership helps us to identify you as a small business owner so we can provide you with both the service you deserve and update you with offers that can help reduce the cost of doing business. Ask your **BusinessLink** dealer to register today.

BusinessLink has you covered.

- ▶ Full Range of FCA Commercial Vehicles
- ▶ Free Membership
- ▶ Priority Service
- ▶ Extended Service Hours
- ▶ Dedicated Staff of Commercial Vehicle Experts
- ▶ Free Alternate Transportation
- ▶ Commercial Incentives
- ▶ Expertise in Commercial Financing Options
- ▶ 24/7 Towing Service Available

ON THE JOB

INCENTIVES FOR SMALL BUSINESSES.

Running a business presents plenty of challenges. Like cutting costs, not corners. Like saving time and money while avoiding hassles. The **ON THE JOB**¹⁹ commercial incentive program provides assistance in customizing and servicing your business vehicles.

ON THE JOB¹⁹ allowances make your business more profitable!

- ▶ UP TO \$1,000 Commercial Graphics Program Allowances²⁰
- ▶ UP TO \$1,000 Commercial Equipment/Upfit Allowances²¹

CHRYSLER CAPITAL

A commercial line of credit from Chrysler Capital is ideal for qualified business customers looking for a flexible, easy way to manage growing vehicle needs. Chrysler Capital streamlines the process—and with prequalification, you're ready to buy a vehicle when you need it. Ask your **BusinessLink** dealer for details.

For more information, go to fcausfleet.com/programs/business-link-dealers.html or call us toll-free at **877-2THELINK (877-284-3546)**.

RAM OUTFITTER

BORN UNDER THE RAM LOGO. Ram Outfitter is where you'll find the useful, the cool and the stylish—from clothing and caps to coolers and tools. Make the Ram identity part of your everyday lifestyle. It's all at ram.com/outfitter



RAM

Join fellow Ram enthusiasts and tell your story by posting comments, participating in discussions, and sharing your photos and videos. Join our community on Facebook, Twitter, YouTube and Instagram.

Explore Ram Life at ram.com/ram-life.html



5

1 Based on best-in-class cargo capacity, best-in-class payload and best-in-class hwy mpg. Class is Small Commercial Van segment (Class 1). 2 Class is Small Commercial Van segment. EPA-estimated 28 hwy mpg, 2.4L automatic 9-speed transmission. Actual mileage may vary. 3 Based on manufacturer testing. Always drive carefully, consistent with conditions. Always wear your seat belt and obey posted speed limits. 4 Class is Small Commercial Van segment (Class 1). When properly equipped. See dealer for details. 5 Visit Mopar.com for complete details and a copy of the Powertrain Limited Warranty. 6 When properly equipped. See dealer for details. 7 Assumes properly equipped vehicle and 150-lb allowance for driver. Additional options, equipment, passengers and cargo weight must be subtracted. See dealer for details. 8 Always sit properly in designated seating positions with seat belts securely fastened at all times. 9 Always check entire surroundings visually before proceeding. 10 Always look before proceeding. An electronic drive aid is not a substitute for conscientious driving. Always be aware of your surroundings. 11 Always drive carefully, consistent with conditions. Always wear your seat belt and obey traffic laws. 12 Always drive carefully, consistent with conditions. 13 **DETAILS:** Your service will automatically stop at the end of your trial subscription unless you decide to continue service. If you do not wish to enjoy your trial, you can cancel by calling the number below. **If you decide to continue service after your trial, the subscription plan you choose will automatically renew thereafter and you will be charged according to your chosen payment method at the then-current rates.** Fees and taxes apply. See the SiriusXM Customer Agreement at www.siriusxm.com for complete terms and how to cancel, which includes calling 1-866-635-2349. All fees, content and features are subject to change. 14 Visit Mopar.com for complete details and a copy of the Basic Limited Warranty. 15 Check Owner's Manual for hitch type, load capacity and heavy-duty equipment required. Do not exceed rated tow capacity of the vehicle as equipped. Trailer may require items not supplied by Mopar. 16 Not available from Mopar; sold separately. 17 Carrier mounts to the Mopar Side Rails with Adjustable Crossbars or Mopar Three-Bar Utility Roof Rack; accessories are sold separately. 18 Class is Small Commercial Van segment (Class 1). EPA-estimated 28 hwy and 16-gallon fuel tank, 2.4L automatic 9-speed transmission. Actual mileage may vary. 19 ON THE JOB is a retail incentive program; see your dealer for official rules. Inquire about eligibility by calling 877-ONTHEJOB or by logging on to fcausfleet.com/programs/business-link-dealers.html. The purchaser or lessee must be a qualified commercial customer for more than 30 days prior to the date of the vehicle purchase. An official ON THE JOB Customer Acknowledgment Form must be signed by the customer (provided by the dealer). 20 Allowance varies by graphic program. See dealer for details. Take retail delivery by 01/03/2022. 21 Allowance varies by upfit and model. See dealer for details. Take retail delivery by 01/03/2022.

©2020 FCA US LLC. All Rights Reserved. Ram, Mopar, the BusinessLink design, ParkSense, ParkView, the Ram's Head logo, Ram ProMaster City, Tigershark, Tradesman and Uconnect are registered trademarks, and DriveAbility 8 design, On The Job 8 design and Ram Telematics are trademarks of FCA US LLC. Chrysler Capital is a registered trademark of FCA US LLC and licensed to Santander Consumer USA Inc. MultiAir is a registered trademark of C.R.F. Società Consortile per Azioni, used under license by FCA US LLC.

Bluetooth is a registered trademark of Bluetooth SIG, Inc. Sirius XM Connected Vehicles Services Inc. Sirius, XM and SiriusXM and all related marks and logos are trademarks of Sirius XM Radio Inc. Facebook and logo are registered trademarks of Facebook, Inc. The Twitter logo is a service mark of Twitter, Inc. YouTube and other marks are registered trademarks of Google LLC. Instagram and logo are registered trademarks of Instagram, Inc. Katerack is a registered trademark of Dejana Truck & Utility Equipment Co. All rights reserved.

About this catalog: since the time of publication, some of the information you'll find in this catalog may have been updated. Ask your dealer for details. Some of the equipment shown or described throughout this catalog may be available at extra cost. Specifications, descriptions, illustrative materials and all competitive comparisons contained herein are as accurate as known at the time this publication was approved for printing. FCA US LLC reserves the right to discontinue models at any time or change specifications without notice or without incurring obligation. Options may be required in combination with other options. For the price of the model with the equipment you desire, or verification of specifications contained here, see your Ram dealer.



For more information, visit ram.com/promastercity

Ram is a registered trademark of FCA US LLC.
74-383-2126_12/20