



SAAB 96



Wheel embellishers as illustrated are extra equipment.



### **The Saab 96**

—a handsome, spacious 5-seater, that combines unusual strength and safety, with the get-up-and-go of a sports sedan. Front wheel drive and low center of gravity account for Saab's extreme roadability and instant response. The strong 42 BHP

engine gives fast pickup, and extra passing power on hills and highways. Saab has proved itself in grueling international competition, consistently outpacing and outlasting more expensive cars.

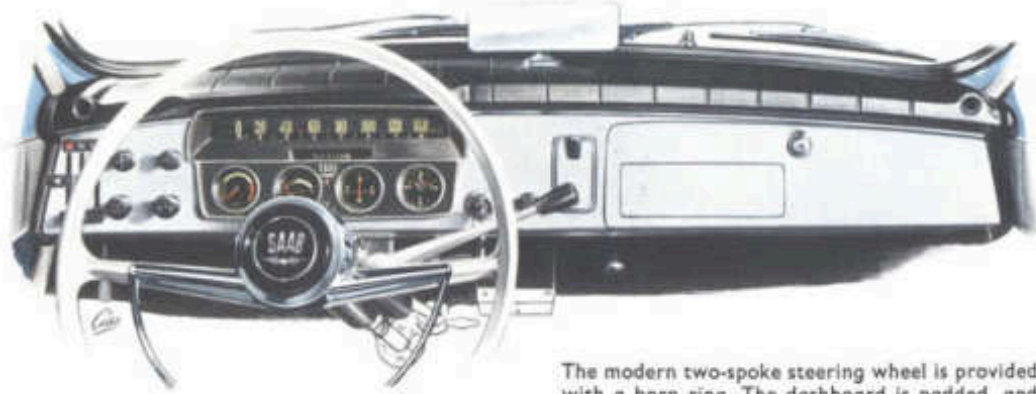

The modern two-spoke steering wheel is provided with a horn ring. The dashboard is padded, and mat finished to cut glare. Instruments, easy to read, include: ribbon type speedometer, temperature gauge, fuel gauge, ammeter and electric clock. The roomy glove compartment includes space for a radio.

A high-efficiency Swedish heater-ventilator system — now thermostatically controlled and having even greater capacity — is standard equipment. Air intake ducts situated high on the hood and discharge ducts by the rear window, provide pleasant airconditioning and prevent window fogging.

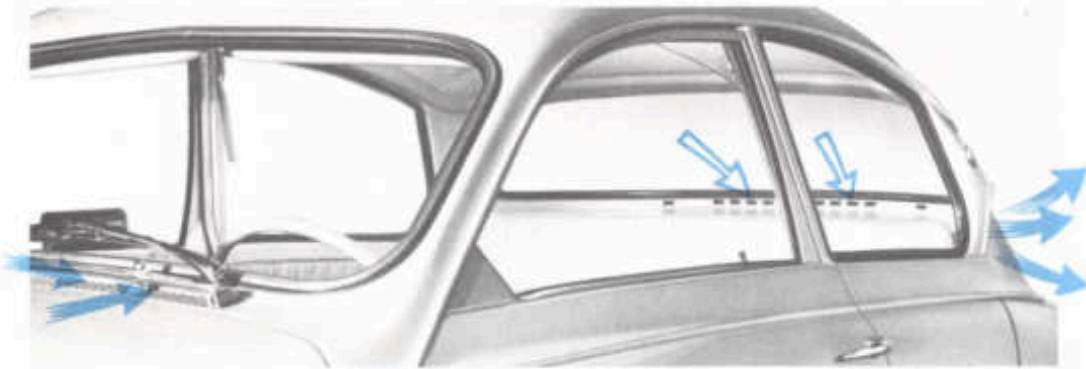

Curved windshield, slender side posts, large side windows, and wrap-around rear window make Saab airy, attractive, and permit 96 percent of full circle visibility from the driver's seat.

*Try the front seat* — note the comfortable driving position, convenient placement of hand brake and gear shift, complete instrumentation, arm rests on the doors and contoured seat backs, adjustable to seven different positions.

*Try the rear seat* — doors are good and wide for safe, comfortable entry. Catches hold doors in open position. The seat can be adjusted to three different heights. The floor is absolutely level, a fringe benefit of Front Wheel Drive.

Special Saab safety features in addition to the padded dash include: safety locks on the doors, padded sun visors, a catch on the right front seat that prevents the back from moving forward if sudden braking is necessary. Exceptionally heavy gauge steel is used in the body which is of unisteel construction. Anchorage points for a combination seat and shoulder harness are built in. The roof is lined with plastic fabric and the whole interior is finished with hardwearing material in well-toned colors. The large choice of harmonious colors available to you are shown below.



# SAAB 96

The famous Saab features—front-wheel drive, perfect weight distribution, solid body construction, low air resistance, and low center of gravity—were part of the very first model. Since then, the characteristic Saab design has been improved continually, but nothing is ever changed just to be different. Today's beautiful Saab 96 is the result of a constant striving to produce a handsome trouble-free family car, with an extra margin of safety built in . . . at the lowest possible price.

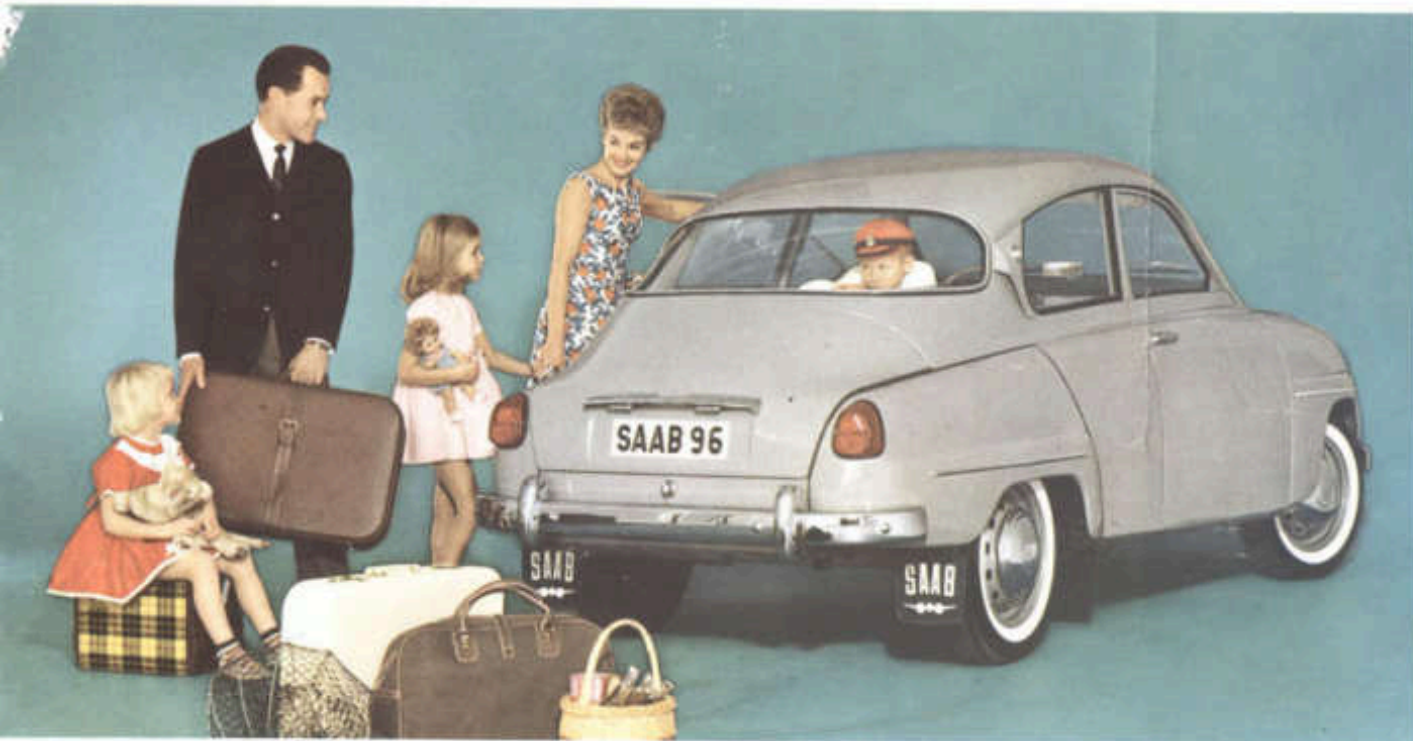

## Look what you get when you choose Saab....

The beautifully engineered Saab motor has only 7 basic moving parts, eliminating 103 chronic trouble spots found in other cars. Front Wheel Drive gives you extra traction to pull, to grip, to go . . . icy or snow-covered roads. Saab is roomy—seats 5 adults in comfort. Saab is economical, with

low fuel consumption . . . requires remarkably little maintenance. Saab with its compact styling is trim and handsome . . . a car with looks as well as character . . . a car for the short hop as well as the long haul . . . most of all, a superbly safe family car.



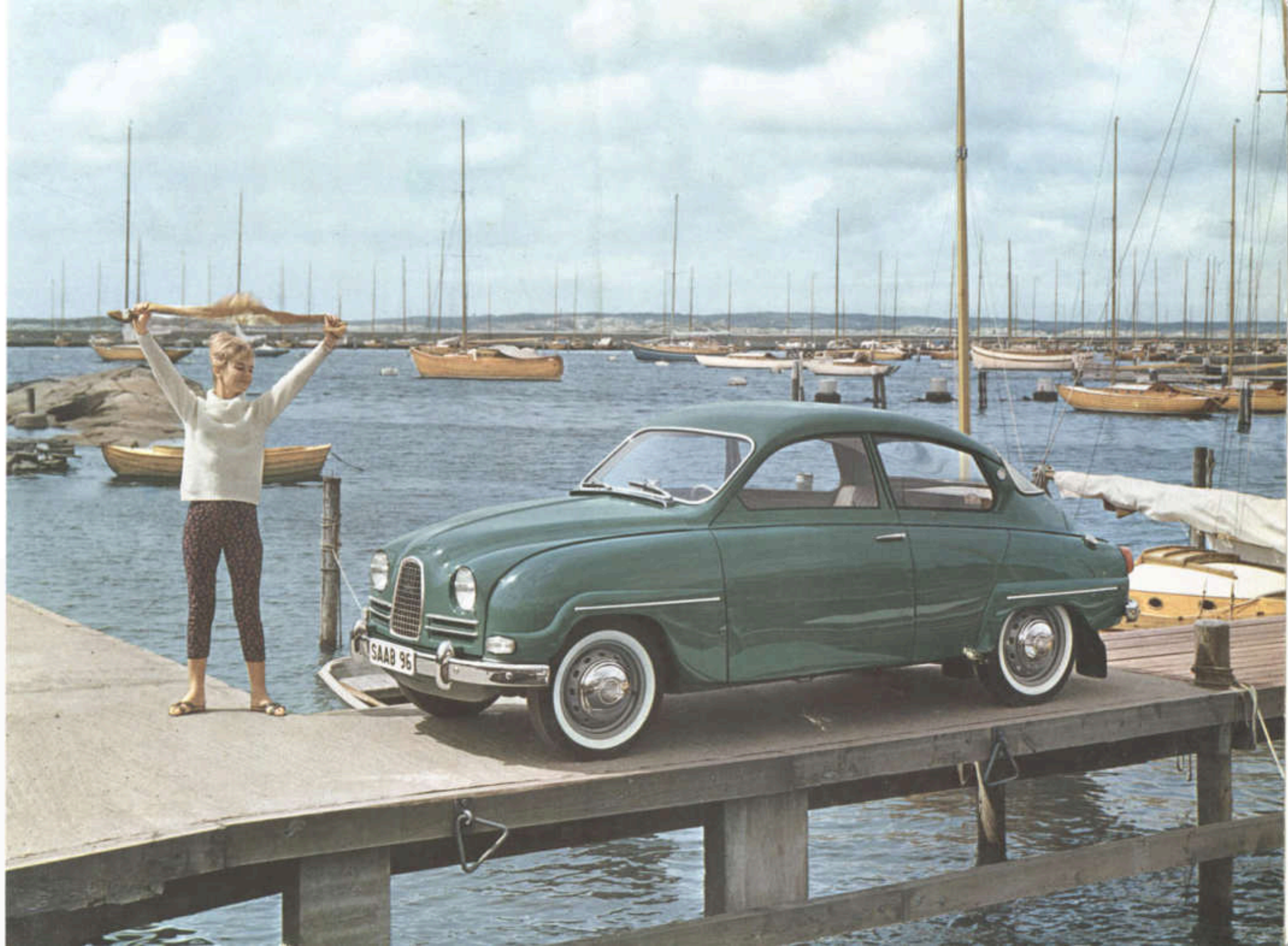

## Long-wearing, dependable engine

The three-cylinder, 42 BHP Saab 96 engine has been exhaustively tested in tough competitive driving over the years. It starts instantly, even at temperatures of 20 below zero.

The two-stroke engine has only 7 basic moving parts: 3 connecting rods, 3 pistons and 1 crankshaft. The crankshaft is supported in the crankcase by four single-row ball bearings, and the big-end bearings of the piston rods are double-row roller bearings.

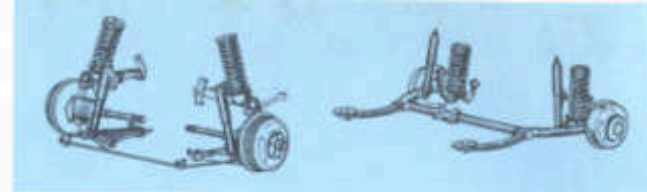
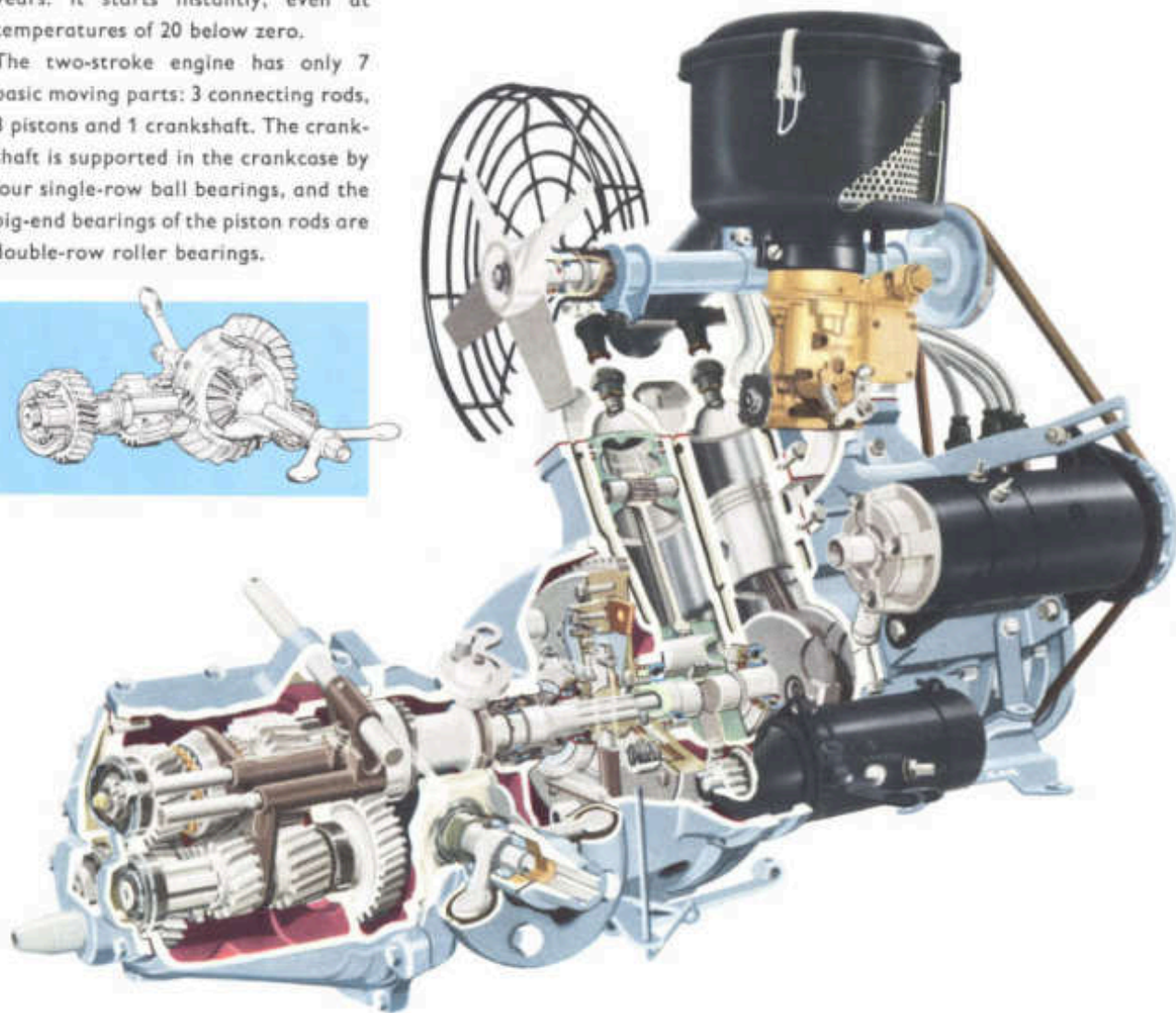
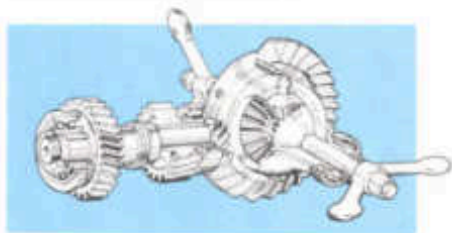

The Saab 96 spring suspension is well-known. All wheels have individual coil springs and direct-acting telescopic shock absorbers... Unsprung weight is low all round. The ingenious rear wheel suspension and balanced weight distribution improve stability on the road. Saab 96 has powerful brakes which take repeated applications and hard use without fading. A pressure-reduction valve prevents the rear wheels from locking prematurely.



One of the many advantages of Saab's front-wheel drive is the way it takes curves. The Saab pulls itself through the sharpest turns. The illustrations below show that most of the car's weight is on the driving wheels, even on fairly steep hills.

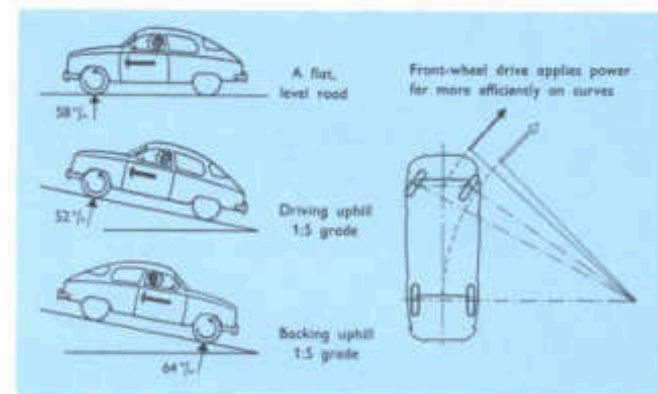



### Sturdily built for trouble-free performance

Saab 96 has a body-frame unit of heavy gauge sheet metal with steel rod reinforcements in the windshield posts. The body is happily free from pockets which collect moisture and dirt. The car is carefully rust-proofed and factory undercoated. The engine, gearbox and differential are located up front, giving traction at the point of action. This, together with 15-inch wheels and unusually high road clearance, gives the Saab exceptional facility

on bumpy, rocky roads. Since all transmission elements are in front, the floor is completely flat.

The trunk is roomy and provided with lighting. The spare tire, tools and jack are stored in a compartment under the trunk. *The gasoline tank is located in the best-protected place — between the rear wheels.* Saab uses standard American SAE sizes.



Instrument panel padded. Two padded safety sun visors.



High-capacity, thermostatically-controlled, adjustable heater-ventilator.



Twin wipers clear windshield all the way across. Dual windshield washers too.

### Extra equipment



You can also order your Saab 96 with a sun roof or a Saxomat Automatic clutch at an extra charge.

### Saab 96

is one of the best-equipped cars on the market. Standard features include:

- self-cancelling directional indicators
- electric clock
- individually adjustable front seats—7 settings
- adjustable rear seat height
- foam rubber upholstery
- anti-theft lock
- complete set of tools



Body-frame unit rust-proofed and undercoated at factory.

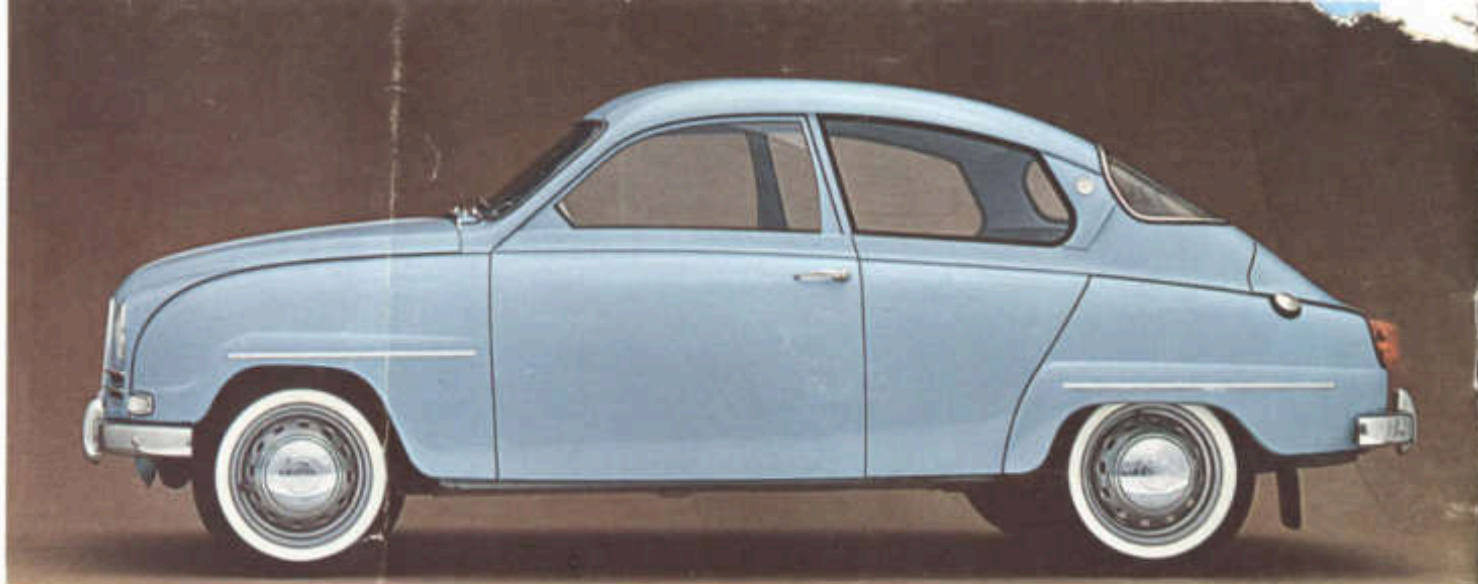
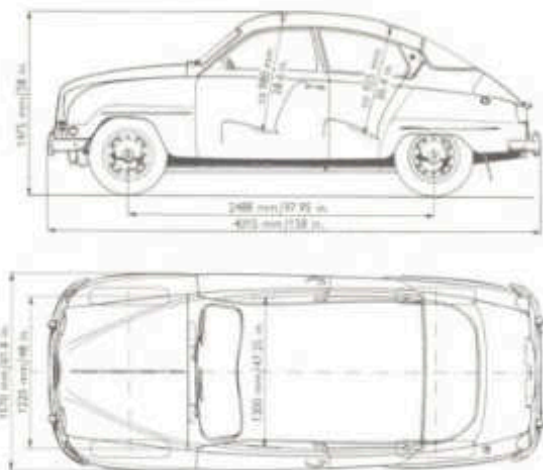

The five-seater Saab 96 sedan is visible proof that a safe, solidly built car can be both eminently practical and strikingly handsome.

## Technical data

### Engine

Three-cylinder, two-stroke. Bore 2.76 in. Stroke 2.87 in. Piston displacement 51.3 cu. in. Compression ratio 7.3:1. Max. horse power 42 BHP (SAE). Max. torque 61 lb-ft SAE at 2,800 r.p.m. Cooling system: Water cooling. Circulation pump, fan, thermostat. Cap. of system including heater, about 8 qt.

Fuel system: Electric pump, down-draft carburetor. Tank capacity about 10½ U.S. gal. Lubrication: Addition of 3% oil to fuel.

### Power train

Engine, clutch, gearbox, and differential are assembled as a unit, mounted between driving wheels. Front-wheel drive. Free-wheeling.

Clutch: Single, dry-disk, cushion-center. Saxomat automatic clutch available as an extra.

Standard gearbox: Three forward ratios and reverse. 2nd and 3rd speeds synchronized. Overall gear ratios Top 5.1:1, 2nd 8.5:1, 1st 16.7:1, reverse 21.0:1.

4-speed gearbox, available at extra cost: All forward speeds synchronized. Overall gear ratios Top 4.6:1, 3rd 7.0:1, 2nd 11.4:1, 1st 19.3:1, reverse 17.6:1.

Steering column gear shift lever.

Differential: Gear ratio 5.43:1. Gearbox and differential (same housing) take about 1.5 qts. of oil. At an engine speed of 1,000 r.p.m. in top gear with wheel radius of 11.9 in., road speed is 13.5 m.p.h.

### Brakes

Lockheed hydraulic foot brakes. Lining: 9" × 1½" front, 8" × 1½" rear. Total area 105 sq. in. Mechanical hand brake, acting on rear wheels. A pressure-reduction valve prevents the rear wheels from locking prematurely.

### Steering

Rock-and-pinion. Mean overall reduction, 14:1. No. of steering wheel turns from hard over left to hard over right, 2½.

### Suspension

All wheels have individual coil springs and direct-acting telescopic shock absorbers. Independent front wheel suspension with wishbones. U-formed, tubular, rigid rear axle.

### Wheels and tires

Wide base artillery wheels, 4J × 15". Tubeless tires, 5.00—5.20 × 15".

### Electrical system

12-volt, 33 amp. hr. battery. 0.5 hp starting motor. 160 watt generator. Vacuum-operated spark control. Pick-proof ignition lock. Extra-sturdy armored cable from ignition lock to ignition coil. 12 8-amp. fuses.

### Body-frame unit

Unit construction. Two doors. Rustproofing and undercoating applied at factory. Trunk at rear; cap. 13 cu. ft.

### Dimensions

Overall length (including bumpers) . . . . .	158 in.
Overall width . . . . .	62 in.
Overall height (empty) . . . . .	58 in.
Road clearance (two passengers in front) . . . . .	7.5 in.
Track, front and rear . . . . .	48 in.
Wheelbase . . . . .	98 in.
Turning radius . . . . .	18 ft.

### Weights

Curb weight (including fuel, water, tools, spare wheel): approx. 1790 lb. 58 per cent of curb weight is on front wheels.

### Standard equipment

Sealed beam headlights, lighting in trunk, self-cancelling direction indicators, dual windshield wipers, two padded sun visors, windshield washers, theftproof lock, ashtrays on instrument panel and at rear seat, space for radio, glove compartment with lock, dual horns, thermostatically controlled heater-ventilator-defroster with cowl intake and discharge behind rear side windows, undercoating, foam rubber upholstery, adjustable back lounge seats (7 positions). Safety padding on top of instrument panel.

In addition to controls, instrument panel has Ribbon type speedometer, coolant thermometer, fuel gauge, ammeter, electric clock, and indicator lamps for direction-indicators and for headlight high beam. Courtesy light. Warning light shows when level in fuel tank falls below 13 qt. Spare wheel with tire, jack, tool kit.

Svenska Aeroplan Aktiebolaget reserves the right to change above specifications at any time and without notice.

## SVENSKA AEROPLAN AKTIEBOLAGET



Works TROLLHÄTTAN

Export Department LINKÖPING

SWEDEN