

2019 Mirai



 Let's
Go
Places

LIFESTYLE



Don't just dream of a better world. Make it. The 2019 Mirai.

The innovative Mirai Fuel Cell Electric Vehicle (FCEV) is one daring statement crafted to help shape the next generation of mobility. Mirai literally means "future," and its advanced innovations go well beyond its hydrogen-powered fuel cell system. Engineers worked tirelessly to push the boundaries of hydrogen technology, doing everything from inventing a new way to weave carbon fiber to helping create the SAE standards used across modern hydrogen fueling stations. This investment in hydrogen is an investment in sustainable mobility for all.

Mirai shown in Salsa Red Pearl. Prototype shown.

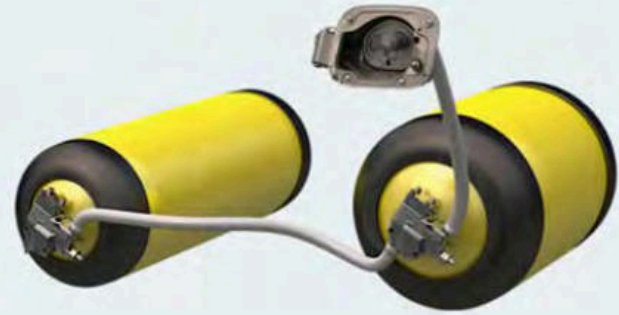
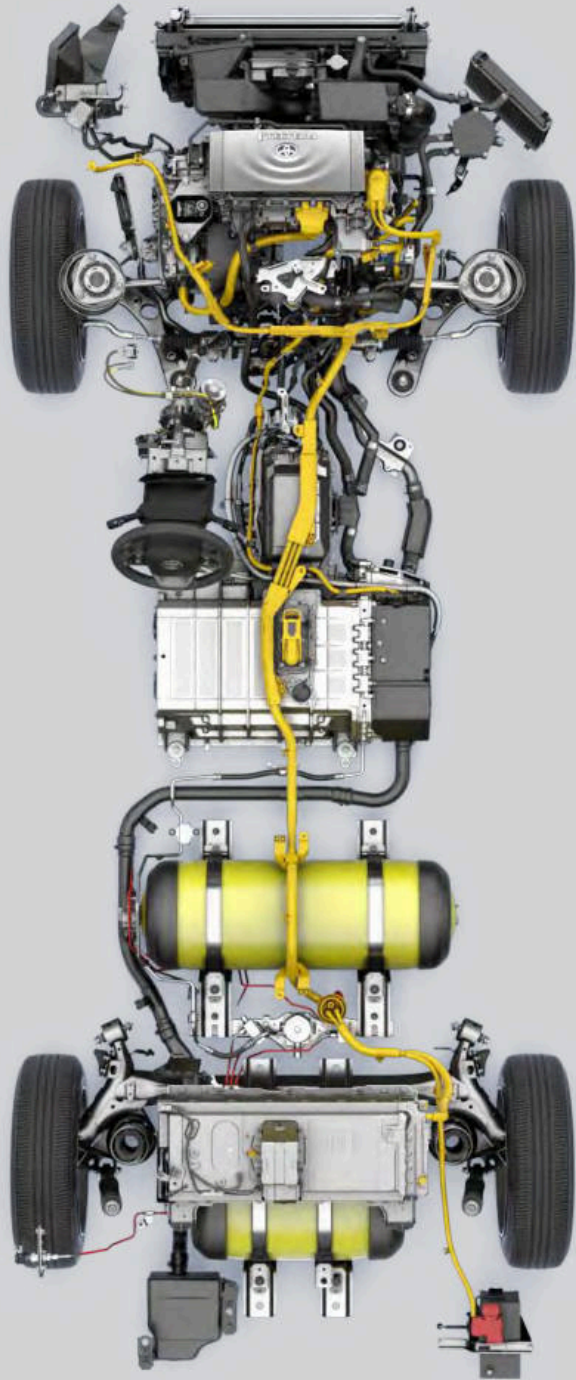

“We had to create our own carbon-fiber wrapping process, which increased the speed of wrapping over six times from our previous method — far faster than anything available in the rest of the industry at the time of development. It shouldn’t be too surprising that our automotive engineers could shift gears and develop this new method, given Toyota’s origination as a loom company.”

— Jackie Birdsall, Senior Engineer,
Toyota Motor North America



How it works

The Power Control Unit (PCU) decides when to use stored energy from the battery or to draw energy directly from the fuel cell system. This is part of what makes Mirai so energy efficient, and is based on the proven Toyota hybrid PCU found in Prius.



THE MOTOR

We utilized our in-house, technological know-how to select the right electric motor for Mirai. This motor has been rigorously tested across all types of environments and conditions, and delivers the reliability you expect from Toyota.

THE BOOST CONVERTER

Our four-phase boost converter brings voltage to 650 volts. Driving at a higher voltage makes more efficient use of the motor, giving Mirai a power output equivalent to other hybrids in Toyota's portfolio.



The fuel cell system

The fuel cell system generates power by combining hydrogen with oxygen from the outside air. Toyota has helped lead the industry in this fuel cell system efficiency, achieving a high power output from a relatively compact system.

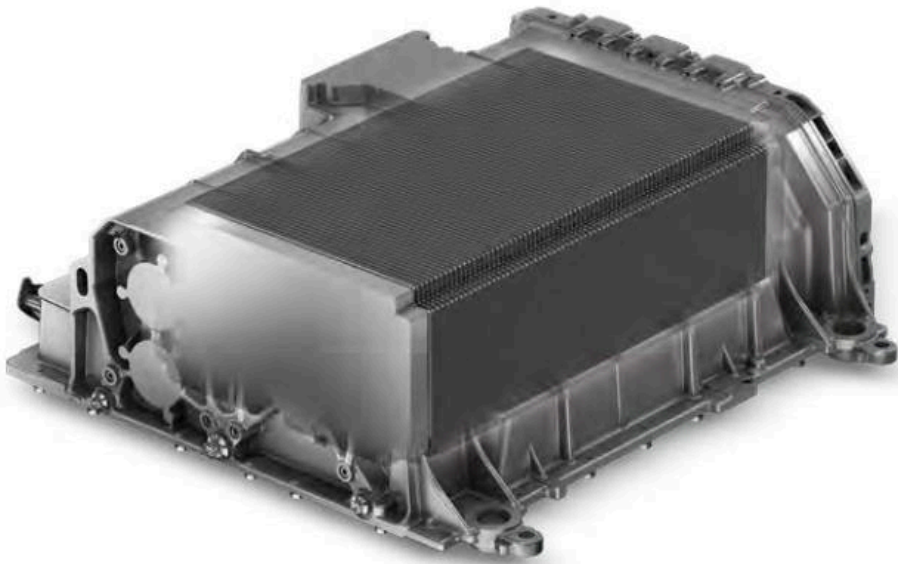

THE BATTERY

The battery allows for regenerative braking and also assists during high-power demands like accelerating — improving total system efficiency and fuel economy. Like the motor, the battery is sourced from proven Toyota hybrid technology.

THE HYDROGEN TANKS

All of our hydrogen tanks are produced in-house and specially designed for Mirai. Toyota's history in the loom-weaving business helped our engineers design the carbon-fiber weaving on our tanks, improving production efficiencies and helping to optimize the weight-to-storage ratio.



“As of today, Toyota solely owns approximately 5,680 hydrogen-fuel-cell-related global patents. Approximately 1,970 licenses are related to the fuel cell stack, about 290 to the high-pressure hydrogen tank and about 3,350 to fuel cell system control technology.”

— Bob Carter, EVP of Sales,
Toyota Motor North America



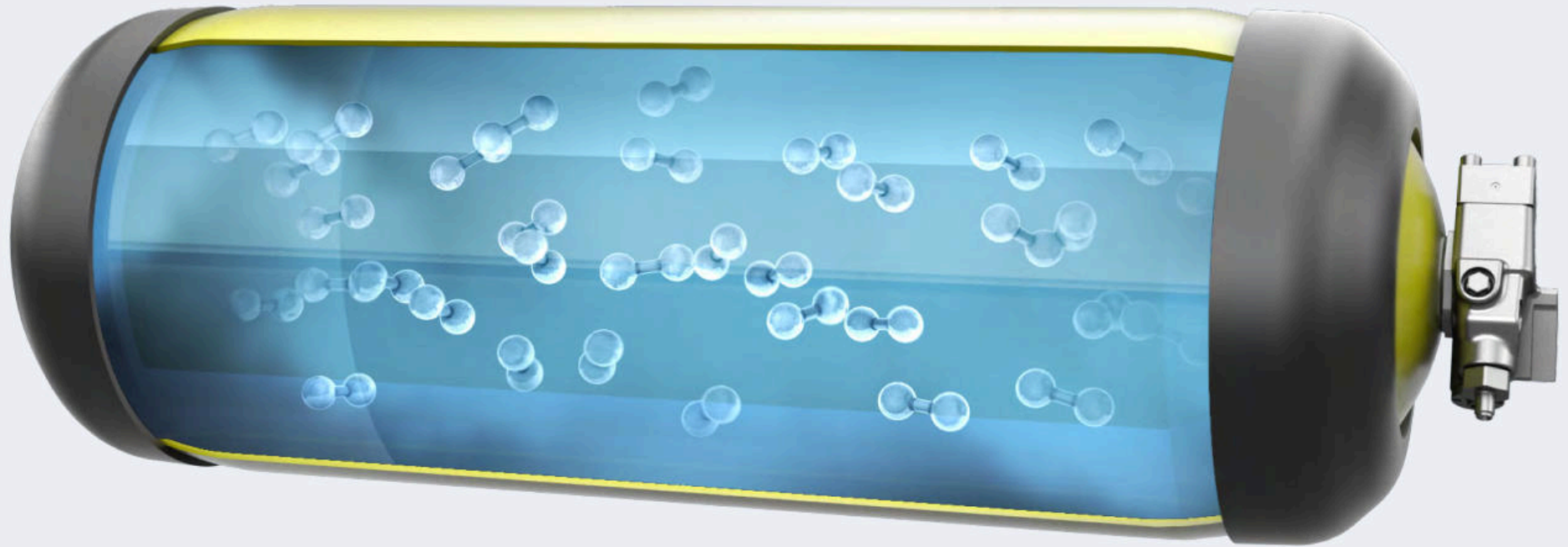

Fuel a more sustainable tomorrow.

With our Environmental Challenge 2050, Toyota aims to go beyond zero environmental impact and achieve a net positive impact. One pillar of this challenge is to reduce vehicle CO₂ emissions by 90 percent compared to 2010 levels, and one of the key ways to achieve this goal will be through the utilization of hydrogen as a fuel source. Wider adoption of hydrogen-powered fuel cell electric vehicles could lead to reduced emissions of greenhouse gases, helping to create a better environment for all.

Hydrogen is fuel. Pure and simple.

There are a lot of ways to produce hydrogen. But hydrogen binds to almost anything, so before it can be used, it must be separated. A variety of process technologies are available today, like steam reforming, electrolysis and gasification.



STEAM REFORMING

Steam reforming of methane is the most common method for producing hydrogen today. It starts with liquids or gases containing hydrogen, like natural gas or sustainable biogas sourced from landfills. The fuel then reacts with steam at high temperatures in a reformer, leaving you with hydrogen.



ELECTROLYSIS

Hydrogen can also be produced by separating water into its two primary elements — hydrogen (H_2) and oxygen (O_2). This process, known as electrolysis, passes an electrical current through the water to extract hydrogen. The electricity can be sourced from clean, renewable energy such as wind, solar or hydro.



GASIFICATION

Gasification is a process in which organic materials, like crops and livestock waste, are converted into hydrogen. The organic materials are placed under high temperatures, which trigger a reaction that separates the hydrogen.

You already know how to fill up.

Refueling a Mirai isn't complicated. There's a pump and a nozzle, just like at a gasoline station. After about five minutes,⁴⁵ you'll be ready to drive an EPA-estimated 312 miles.⁴⁷

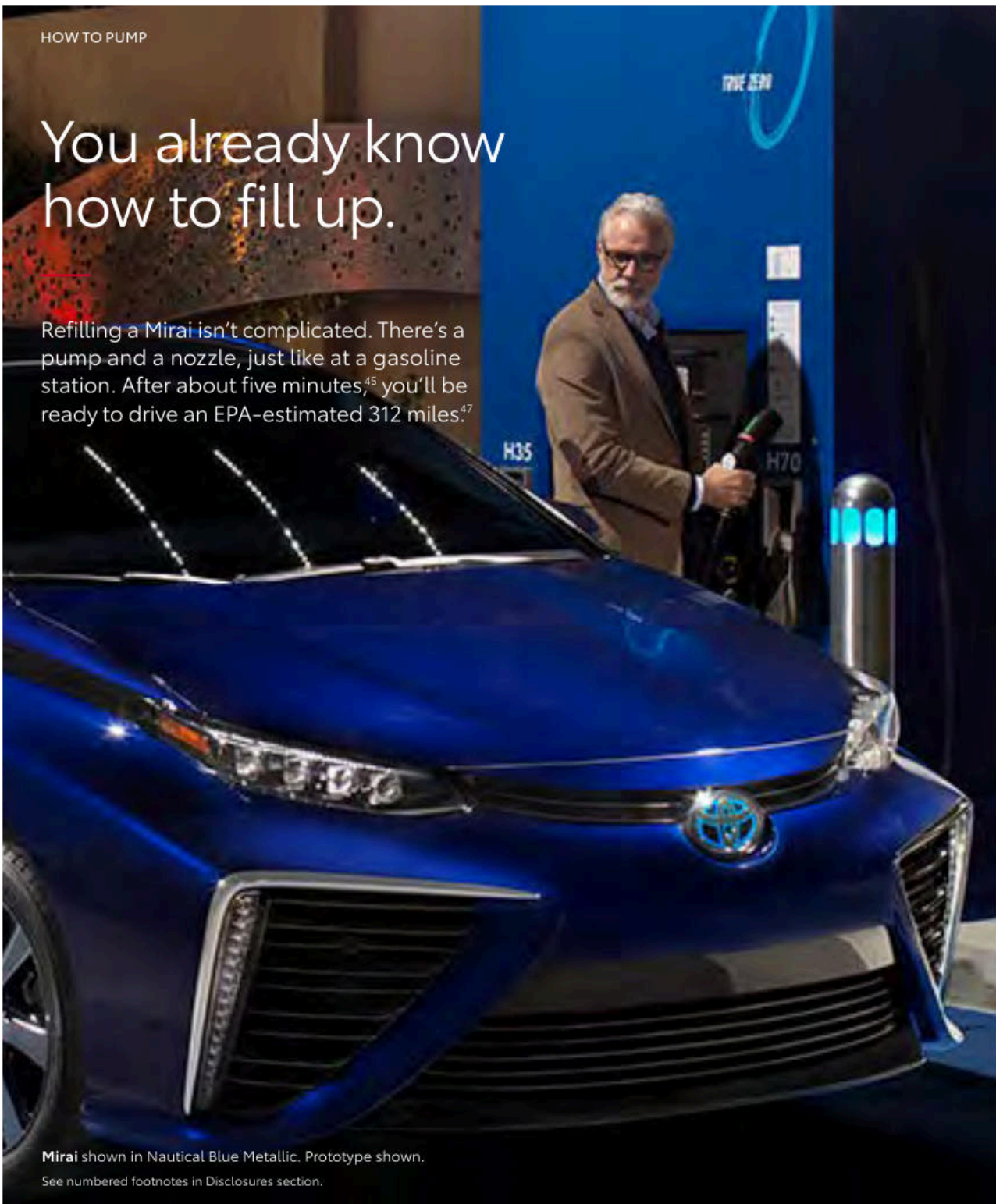

Mirai shown in Nautical Blue Metallic. Prototype shown.
See numbered footnotes in Disclosures section.

STEP #1

Place the nozzle over the receptacle, creating a secure connection. Unlike gasoline pumps, hydrogen nozzles have a barrel that fits over the car receptacle.



STEP #2

Squeeze the handgrip latch to lock the nozzle into place. The pump will not start until the nozzle is properly engaged, preventing any hydrogen from leaking.

STEP #3

Let the computer top it off. During fueling, Mirai's hydrogen fuel control computer disables the vehicle and communicates with the station pump, allowing the vehicle to fill up safely and efficiently.



STEP #4

Wait for the click to let you know fueling is complete. When complete, pull up the handgrip latch to unlock the nozzle and return it to the holder.

Rethinking the fuel tank.

It all starts with hydrogen. When you pump hydrogen into the vehicle, it travels to carbon-fiber-reinforced fuel tanks where it's stored. A vehicle as groundbreaking and revolutionary as the hydrogen-fueled Toyota Mirai is coupled with equally groundbreaking and revolutionary technology.

1. **Inner:** polymer-lined layer to hold the hydrogen
2. **Middle:** structural layer of carbon-fiber-reinforced polymer to provide strength
3. **Outer:** fiber-glass reinforced polymer layer to help protect from surface abrasions

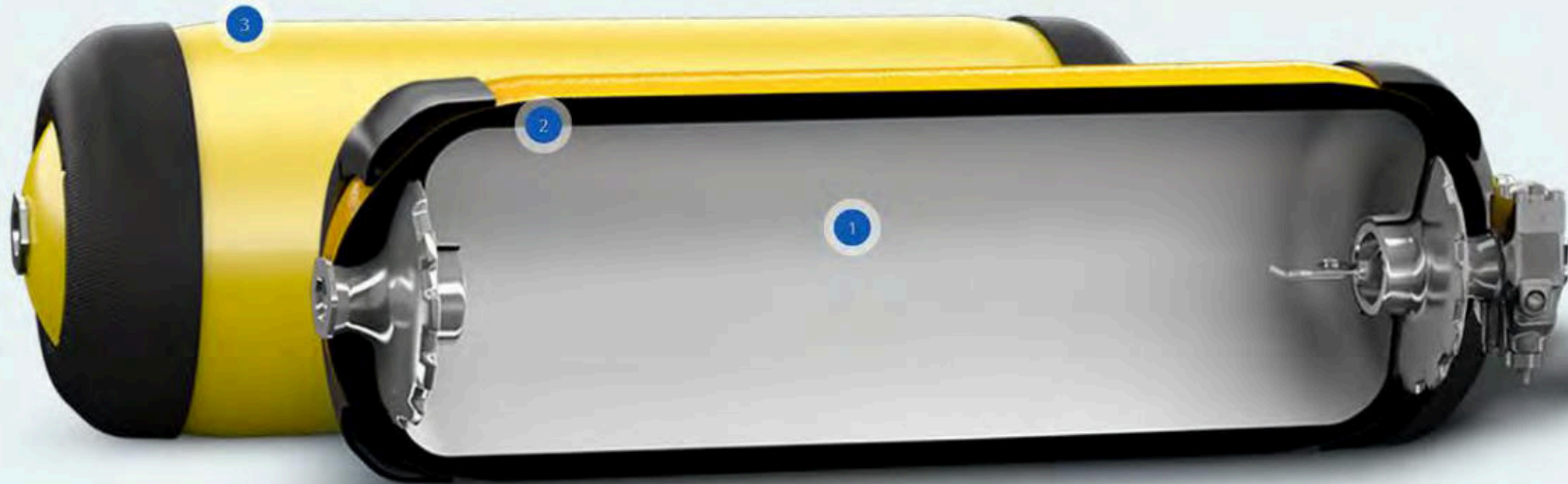
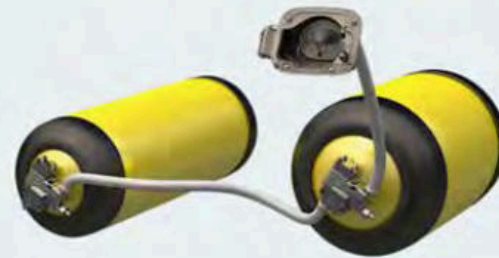

Buying into clean energy doesn't mean buying into the unknown.

As with Prius, we proved that alternative-fuel vehicles can be mainstream as well as fashionable. Now we're doing the same with Mirai. Toyota engineers have spent decades developing Mirai's fuel cell powertrain to deliver the quality, reliability and dependability expected from Toyota. This means that Mirai operates just like a regular passenger car, while creating zero emissions. Since its hydrogen fuel can be created from renewable resources like solar, wind and biowaste, Mirai is helping to usher in a new era powered by clean energy.



FIRST COMES AIR

The FCEV's front intake grilles deliver the outside air to the fuel cell system.



WHICH MAKES ELECTRICITY

Hydrogen travels from the tanks to the fuel cell system. In the fuel cell system, hydrogen and oxygen from the air combine in a chemical reaction that creates electricity to power the vehicle.



MOVING YOU FORWARD

When you put your foot on the accelerator, electricity from the fuel cell system is sent to the motor.



LEAVING NOTHING BUT WATER

In the end, the only by-product of creating electricity with hydrogen and oxygen in our fuel cell system is water, which leaves through a hatch located on the bottom of Mirai.

A global effort. Committed to safety.

Global Technical Regulation No.13 is an agreement between Japan, Europe and North America that sets the safety requirements that all high-pressure hydrogen systems must adhere to. Compliance with this regulation is tough, and requires hydrogen tanks to be dropped, frozen, damaged, exposed to chemicals, hydraulically and pneumatically cycled, stuck on a bonfire and ultimately burst to ensure tank performance throughout the lifetime of the vehicle. Toyota engineers have worked to ensure that Mirai's hydrogen tanks meet these regulations so that drivers may enjoy years of emission-free driving.

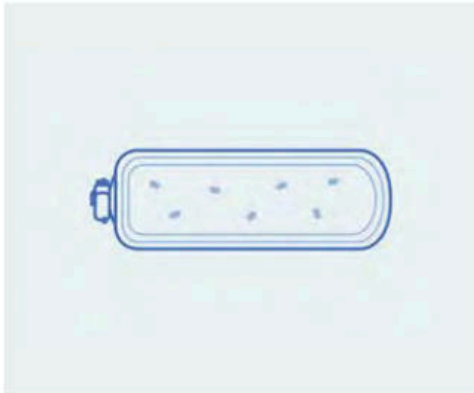

OUR TANKS ARE DESIGNED NOT TO LEAK

Our multi-patented, carbon-fiber-wrapped, polymer-lined tanks are built in a three-layer structure and absorb five times the crash energy of steel.



IN A HIGH-SPEED COLLISION, SENSORS STOP THE FLOW OF HYDROGEN

To prevent hydrogen from traveling to potentially damaged systems outside of the tank, the system is designed to automatically shut off the tank's hydrogen output valve.



ANY LEAKED HYDROGEN IS QUICKLY DISPERSED

All hydrogen-related parts are located outside the cabin and are designed to help prevent leaked hydrogen from building up.



HYDROGEN ESCAPES SAFELY INTO THE ATMOSPHERE

Since hydrogen is lighter than air, it rapidly disperses, reducing the time to cause damage in the event of an ignition.



FRONT AND REAR PARKING ASSIST SONAR⁴³

Tech that helps you see what you may not. When parking, sonar sensors on the front and rear of Mirai scan for walls, curbs and other objects that might be hidden from your view. Audio and visual cues are sent to the cabin, helping to take some of the guesswork out of parking.

Mirai shown in Salsa Red Pearl and Nautical Blue Metallic. Prototypes shown.

See numbered footnotes in Disclosures section.



Designed for safety.

Toyota Safety Sense™ 2.0 (TSS 2.0)³⁰ is a bundle of active safety features standard on every 2019 Mirai. These innovative features were designed to help protect you and your passengers from harm.



PRE-COLLISION SYSTEM³¹ WITH PEDESTRIAN DETECTION³²

Pre-Collision System with Pedestrian Detection (PCS w/PD) helps keep the road safe by detecting a vehicle, pedestrian or bicyclist in certain situations. The latest system has enhanced low-light capabilities to help detect a pedestrian at night. By combining millimeter-wave radar with a camera capable of shape recognition, the system provides an audio/visual alert, warning you of a possible collision under certain circumstances. If you don't react, the system is designed for automatic braking support to help mitigate the potential for a collision.

See numbered footnotes in Disclosures section.

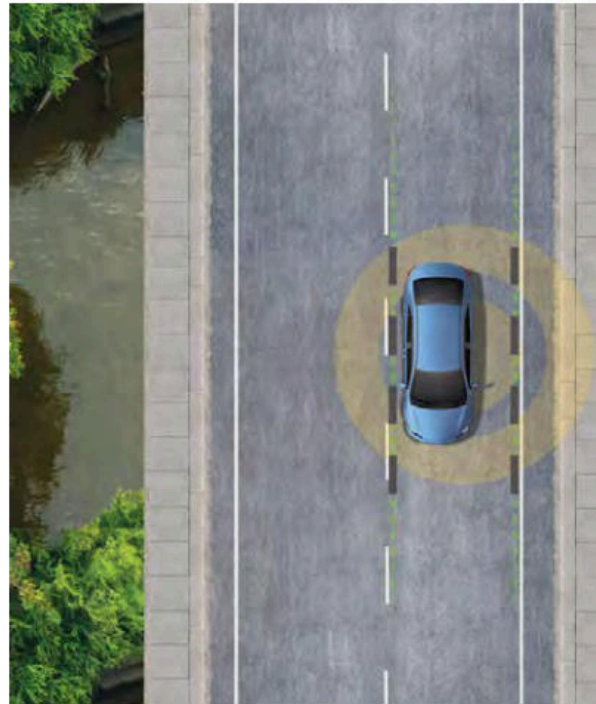

LANE DEPARTURE ALERT WITH STEERING ASSIST²⁴ AND ROAD EDGE DETECTION

Using Road Edge Detection or by detecting visible lane markings, the Lane Departure Alert with Steering Assist (LDA w/SA) issues both an audible alert and visual warning on the MID screen if an inadvertent lane departure is detected. If the system determines that the driver is not taking corrective steering action, the Steering Assist function is designed to initiate and provide gentle corrective steering to help keep Mirai in the lane.

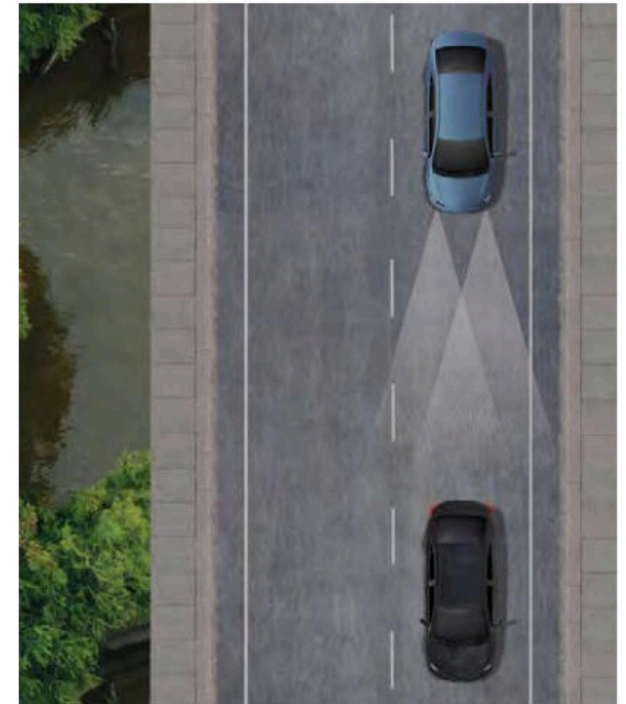

AUTOMATIC HIGH BEAMS²

Automatic High Beams (AHB) are a safety system designed to help you see more clearly at night — without distracting other drivers. Designed to activate at speeds above 25 mph, AHB rely on an in-vehicle camera to help detect the headlights of oncoming vehicles and taillights of preceding vehicles, then automatically toggle between high and low beams accordingly to provide the appropriate amount of light. By using high beams more frequently, the system may allow earlier detection of pedestrians and obstacles.



DYNAMIC RADAR CRUISE CONTROL²⁶

Intended for highways and similar to “constant speed” cruise control, Dynamic Radar Cruise Control (DRCC) lets you drive at a preset speed. DRCC uses vehicle-to-vehicle distance control, which is designed to adjust your speed, to help you maintain a preset distance from vehicles ahead of you that are driving at a slower speed. DRCC uses a front-grille-mounted radar and an in-vehicle camera designed to detect vehicles and their distance. If a driver is traveling slower than you, or within your preset range, DRCC is designed to automatically slow your vehicle down without deactivating cruise control. If DRCC determines you need to slow down more, an audio and visual alert notifies you and brakes may be applied. When there’s no longer a vehicle driving slower than your preset speed in front of you, DRCC will then accelerate and regular cruise control will resume.

See numbered footnotes in Disclosures section.

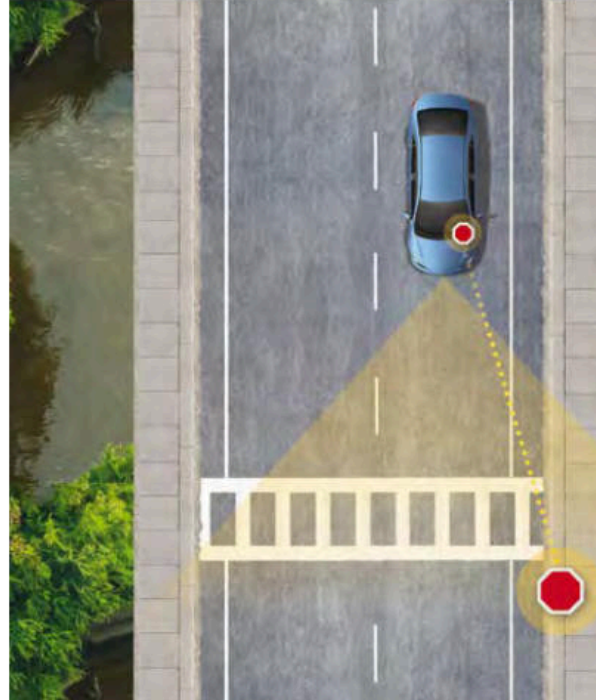

ROAD SIGN ASSIST³⁴

Mirai’s Road Sign Assist (RSA) helps keep the road safe. Using a forward-facing intelligent camera, Road Sign Assist is designed to detect speed limit signs, stop signs and yield signs, and displays them on the MID.



One comprehensive benefits package.

The Mirai experience includes a number of exceptional services, including ToyotaCare⁵⁰ with three years of no cost enhanced roadside assistance,⁴¹ regardless of mileage. Also included is a Complimentary Rental Experience, with use of a rental Toyota for up to 21 days within three years.⁵¹ An 8-year/100,000-mile warranty of the fuel cell components helps to ensure that this FCEV is ready to go the distance. And with 3 years or up to \$15,000 worth of complimentary fuel,⁵² Mirai makes it even easier to embrace sustainability.

Learn more at: Toyota.com/Mirai/Pricing

Contact your nearest dealer at: Toyota.com/Mirai/Contact

Mirai shown in Nautical Blue Metallic and Salsa Red Pearl. Prototypes shown.

See numbered footnotes in Disclosures section.



Exterior Features

- LED low- and high-beam headlights with Automatic High Beams (AHB)² with auto on/off feature
- LED Daytime Running Lights (DRL)
- LED stop lights
- Black sport front grille
- Exclusive fuel cell vehicle badging
- Color-keyed heated power auto-dimming outside mirrors with turn signal and blind spot warning indicators,³ reverse tilt and power-folding features with 2-position memory function
- Color-keyed outside door handles (with touch-sensor lock/unlock feature on front doors)
- 17-in. silver-painted, machined, engraved alloy wheels with black-painted accents and P215/55R17 tires
- Rain-sensing, washer-linked, variable intermittent windshield wiper with heated windshield wiper de-icer
- Acoustic noise-reducing windshield and front/rear side glass

Interior Features

- Dual zone automatic climate control with Intelligent Touch controls, cabin air filter and individually controlled rear-seat vents
- Intelligent Touch controls for heated seats, heated steering wheel and windshield wiper de-icer
- Entune™ 3.0^{4,5} Premium Audio with JBL⁶ w/Clari-Fi⁷ Dynamic Navigation⁷ and App Suite^{4,5} — includes 11 speakers including subwoofer, amplifier, 7-in. touch-screen, AM/FM CD player, MP3/WMA playback capability, auxiliary port, USB 2.0 port⁸ with iPod^{8,9} connectivity and control, Dynamic Navigation⁷ with up to a 3-year trial,¹⁰ Dynamic POI Search, Dynamic Voice Recognition,¹¹ hands-free phone capability and music streaming¹² via Bluetooth^{6,12} wireless technology, Entune⁹ App Suite^{4,5} Siri⁹ Eyes Free,¹³ HD Radio¹⁴ Technology, SiriusXM⁹ Satellite Radio¹⁵ with 3-month complimentary All Access trial¹⁶ and Gracenote⁹ album cover art. Toyota Connected Services — Safety Connect^{9,17} with 3-year trial,¹⁸ Wi-Fi Connect Powered by Verizon¹⁹ with up to 2GB within 6-month trial²⁰ and Destination Assist Connect²¹ with 6-month trial.²² See toyota.com/entune for details.
- Integrated backup camera²³ display with projected path
- TFT Multi-Information Display (MID), trip performance score, fuel consumption history, average fuel economy, fuel economy history, fuel cell system power level, Lane Departure Alert (LDA)²⁴ clock settings, trip history
- Water release control

Interior Features (cont.)

- SofTex²⁵-trimmed two-stage heated front seats with contrasting inserts and seatback pockets; 8-way power-adjustable driver's seat with 2-position memory function and power lumbar support; 8-way power adjustable front passenger seat with power lumbar support
- SofTex²⁵-trimmed two-stage heated rear seats
- Smart Key System²⁷ on front doors and trunk with Push Button Start and remote illuminated entry
- Power door locks with shift-linked automatic lock/unlock feature and anti-lockout feature
- Multi-function front seat center console with carbon-fiber-style accents, sliding cover and armrest, two front cup holders, Qi-compatible wireless smartphone charging;²⁹ USB 2.0 port⁸ with iPod^{8,9} connectivity and control
- One 12V rear auxiliary power outlet and two USB 2.1A charging ports⁸
- Four cup holders and two front bottle holders

Safety Features

- Toyota Safety Sense™ 2.0 (TSS 2.0)³⁰ — Pre-Collision System³¹ with Pedestrian Detection³² (PCS w/PD) with cyclist detection and improved low-light capabilities, Lane Departure Alert with Steering Assist (LDA w/SA)²⁴ and Road Edge Detection, Sway Warning System (SWS),³³ Automatic High Beams (AHB),² Dynamic Radar Cruise Control (DRCC),²⁶ Road Sign Assist (RSA)³⁴
- Star Safety System™ — includes Vehicle Stability Control (VSC),³⁵ Traction Control (TRAC), Anti-lock Brake System (ABS), Electronic Brake-force Distribution (EBD), Brake Assist (BA)³⁶ and Smart Stop Technology⁹ (SST)³⁷
- Eight airbags³⁸ — includes driver and front passenger Advanced Airbag System, driver and front passenger seat-mounted side airbags, driver knee airbag, passenger seat-cushion airbag, and front and rear side curtain airbags
- LATCH (Lower Anchors and Tethers for Children) includes lower anchors and upper tether anchors on rear seats
- Child-protector rear door locks
- Energy-absorbing collapsible steering column
- Front and rear energy-absorbing crumple zones
- Tire Pressure Monitor System (TPMS)³⁹
- Collision sensors: deactivate high-voltage battery and close H₂ tank valves
- Vehicle Proximity Notification System (VPNS)⁴⁰
- Safety Connect^{9,17} — includes Emergency Assistance, Stolen Vehicle Locator, Roadside Assistance⁴¹ and Automatic Collision Notification; with three-year trial subscription.
- Blind Spot Monitor (BSM)³ and Rear Cross-Traffic Alert (RCTA)⁴²
- Front and rear parking assist sonar⁴³
- LED Daytime Running Lights (DRL) with on/off feature
- Anti-theft system with engine immobilizer⁴⁴

Color

Celestial Black⁵³

Nautical Blue Metallic



Atmospheric Blue Metallic

Salsa Red Pearl

Elemental Silver⁵³Crystal White⁵³

Trim

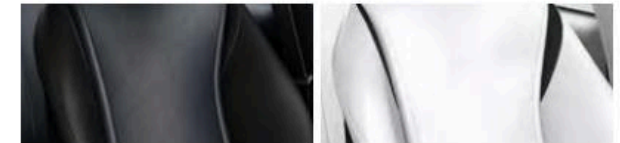

Deep Ocean Blue

Warm White

Wheel



17-in. engraved alloy wheel

FEATURES¹

	Mirai
EXTERIOR	
LED low- and high-beam headlights with Automatic High Beams (AHB) ² with auto on/off feature	S
LED Daytime Running Lights (DRL)	S
LED stop lights	S
Black sport front grille	S
Color-keyed front bumpers with black inserts with chrome accents and color-keyed rear bumpers	S
Exclusive fuel cell vehicle badging	S
Color-keyed heated power auto-dimming outside mirrors with turn signal and blind spot warning indicators ³ reverse tilt and power-folding features with 2-position memory function	S
Color-keyed outside door handles (with touch-sensor lock/unlock feature on front doors)	S
17-in. silver-painted, machined, engraved alloy wheels with black-painted accents and P215/55R17 tires	S
Rain-sensing, washer-linked, variable intermittent windshield wiper with heated windshield wiper de-icer	S
Acoustic noise-reducing windshield and front/rear side glass	S
Color-keyed roof-mounted shark-fin antenna	S
INTERIOR	
Dual zone automatic climate control with Intelligent Touch controls, cabin air filter and individually controlled rear-seat vents	S
Intelligent Touch controls for heated seats, heated steering wheel and windshield wiper de-icer	S
Entune™ 3.0 ^{4,5} Premium Audio with JBL ^{®6} w/Clari-Fi™ ⁶ Dynamic Navigation ⁷ and App Suite ^{4,5} — includes 11 speakers including subwoofer, amplifier, 7-in. touch-screen, AM/FM CD player, MP3/WMA playback capability, auxiliary port, USB 2.0 port ⁸ with iPod ^{®9} connectivity and control, Dynamic Navigation ⁷ with up to a 3-year trial ¹⁰ Dynamic POI Search, Dynamic Voice Recognition, ¹¹ hands-free phone capability and music streaming ¹² via Bluetooth ^{®12} wireless technology, Siri [®] Eyes Free, ¹³ HD Radio™ ¹⁴ Technology, SiriusXM [®] Satellite Radio ¹⁵ with 3-month complimentary All Access trial ¹⁶ and Gracenote [®] album cover art. Toyota Connected Services — Safety Connect ^{®17} with 3-year trial, ¹⁸ Wi-Fi Connect Powered by Verizon ¹⁹ with up to 2GB within 6-month trial ²⁰ and Destination Assist Connect ²¹ with 6-month trial. ²² See toyota.com/entune for details.	S
Integrated backup camera ²³ display with projected path	S
TFT Multi-Information Display (MID), trip performance score, fuel consumption history, average fuel economy, fuel economy history, fuel cell system power level, Lane Departure Alert (LDA) ²⁴ clock settings, trip history	S
SofTex ^{®25} -trimmed heated tilt/telescopic steering wheel with 2-position memory function with piano-black accents and controls for audio, Multi-Information Display (MID), Bluetooth ^{®12} hands-free phone, voice command, Lane Departure Alert (LDA) ²⁴ and Dynamic Radar Cruise Control (DRCC) ²⁶	S
Water release control	S
Piano-black shift lever with matte-silver accents	S
TFT Display with speedometer, odometer, two tripmeters, current trip information, outside temp, fuel level indicator, MPGe, ECO Driving Indicator, fuel cell system power level and battery charge indicator (also see Multi-Information Display)	S
SofTex ^{®25} -trimmed two-stage heated front seats with contrasting inserts and seatback pockets; 8-way power-adjustable driver's seat with 2-position memory function and power lumbar support; 8-way power adjustable front passenger seat with power lumbar support	S
SofTex ^{®25} -trimmed two-stage heated rear seats	S
Rear seat with center console and armrest cup holders	S
Piano-black interior trim with carbon-fiber-style and matte-silver interior accents and chrome door handles	S
Smart Key System ²⁷ on front doors and trunk with Push Button Start and remote illuminated entry	S
Power windows with auto up/down and jam protection in all positions and retained-power features	S
Rear window defogger with timer	S
Power door locks with shift-linked automatic lock/unlock feature and anti-lockout feature	S
Frameless auto-dimming day/night rearview mirror with HomeLink ^{®28} universal transceiver	S
Multi-function front-seat center console with carbon-fiber-style accents, sliding cover and armrest, two front cup holders, Qi-compatible wireless smartphone charging; ²⁹ USB 2.0 port ⁸ with iPod ^{®9} connectivity and control	S
Covered rear-seat center console with tilt open and armrest, storage compartment and two cup holders	S
Passenger-side lockable glove compartment	S
One 12V rear auxiliary power outlet and two USB 2.1A charging ports ⁸	S
Dual extendable sun visors with sliding extensions and illuminated vanity mirrors	S
Overhead console with maplights and dome light, sunglasses storage, Safety Connect ^{®17} button	S
Front and rear dome lights, front maplights (reading lights)	S
Four cup holders and two front bottle holders	S

See numbered footnotes in Disclosures section.

S = Standard

FEATURES¹ (continued)

SAFETY/CONVENIENCE

	Mirai
Toyota Safety Sense™ 2.0 (TSS 2.0) ³⁰ — Pre-Collision System ³¹ with Pedestrian Detection ³² (PCS w/PD) with cyclist detection and improved low-light capabilities, Lane Departure Alert with Steering Assist (LDA w/SA) ²⁴ and Road Edge Detection, Sway Warning System (SWS) ³³ Automatic High Beams (AHB) ² , Dynamic Radar Cruise Control (DRCC) ²⁶ , Road Sign Assist (RSA) ³⁴	S
Star Safety System™ — includes Vehicle Stability Control (VSC) ³⁵ Traction Control (TRAC), Anti-lock Brake System (ABS), Electronic Brake-force Distribution (EBD), Brake Assist (BA) ³⁶ and Smart Stop Technology® (SST) ³⁷	S
Eight airbags ³⁸ — includes driver and front passenger Advanced Airbag System, driver and front passenger seat-mounted side airbags, driver knee airbag, passenger seat-cushion airbag, and front and rear side curtain airbags	S
3-point seatbelts for all seating positions, driver-side Emergency Locking Retractor (ELR) and Automatic/Emergency Locking Retractor (ALR/ELR) on all passenger belts	S
Seatbelt pretensioners with force limiters for all seating positions	S
LATCH (Lower Anchors and Tethers for Children) includes lower anchors and upper tether anchors on rear seats	S
Child-protector rear door locks	S
Energy-absorbing collapsible steering column	S
Front and rear energy-absorbing crumple zones	S
Side-impact door beams	S
Tire Pressure Monitor System (TPMS) ³⁹	S
Collision sensors: deactivate high-voltage battery and close H ₂ tank valves	S
Vehicle Proximity Notification System (VPNS) ⁴⁰	S
Safety Connect® ¹⁷ — includes Emergency Assistance, Stolen Vehicle Locator, Roadside Assistance ⁴¹ and Automatic Collision Notification; with three-year trial subscription	S
Blind Spot Monitor (BSM) ³ and Rear Cross-Traffic Alert (RCTA) ⁴²	S
Front and rear parking assist sonar ⁴³	S
LED Daytime Running Lights (DRL) with on/off feature	S
Anti-theft system with engine immobilizer ⁴⁴	S

SPECIFICATIONS for Toyota Fuel Cell System

MECHANICAL/PERFORMANCE

	Mirai
NAME	
Toyota fuel cell system	S
TYPE	
Solid polymer electrolyte	S
HUMIDIFICATION METHOD	
Internal circulation form (humidifier-less)	S
MAX POWER OUTPUT	
153 hp	S
POWER DENSITY BY VOLUME	
3.1 kW/L	S
POWER DENSITY BY WEIGHT	
2.0 kW/kg	S
VOLUME	
37 liters	S
WEIGHT	
56 kg	S

MECHANICAL/PERFORMANCE (continued)

	Mirai
CELL	
Number of cells: 370	S
Cell thickness: 1.34mm	S
Cell weight: 102g	S
SEPARATOR MATERIAL	
Titanium	S
EMISSION RATING	
California Air Resources Board (CARB) Emission Standard: Zero Emissions Vehicle (ZEV)	S
Federal Environmental Protection Agency (EPA) Emission Standard: Tier 3 Bin 0	S

See numbered footnotes in Disclosures section.

S = Standard

HYDROGEN TANK	Mirai	WEIGHTS AND CAPACITIES	Mirai
STORAGE METHOD		Curb weight (lb.)	4075
High-pressure tanks (two)	S	Seating capacity	4
TYPE		Passenger volume (cu. ft.)	85.7
Type-4	S	Cargo volume ⁴⁶ (cu. ft.)	12.8
MAXIMUM FILLING PRESSURE		TIRES	
87.5 MPa	S	SIZE	
NORMAL OPERATIONAL PRESSURE		P255/55R17	S
70 MPa	S	DRIVE BATTERY	
STORAGE CAPACITY		TYPE	
5.7 wt%	S	Sealed Nickel-Metal Hydride (Ni-MH), 34 cell modules	S
SIZE (VOLUME)		POWER OUTPUT	
122.4L (fore tank: 60 liters, aft tank: 62.4 liters)	S	244.8 V (7.2 V x 34 cell modules)	S
MATERIAL		POWER ON-DEMAND SYSTEM	
Inner layer: polymer liner	S	MAX ELECTRICITY OUTPUT	
Middle layer: carbon-fiber-reinforced polymer	S	9 kW	S
Surface layer: fiber-glass-reinforced polymer	S	CRUISING RANGE	
REFUELING TIME⁴⁵		Approximately 300 miles ⁴⁷	S
Approximately 5 minutes	S	0-60	
ELECTRIC MOTOR		9.0 seconds	S
MOTOR TYPE		MPGE⁴⁷/OTHER	
Permanent Magnet AC synchronous	S	MPGe	67
MAXIMUM OUTPUT		Range (miles) ⁴⁷	312
151 hp	S	DRIVETRAIN	
TORQUE		Front-Wheel Drive	S
247 lb.-ft.	S	SUSPENSION	
DIMENSIONS		FRONT	
EXTERIOR DIMENSIONS (in.)		MacPherson strut	S
Overall height	60.5	REAR	
Overall width	71.5	Torsion beam	S
Overall length	192.5	STEERING	
Wheelbase	109.5	Electric Power Steering (EPS); power-assisted rack-and-pinion	S
Track (front/rear)	60.5/61	Turning circle diameter, curb to curb (ft.)	37.4
Minimum running ground clearance	5.1		
Coefficient of drag (Cd)	.29		
INTERIOR DIMENSIONS, FRONT/REAR (in.)			
Head room	38.5/36.8		
Shoulder room	54.3/53.52		
Hip room	53.4/52.4		
Leg room	42.5/30.1		
BRAKES			
Power-assisted ventilated front disc brakes; solid rear disc with integrated regenerative braking and Star Safety System™	S		

CARS BUILT FOR THE WAY YOU LIVE

At Toyota, we build cars for how you live. From building advanced safety features designed to help prevent crashes to driving cross-country to understand how we can make your driving experience better, our work starts with understanding your needs. Building cars for how you live also means thinking about tomorrow — from fuel efficiency and environmental innovations, to things beyond cars, like a bicycle that you can control with your mind. And because what we learn building cars can help improve lives in other places, we do things like help communities rebuild their homes quickly after a disaster and work with soup kitchens to help them serve more people faster. Toyota. Built for how you live. Together we are going places.

DISCLOSURES

1. Toyota strives to build vehicles to match customer interest and thus they typically are built with popular options and option packages. Not all options/packages are available separately and some may not be available in all regions of the country. See toyota.com for information about options/packages commonly available in your area. If you would prefer a vehicle without any or with different options, contact your dealer to check for current availability or the possibility of placing a special order. 2. Automatic High Beams operate at speeds above 25 mph. Factors such as a dirty windshield, weather, lighting and terrain limit effectiveness, requiring the driver to manually operate the high beams. See *Owner's Manual* for additional limitations and details. 3. Do not rely exclusively on the Blind Spot Monitor. Always look over your shoulder and use your turn signal. There are limitations to the function, detection and range of the monitor. See *Owner's Manual* for additional limitations and details. 4. Be sure to obey traffic regulations and maintain awareness of road and traffic conditions at all times. Apps/services vary by phone/carrier; functionality depends on many factors. Select apps use large amounts of data; you are responsible for charges. Apps and services subject to change at any time without notice. See toyota.com/entune for details. 5. If you register for Entune® App Suite and opt-in for Fuel Cell Electric Vehicle (FCEV) features, your vehicle will automatically and electronically transmit Vehicle Health Information to Toyota for quality confirmation, trend analysis, research, product development and to provide FCEV features to you. Transmission of Vehicle Health Information includes Diagnostic Trouble Codes (DTC) and related data from the vehicle's on-board diagnostic (OBD) system from your vehicle to Toyota without notice to you. Related data includes but is not limited to vehicle speed, FC system coolant temperature, air compressor revolution and FC output power. Vehicle Health Information may be used by Toyota for quality confirmation, trend analysis, research and product development and retained to achieve these goals. It is not shared outside of Toyota and is retained by Toyota to support research and development. Location data is used by Toyota to support hydrogen station map and vehicle finder applications operated by Toyota. At each ignition off, the location data overwrites the previous location data; the old data is purged. Toyota may share anonymized and aggregated fuel cell analytic reporting with federal and state regulatory agencies and non-profit organizations for the purpose of education and research related to environment and energy issues, advanced technology and usage analysis. 6. JBL® and Clari-Fi™ are registered trademarks of Harman International Industries, Incorporated. 7. Dynamic Navigation is dependent upon an operative telematics device, a cellular connection, navigation map data and GPS satellite signal reception, and other factors outside of Toyota's control, which can limit the ability or functionality of the system. To learn about Toyota Entune™ 3.0's data collection, use, sharing and retention, please visit <https://www.toyota.com/privacyvts/>. Use common sense when relying on information provided. Services and programming subject to change. Services not available in every city or roadway. Subscription required upon end of trial service period. See *Navigation System Owner's Manual* for additional details. 8. May not be compatible with all mobile phones, MP3/WMA players and like models. 9. iPod® and iPhone® are registered trademarks of Apple Inc. All rights reserved. 10. The Dynamic Navigation three-year trial begins the earlier of when the vehicle hits 100 miles or a year after the multimedia system manufacture date, regardless of when you purchase or lease the vehicle. Terms and conditions of subscription service agreement apply. 11. Dynamic voice recognition capabilities vary by head unit. 12. The Bluetooth® word mark and logos are registered trademarks owned by Bluetooth SIG, Inc., and any use of such marks by Toyota is under license. A compatible Bluetooth®-enabled phone must first be paired. Phone performance depends on software, coverage and carrier. 13. Always drive safely, obey traffic laws and focus on the road while driving. Siri® is available on select iPhone®/iPad® models and requires Internet access. Siri® is not available in all languages or all areas and features vary by area. Some Siri® functionality and commands are not accessible in the vehicle. Data charges may apply. See apple.com and phone carrier for details. Siri® is a registered trademark of Apple Inc. 14. HD Radio™ Technology manufactured under license from iBiquity Digital Corporation U.S. and Foreign Patents. HD Radio™ and the HD, HD Radio, and "Arc" logos are proprietary trademarks of iBiquity Digital Corp. 15. SiriusXM® audio services require a subscription sold separately by Sirius XM Radio Inc. If you decide to continue service after your trial, the subscription plan you choose will automatically renew thereafter and you will be charged according to your chosen payment method at then-current rates. Fees and taxes apply. To cancel, you must call SiriusXM at 1-866-635-2349. See SiriusXM Customer Agreement for complete terms at www.siriusxm.com. All fees and programming subject to change. Not all vehicles or devices are capable of receiving all services offered by SiriusXM. Current information and features may not be available in all locations, or on all receivers. ©2019 Sirius XM Radio Inc. SiriusXM and all related marks and logos are trademarks of Sirius XM Radio Inc. 16. Trial length and service availability may vary by model, model year or trim. 17. Toyota Safety Connect® is dependent upon an operative telematics device, a cellular connection and other factors outside of Toyota's control, which can limit the ability to reach the response center or receive emergency support or otherwise limit the functionality or availability of the system. Terms and conditions of subscription service agreement apply. To learn about Toyota's data collection, use, sharing and retention, please visit <https://www.toyota.com/privacyvts/>. Stolen vehicle police report required to use Stolen Vehicle Locator. 18. The Safety Connect® trial period is at no extra cost and begins on the original date of purchase or lease of a new vehicle. After the trial period expires, enrollment in paid subscription is required to access the service. Terms and conditions apply. 19. Verizon Wireless is the network provider for Wi-Fi Connect, which uses Verizon's 4G LTE network to transmit data. Data usage applies. Coverage not available everywhere; see vzw.com. See verizonwireless.com/bestnetwork for details. LTE is a trademark of ETSI. Other terms apply. Up to 5 devices can be supported using in-vehicle connectivity. Verizon Wireless data subscription required upon end of 6-month trial period or use of 2 GB data (whichever comes first). Use of Wi-Fi Connect subject to Verizon Wireless' Customer Agreement (verizonwireless.com/legal/notices/customer-agreement/), Privacy Policy (verizon.com/about/privacy/privacy-policy-summary), and data use policies (verizonwireless.com/support/vz-email-legal/). 20. The Wi-Fi Connect trial period is at no extra cost and begins on the date of activation. After the trial period expires, enrollment in a paid subscription is required to access the service. Terms and conditions apply. 21. Destination Assist Connect is dependent upon an operative telematics device, a cellular connection, navigation map data and GPS satellite signal reception, and other factors outside of Toyota's control, which can limit the ability or functionality of the system. Use common sense when relying on this information. To learn about Toyota Entune™ 3.0's data collection, use, sharing and retention, please visit <https://www.toyota.com/privacyvts/>. See *Owner's Manual* for additional details. 22. The Destination Assist Connect trial period is at no extra cost and begins on the original date of purchase or lease of a new vehicle. After the trial period expires, enrollment in a paid subscription is required to access the service. Terms and conditions of subscription service agreement apply. 23. The backup camera does not provide a comprehensive view of the rear area of the vehicle. You should also look around outside your vehicle and use your mirrors to confirm rearward clearance. Environmental conditions may limit effectiveness and view may become obscured. See *Owner's Manual* for additional limitations and details. 24. Lane Departure Alert with Steering Assist is designed to read visible lane markers under certain conditions. It provides a visual and audible alert, and slight steering force when lane departure is detected. It is not a collision-avoidance system or a substitute for safe and attentive driving. Effectiveness is dependent on many factors including road, weather and vehicle conditions. See *Owner's Manual* for additional limitations and details. 25. SofTex® is a registered trademark of Toyota Motor Sales, U.S.A., Inc. 26. Dynamic Radar Cruise Control is designed to assist the driver and is not a substitute for safe and attentive driving practices. System effectiveness is dependent on many factors including road, weather and traffic conditions. See *Owner's Manual* for additional limitations and details. 27. The Smart Key System may interfere with some pacemakers or cardiac defibrillators. If you have one of these medical devices, please talk to your doctor to see if you should deactivate this system. 28. HomeLink® and the HomeLink® house icon are registered trademarks of Gentex Corporation. 29. Qi wireless charging may not be compatible with all mobile phones, MP3/WMA players and like models. When using the wireless charging system, avoid placing metal objects between the wireless charger and the mobile device when charging is active. Doing so may cause metal objects to become hot and could cause burns. 30. Drivers are responsible for their own safe driving. Always pay attention to your surroundings and drive safely. System effectiveness is dependent on many factors including road, weather and vehicle conditions. See *Owner's Manual* for additional limitations and details. 31. The TSS Pre-Collision System is designed to help avoid or reduce the crash speed and damage in certain frontal collisions only. It is not a substitute for safe and attentive driving. System effectiveness is dependent on many factors including road, weather and vehicle conditions. See *Owner's Manual* for additional limitations and details. 32. The Pedestrian Detection system is designed to detect a pedestrian ahead of the vehicle, determine if impact is imminent and help reduce impact speed. It is not a substitute for safe and attentive driving. System effectiveness depends on many factors, such as speed, size and position of pedestrian, and weather, light and road conditions. See *Owner's Manual* for additional limitations and details. 33. Sway Warning is designed to provide a visual and audible alert if it detects a pattern of vehicle movement that might indicate driver inattention or drowsiness. It is not a collision-avoidance system or a substitute for safe and attentive driving. Effectiveness is dependent on many factors including road, weather and vehicle conditions. See *Owner's Manual* for additional limitations and details. 34. Do not rely exclusively on Road Sign Assist (RSA). RSA is a driver support system that utilizes the vehicle's forward-facing camera and navigation system to recognize certain road signs and provide information to the driver via the multi-information display and/or Head-Up Display. Effectiveness is dependent on road, weather, vehicle and sign conditions. Use common sense when using RSA and do not drive distracted. See *Owner's Manual* for additional limitations and details. 35. Vehicle

DISCLOSURES (continued)

Stability Control is an electronic system designed to help the driver maintain vehicle control under adverse conditions. It is not a substitute for safe and attentive driving practices. Factors including speed, road conditions, weather and driver steering input can all affect whether VSC will be effective in preventing a loss of control. See *Owner's Manual* for additional limitations and details. **36.** Brake Assist is designed to help the driver take full advantage of the benefits of ABS. It is not a substitute for safe driving practices. Braking effectiveness also depends on proper vehicle maintenance, and tire and road conditions. See *Owner's Manual* for additional limitations and details. **37.** Smart Stop Technology® operates only in the event of certain contemporaneous brake and accelerator pedal applications. When engaged, the system will reduce power to help the brakes bring the vehicle to a stop. Factors including speed, road conditions and driver input can all impact stopping distance. Smart Stop Technology® is not a substitute for safe and attentive driving and does not guarantee instant stopping. See *Owner's Manual* for additional limitations and details. **38.** All the airbag systems are Supplemental Restraint Systems. All airbags (if installed) are designed to inflate only under certain conditions and in certain types of severe collisions. To decrease the risk of injury from an inflating airbag, always wear seatbelts and sit upright in the middle of the seat as far back as possible. Do not put objects in front of an airbag or around the seatback. Do not use a rearward-facing child seat in any front passenger seat. See *Owner's Manual* for additional limitations and details. **39.** The Tire Pressure Monitor System alerts the driver when tire pressure is critically low. For optimal tire wear and performance, tire pressure should be checked regularly with a gauge; do not rely solely on the monitor system. See *Owner's Manual* for details. **40.** This device is not a substitute for safe and attentive driving practices. It is the driver's responsibility to maintain a lookout for pedestrians, cyclists, other cars and objects, and to drive the vehicle in a safe and attentive manner to avoid making contact. **41.** Roadside Assistance coverage is 3 years unlimited mileage. Does not include parts and fluids, except emergency fuel delivery. See Toyota Mirai Fuel Cell Electric Vehicle Dealership for details and exclusions. Valid only in the continental U.S. & Alaska. **42.** Do not rely exclusively on the Rear Cross-Traffic Alert system. Always look over your shoulder and use your mirrors to confirm rear clearance. There are limitations to the function, detection and range of the system. See *Owner's Manual* for additional limitations and details. **43.** Parking assist sonar is designed to warn drivers of potential front and rear collisions at speeds of 6 mph or less. Certain vehicle and environmental factors, including an object's shape and composition, may affect the ability of the front and rear parking assist sonar to detect it. Always look around outside the vehicle and use mirrors to confirm clearance. See *Owner's Manual* for additional limitations and details. **44.** The engine immobilizer is a state-of-the-art anti-theft system. When you insert your key into the ignition switch or bring a Smart Key fob into the vehicle, the key transmits an electronic code to the vehicle. The engine will only start if the code in the transponder chip inside the key/fob matches the code in the vehicle's immobilizer. Because the transponder chip is embedded in the key/fob, it can be costly to replace. If you lose a key or fob, your Toyota dealer can help. Alternatively, you can find a qualified independent locksmith to perform high-security key services by consulting your local Yellow Pages or by contacting www.aloa.org. **45.** Fueling time varies with hydrogen fueling pressure and ambient temperature. **46.** Cargo and load capacity limited by weight and distribution. **47.** 2019 EPA-estimated 67 city/67 highway/67 combined MPGe for Mirai and 312-mile driving range. Actual mileage will vary. Range measurement pursuant to SAE J2601 standards (ambient temperature: 20°C; hydrogen tank pressure when fueled: 70 MPa). Fueling time varies with hydrogen fueling pressure and ambient temperature. **48.** TMS U.S.A. is not responsible for operability of stations or their progress in construction. Projected operational dates are estimates and subject to change as a result of permit application/approval process, construction process and station certification process. **49.** Projected hydrogen station operational dates are TMS U.S.A.'s best estimates for when stations will be available for use by Mirai customers according to representation of construction progress by California Governor's Office of Business and Economic Development (Go-Biz). Operational date estimates are based on construction start date. **50.** Standard ToyotaCare covers normal factory scheduled maintenance for two years or 25,000 miles, whichever comes first and also includes 24-hour roadside assistance for two years, regardless of mileage. The Mirai enhancement of ToyotaCare — a total of 3 years or 35,000 miles, whichever comes first — is valid only at authorized Mirai Fuel Cell Electric Vehicle Dealership in the continental United States. See an Authorized Mirai Fuel Cell Electric Vehicle Dealership for details and exclusions. **51.** The twenty-one complimentary days will expire after the third year and any unused days will not carry over. **52.** Complimentary fuel for three years or \$15,000 maximum, whichever comes first. The three-year period starts on the date of card activation or 90 days after vehicle sale or lease commencement date, whichever is earlier. Fuel card is nontransferable. The Mirai is a hydrogen-powered fuel cell electric vehicle that must be fueled at hydrogen stations conforming to the latest Society of Automotive Engineers (SAE) hydrogen fueling interface protocol standards or laws that may supersede such SAE standards. Refer to the Mirai Hydrogen Stations Locator App in Entune™, www.toyota.com, or call Toyota customer service at 1-800-331-4331 for information on hydrogen fueling stations available to Mirai. **53.** Extra-cost color.

WARRANTIES

Every Toyota Car, Truck and SUV is built to exceptional standards. And that's not idle boasting. We back it up with these Limited Warranty Coverages:

Basic: 36 months/36,000 miles (all components other than normal wear and maintenance items).

Fuel-Cell-System-Related Component Coverage: Fuel Cell System components, including the FC Battery Pack, Battery ECU, FC Air Compressor, FC Boost Converter, FC ECU, H2 tanks, FC PCU (Power Control Unit), FC system, HF ECU (H2 Fueling ECU), and Power Management ECU (HV ECU).

Powertrain: 60 months/60,000 miles (engine, transmission/transaxle, drive system, seatbelts and airbags).

Rust-Through: 60 months/unlimited miles (corrosion perforation of sheet metal).

Emissions: Coverages vary under Federal and California regulations. Refer to applicable *Warranty and Maintenance Guide* for details.

Some vehicles are shown with available equipment. Seatbelts should be worn at all times. For details on vehicle specifications, standard features and available equipment in your area, contact your Toyota dealer. A vehicle with particular equipment may not be available at the dealership. Ask your Toyota dealer to help locate a specifically equipped vehicle.

Accessories: For Genuine Toyota Accessories purchased at the time of the new vehicle purchase, the Toyota Accessory Warranty coverage is in effect for 36 months/36,000 miles from the vehicle's in-service date, which is the same coverage as the Toyota New Vehicle Limited Warranty.

For Genuine Toyota Accessories purchased after the new vehicle purchase the coverage is 12 months, regardless of mileage, from the date the accessory was installed on the vehicle, or the remainder of any applicable new vehicle warranty, whichever provides greater coverage.

You may be eligible for transportation assistance if it's necessary that your vehicle be kept overnight for repairs covered under warranty. Please see your authorized Toyota dealership for further details.

For complete details about Toyota's warranties, please visit www.toyota.com, refer to the applicable *Warranty and Maintenance Guide* or see your Toyota dealer.

All information presented herein is based on data available at the time of posting, is subject to change without notice and pertains specifically to mainland U.S.A. vehicles only. Prototypes shown. Actual production vehicles may vary.



Toyota drivers love to embrace new things and find new adventures. They just can't sit still. And proper vehicle maintenance is key to helping keep your Toyota safe, dependable and ready to explore. That's why we include a no cost maintenance plan with the purchase or lease of every new Mirai for 3 years or 35,000 miles, whichever comes first. 24-hour roadside assistance is also included for 2 years and unlimited miles. For all the details and exclusions, please call, visit online or stop by your local Toyota dealer today. Valid only in the continental U.S. and Alaska. Let's drive with confidence. Welcome to the ToyotaCare advantage.



For Toyota Mobility program details, go to www.toyota.com/mobility or call the Toyota Customer Assistance Center at 1-800-331-4331